

APPLICATION NOTE 430

## Voltage Reference Compensates Reference Junction

*Abstract: This application note discusses how to use a precision voltage reference with a junction temperature pin (MAX873) to bias up the reference junction of various thermocouple types.*

A voltage-reference IC with TEMP output (see the figure below) offers just the capabilities needed to compensate the reference junction of common thermocouples.

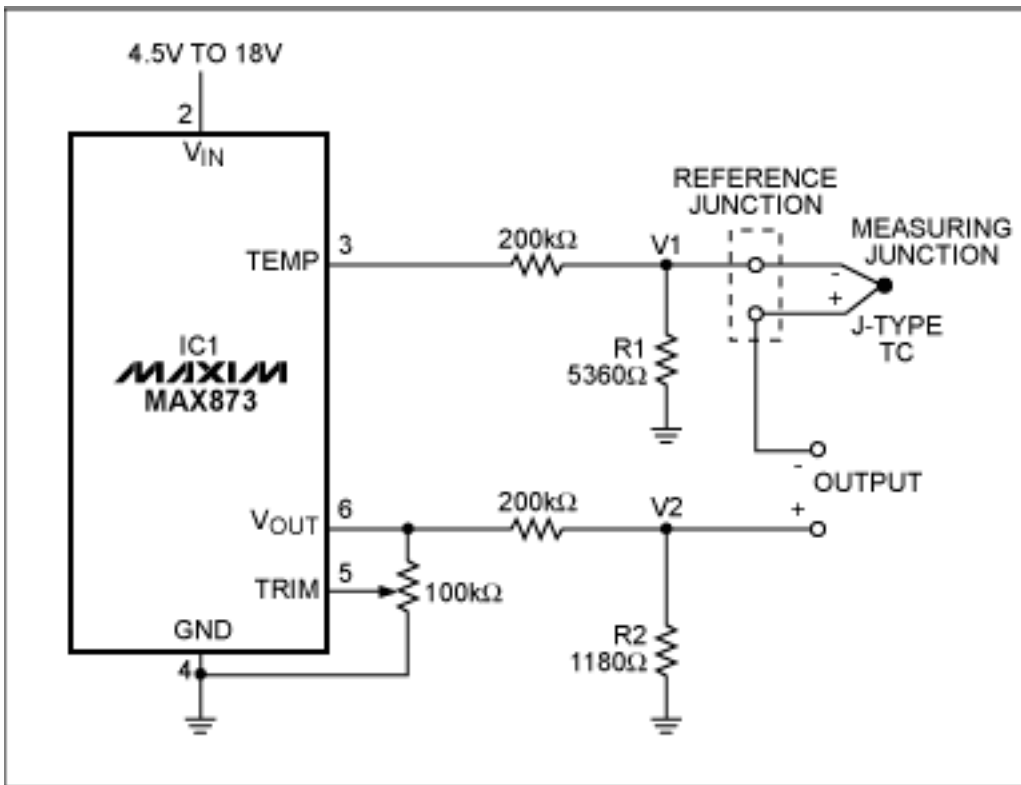

*Using voltages generated at TEMP and VOUT by the voltage-reference IC, this circuit compensates the reference junction of a thermocouple.*

A thermocouple is the junction of two dissimilar metals. It produces a small voltage (the Seebeck coefficient) that varies predictably with temperature:

Thermocouple Type (ANSI Designation)	Seebeck Coefficient
J (iron-constantan)	52.3 $\mu$ V/ $^{\circ}$ C
T (copper-constantan)	42.8 $\mu$ V/ $^{\circ}$ C
K (chromel-alumel)	40.8 $\mu$ V/ $^{\circ}$ C
S (platinum-{ 10% rhodium in platinum})	6.4 $\mu$ V/ $^{\circ}$ C

In practical setups, the voltmeter connections form a second thermocouple (the reference junction), and the measured voltage represents the *difference* in temperature between this reference and the thermocouple itself

(the measuring junction). Thus, you must either maintain the reference junction at a known temperature, such as that of an ice bath, or apply a compensating voltage that makes the reference appear to be at 0°C regardless of its actual temperature. An ice-bath stabilization produces the desired 0V output at 0°C, but that approach is impractical for most applications.

IC1's reference output (VOUT) equals 2.5V, and its TEMP output is proportional to temperature, measuring 608mV at 25°C with a temperature coefficient (TCV<sub>TEMP</sub>) of 2mV/°C. You should adjust R1 so that V1 equals the thermocouple's Seebeck coefficient and R2 so that V2 equals the V1 output at 0°C. (For J-type thermocouples, R1 = 5360Ω and R2 = 1180Ω.)

For proper operation, the IC should be in thermal contact with the reference junction and all resistors should have temperature coefficients of ±5ppm/°C or better. To calibrate the system, adjust the potentiometer so that (V1 - V2) equals the thermocouple output voltage at the known ambient temperature.

---

Application Note 430: <http://www.maxim-ic.com/an430>

### More Information

For technical questions and support: <http://www.maxim-ic.com/support>

For samples: <http://www.maxim-ic.com/samples>

Other questions and comments: <http://www.maxim-ic.com/contact>

### Related Parts

MAX873: [QuickView](#) -- [Full \(PDF\) Data Sheet](#) -- [Free Samples](#)

AN430, AN 430, APP430, Appnote430, Appnote 430

Copyright © by Maxim Integrated Products

Additional legal notices: <http://www.maxim-ic.com/legal>