

APPLICATION NOTE 4279

MAX2769 GPS Reference Design

Abstract: This reference design is a complete RF front-end solution for a GPS receiver using Maxim's MAX2769 GPS receiver chip. The MAX2769 is a low cost, single conversion, low IF GPS receiver that offers two integrated LNAs with different specifications, I/Q channel filters with variable bandwidth and order, and a digital IF output that supports 1-bit and 2-bit operation. This reference design offers high performance, small size, and low BOM cost.

More Information

- [Wireless Home](#)
- [Application Notes and Tutorials](#)
- [EV Kit Software](#)
- [Technical Support](#)

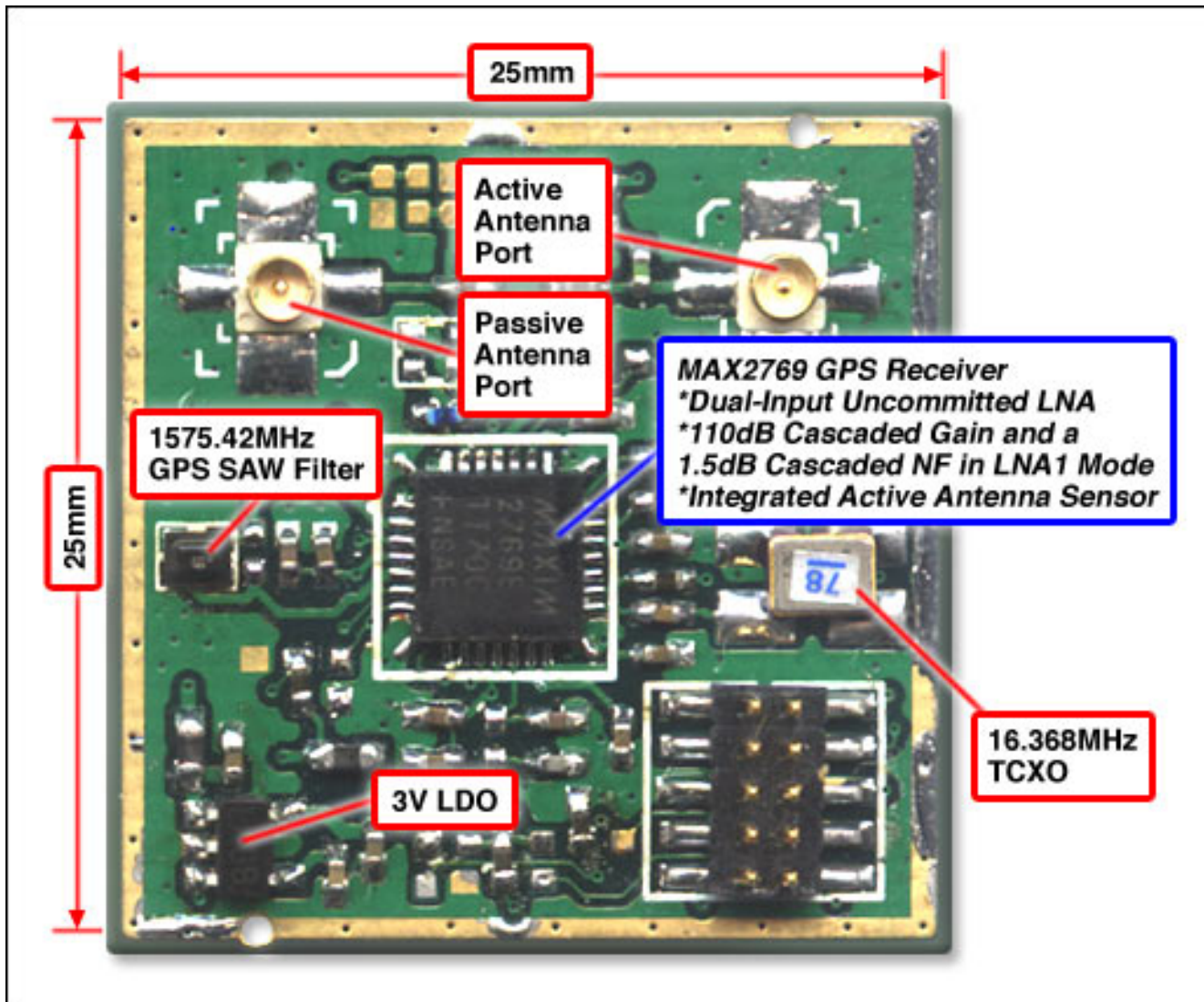

Figure 1. GPS reference design features the [MAX2769](#).

Important Design Features

- Dual-Input Uncommitted LNA for Separate Passive and Active Antenna Inputs
- Integrated Active Antenna Sensor Which Can Autoswitch the Antenna Input
- The I and Q Channel-Select Filters Can Be Selected as Either Third or Fifth Order
- Provides 110dB Cascaded Gain and a 1.5dB Cascaded NF in LNA1 Mode
- The IF Output Is Adjustable in 63 Steps Between 0MHz and 12.5MHz
- Can Be Used in Preconfigured States that Do not Require Programming Through the 3-wire SPI™ Interface

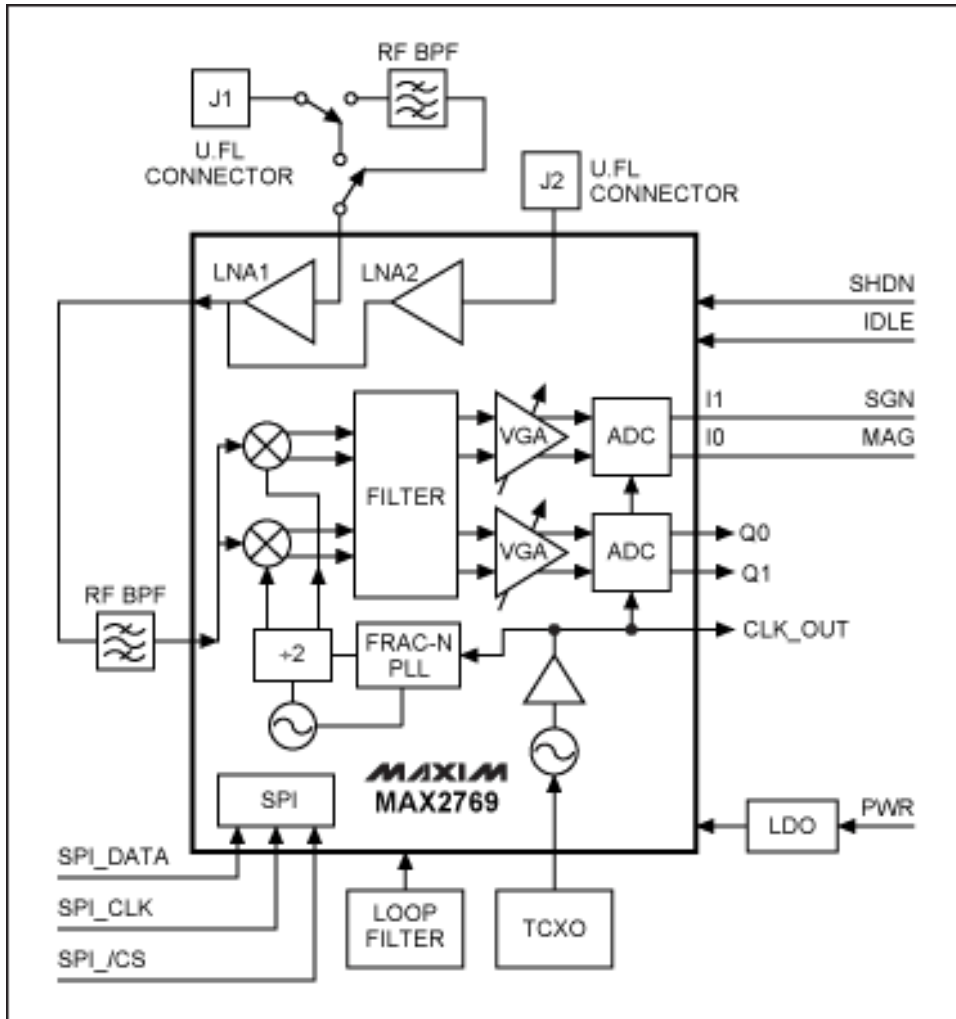

Figure 2. Block diagram for the GPS reference design.

Supply Current Summary

$V_{CC} = +3.0V$, $T_A = +25^{\circ}C$

Parameter	Test Conditions	Meas.	Unit
Operating Supply Current	Using LNA1 in default and low-current modes	18	mA

Receive Summary

Operating conditions: $V_{CC} = 3V$; $T_A = +25^{\circ}C$, Operating in default mode, PCB trace losses are included.

Parameter	Test Condition	Meas.	Unit
LNA1 Power Gain	Default and low-current modes	18.6	dB
LNA1 Noise Figure	Default and low-current modes	1.05	dB
LNA1 Third-Order Input Intercept Point	Default and low-current modes; LNA input to output. $P_1 = P_2 = -30dBm$; $f_1 = 1575MHz$, $f_2 = 1576MHz$	-1	dBm
LNA2 Power Gain	Default mode	12.9	dB
LNA2 Noise Figure	Default mode	1.35	dB
LNA2 Third-Order Input Intercept Point	Default mode	-2	dBm
Overall System NF	Using LNA1; PGA gain is maximum (CONF3 [27:22] is 111111)	1.6	dB
	Using LNA2; PGA gain is maximum (CONF3 [27:22] is 111111)	3.1	
IF Out Freq/Gain Range Through System Using LNA1	1575.42MHz in, 4.092MHz out; analog output mode	59 -117	dB
4MHz Offset Rejection	1579.42MHz in, third-order BPF; PGA gain is maximum (CONF3[27:22] is 111111)	32	dB
	1579.42MHz in, fifth-order BPF; PGA gain is maximum (CONF3[27:22] is 111111)	51	
IF Passband 3dB Bandwidth	IF filter center bandwidth 2.6MHz; set bit 4:3 of CONF1 register to 00	2.9	MHz

Operating Characteristics

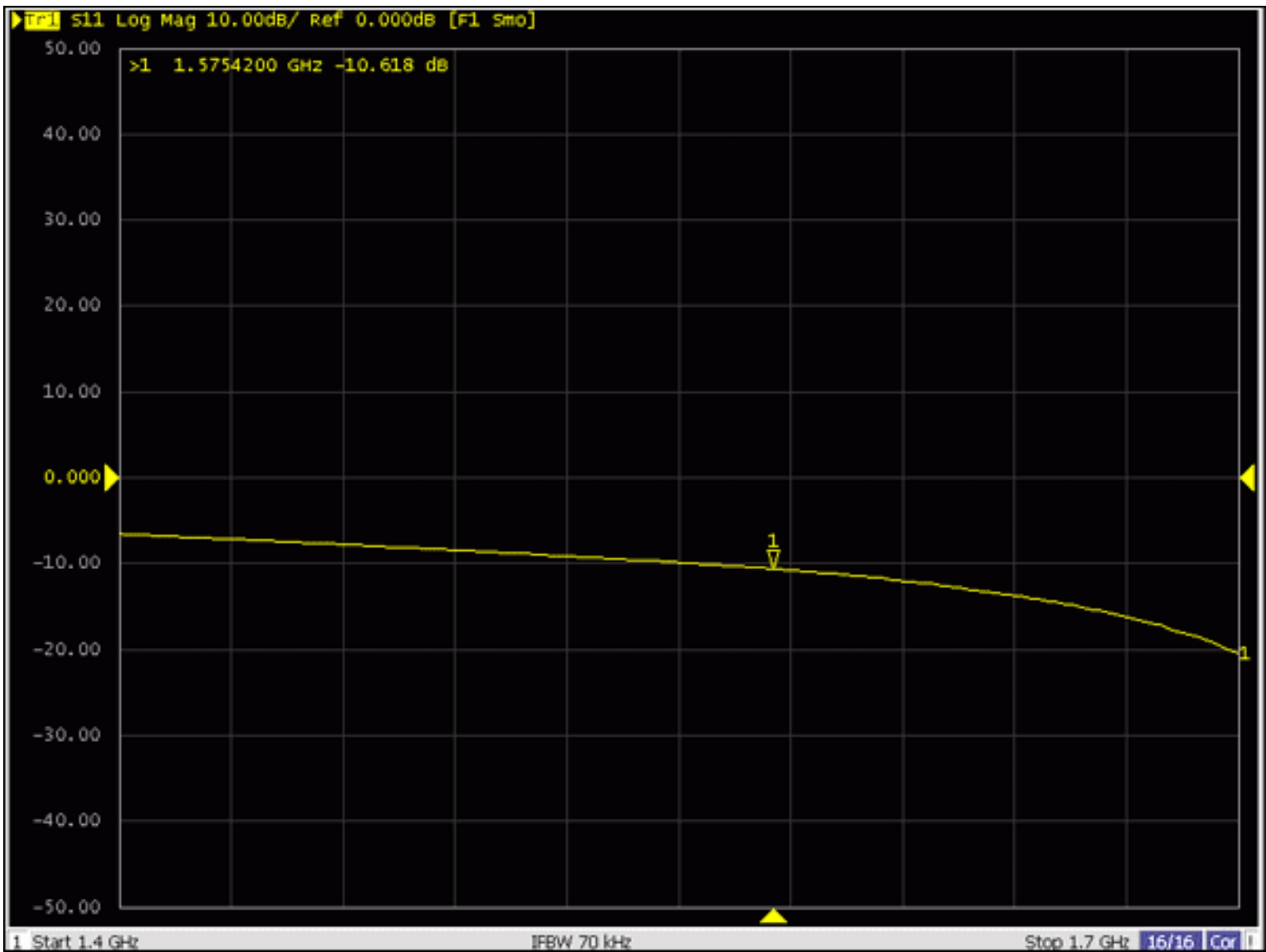

Figure 3. Input S11 of the MAX2769 LNA1. Measured by network analyzer at 1575.42MHz. The S11 is -10.4dB.

Detailed Description

This reference design is a low-cost, single-conversion, low-IF GPS receiver. The design offers more flexibility and performance than its predecessors for a wide range of GPS applications such as mobile handsets, PDA's, embedded PCs, and automotive applications.

SPI is a trademark of Motorola, Inc.

Application note 4279: www.maxim-ic.com/an4279

More Information

For technical support: www.maxim-ic.com/support

For samples: www.maxim-ic.com/samples

Other questions and comments: www.maxim-ic.com/contact

Automatic Updates

Would you like to be automatically notified when new application notes are published in your areas of interest? [Sign up for EE-Mail™](#).

Related Parts

MAX2769: [QuickView](#)

AN4279, AN 4279, APP4279, Appnote4279, Appnote 4279

Copyright © by Maxim Integrated Products

Additional legal notices: www.maxim-ic.com/legal