

APPLICATION NOTE 4275

GPS USB Reference Design with the MAX2769

Abstract: The MAX2769 is a low-cost, single-conversion, low-IF frequency GPS receiver that provides 115dB cascaded gain and a 1.4dB cascaded NF. The MAX2769 GPS USB reference design, working together with the GeotateSM GPS software installed in a PC or laptop, forms a complete low-cost high-sensitivity GPS solution. The reference design provides high-precision position information with quick acquisition times. It demonstrates the excellent capabilities of the MAX2769 in a full GPS receiver design.

More Information

- [Wireless Home](#)
- [Application Notes and Tutorials](#)
- [EV Kit Software](#)
- [Technical Support](#)

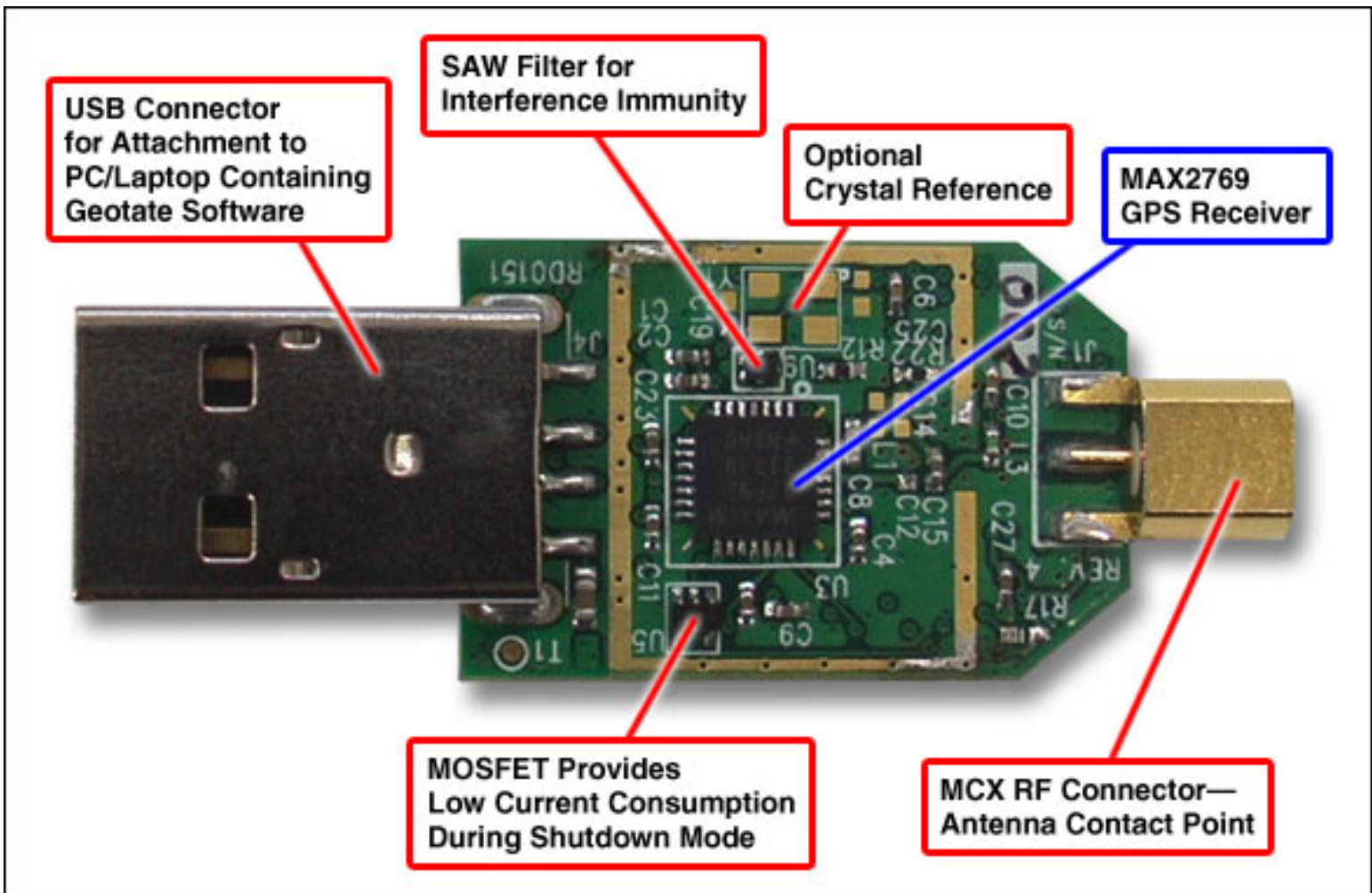

Figure 1. Top view of the GPS reference design that features the [MAX2769](#) universal GPS receiver.

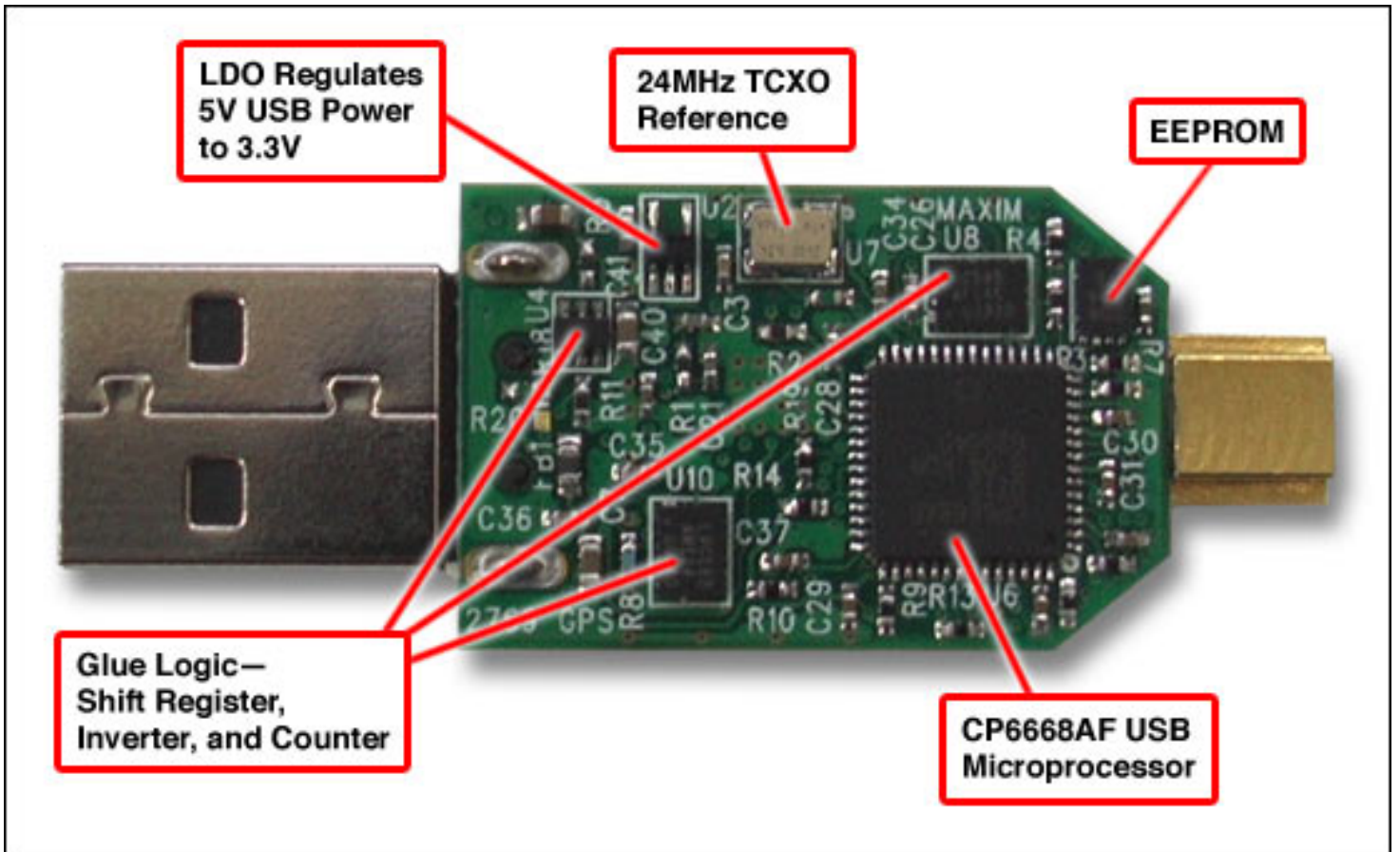

Figure 2. Bottom view of the design board.

Important Design Features

- Complete USB Solution When Paired with Geotate Software
- MAX2769 Offers 1.4dB Cascaded Noise Figure, and 115dB Gain with 60dB AGC Range
- Receiver/Software Combination Provides -139dBm Acquisition Sensitivity and -152dBm Tracking Sensitivity
- Choice of Two LNAs for Use with Active or Passive Antenna
- Choice of Single or Dual Frequency References
- Fractional-N Synthesizer and Wide Range of IF Filters for Maximum Flexibility
- SAW Filter for Noise Immunity

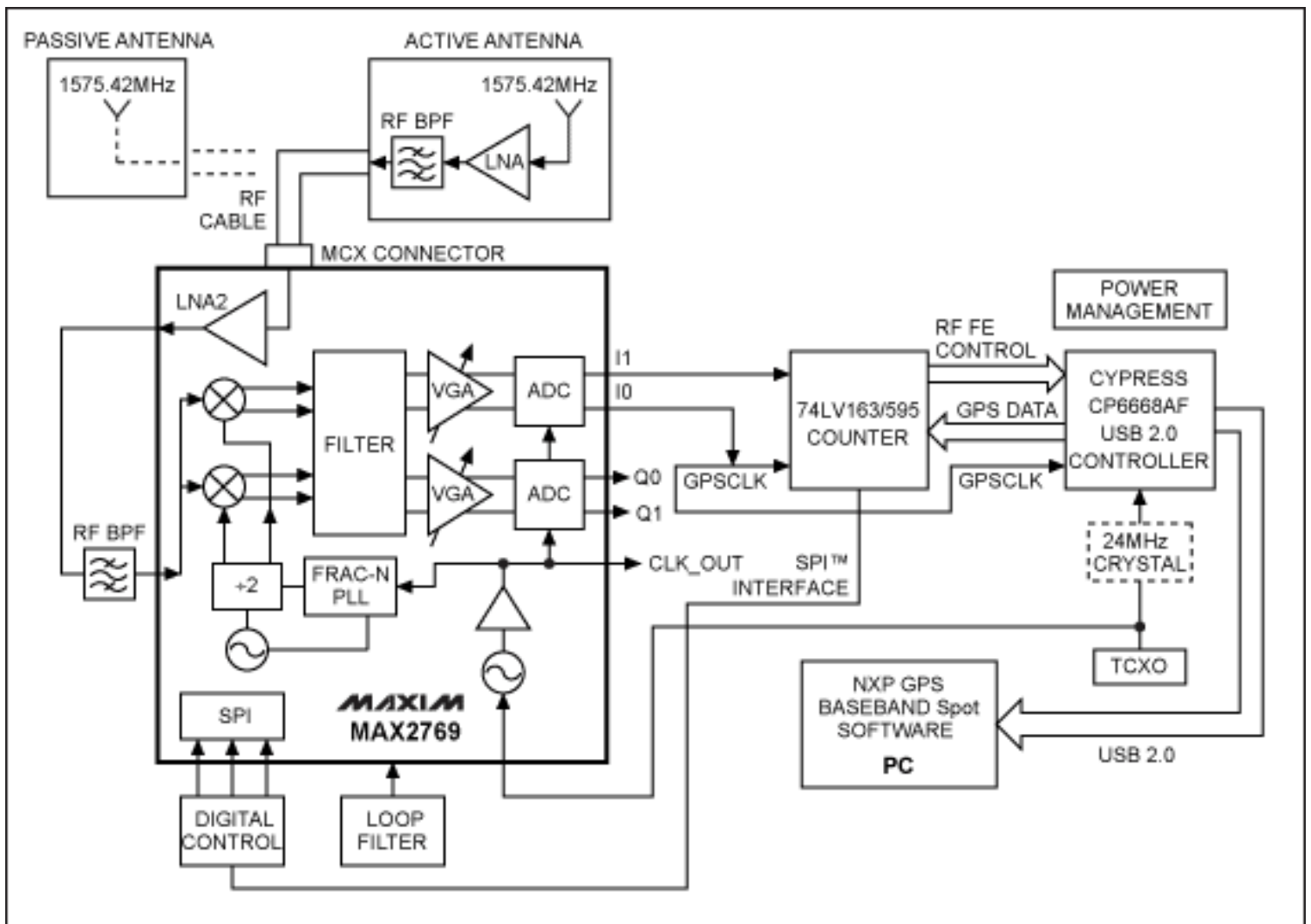

Figure 3. Block diagram of the GPS USB reference design.

Lab Measurements

DC Characteristics

$V_{USB} = +5V$, $V_{CC} = +3.3V$, $T_A = +25^\circ C$

Parameter	Test Condition	Meas.	Unit
Continuous Current	Unit tracking satellites	64	mA
Shutdown Current	Separate crystal reference for digital circuitry	0.5	mA
	Single TCXO reference	2.5	

RF Performance

$V_{USB} = +5V$, $V_{CC} = +3.3V$, $f_{RF} = 1575.42MHz$, $T_A = +25^\circ C$

Parameter	Test Condition	Meas.	Unit
Acquisition Sensitivity ¹	< 150 second average time to first fix under cold-start condition (almanac but no satellite position information)	-139	dBm
Tracking Sensitivity ¹	Maintains intermittent track for > 1 minute	-152	dBm
Average Acquisition Time	Cold start ²	30	sec
	Warm start ²	5	
	Hot start ²	2	
Position Accuracy	Horizontal	3	m
	Vertical	6	

¹LNA1 with passive antenna, or LNA2 with active antenna having 1.5dB noise figure and > 20dB gain.

²Power in = -130dBm; cold start: almanac but no satellite information; warm start: almanac and recent satellite position information; hot start: restart after instantaneous loss of signal.

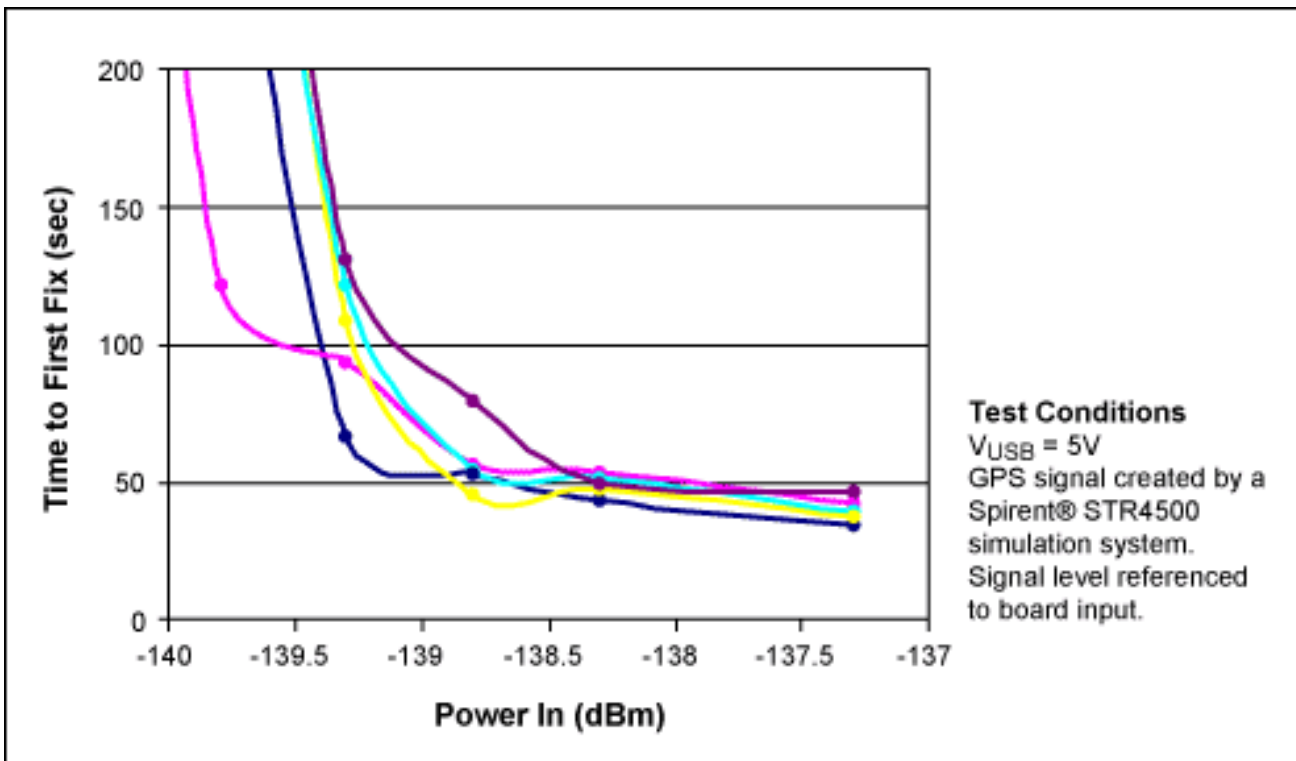

Figure 4. Data shows time to first fix under cold-start conditions. At high levels, the average fix time is 30 seconds. At 2dB above sensitivity level, the fix time is around 50 seconds. The sensitivity level is defined as that incident power where fix time exceeds 150 seconds.

Detailed Description

The MAX2769 offers a choice of two different integrated LNAs. LNA1 has a higher gain and a lower noise figure for use with a passive antenna; LNA2 offers a higher IP3 and lower power consumption at the expense of a slightly lower gain and higher noise figure. LNA2 is for use with active external antennas. The pin-out allows for an external GPS-band filter between the LNA output and the mixer input. Both the reference and IF frequencies are variable and can match a broad variety of frequency plans. The I and Q channel-select filters cover a wide range of bandwidths, and can be selected as either third or fifth order. In this way, the baseband processor can adjust (or fix) the desired channel bandwidth for best sensitivity. An on-chip fractional-N synthesizer, tuned with the help of an external loop filter, provides high-IF selectivity with low phase noise. The IF output is adjustable in 63 steps

between 0MHz and 12.5MHz. The integrated ADCs can be set to 1-, 2-, or 3-bit resolution.

This reference design utilizes 1-bit data and downconverts the L1 band 1575.42GHz GPS (or Galileo) signal to a 1.57MHz IF. A USB microprocessor and glue logic provide a full USB interface with a PC or laptop. The design operates with Geotate's "Spot" software installed on the PC's CPU. While the design is delivered with a single TCXO reference of 24MHz, it can operate with separate references for the digital and RF portions, thus permitting the use of a different RF reference, if desired. Customers could select between the two LNAs with a change of software version and the replacement of one capacitor on the board. A SAW filter is included after the LNA for noise immunity. The system could also be retuned for GLONASS operation by replacing the SAW filter and changing a software version. The SPI information required to set up the IC is delivered over the USB lines and converted in the microprocessor to the 3-signal format that the IC requires. PID/VID information, along with the necessary information to program the settings upon startup, is loaded through an EEPROM on the board.

Glue logic is used both to convert the serial data output from the IC to parallel format for the microprocessor, and to adjust clock timing. The microprocessor then converts the information to DP and DM signals for transmission over the USB cable to the PC processor. At that point the Spot software converts the signals into latitude, longitude, and altitude information. Spot software enables the user to observe satellite and signal-strength information, almanac information, time to first fix, and position information.

Application Note Links

Application note 3910, "[A User Guide for the MAX2769 GPS Receiver.](#)"

Geotate is a service mark of Geotate B.V. Company, Netherlands.

SPI is a trademark of Motorola, Inc.

Spirent is a registered trademark of Spirent Communications PLC, United Kingdom.

Application note 4275: www.maxim-ic.com/an4275

More Information

For technical support: www.maxim-ic.com/support

For samples: www.maxim-ic.com/samples

Other questions and comments: www.maxim-ic.com/contact

Automatic Updates

Would you like to be automatically notified when new application notes are published in your areas of interest?

[Sign up for EE-Mail™.](#)

Related Parts

MAX2769: [QuickView](#)

AN4275, AN 4275, APP4275, Appnote4275, Appnote 4275

Copyright © by Maxim Integrated Products

Additional legal notices: www.maxim-ic.com/legal