

APPLICATION NOTE 4274

WiBro Reference Design with the MAX2837

Abstract: The WiBro™ reference design is a complete RF front-end solution designed to meet requirements for the WiBro 2.3GHz to 2.4GHz mobile WMAN (Wireless Metropolitan Area Network) standard. This reference design uses the MAX2837 direct-conversion transceiver and demonstrates a complete WiBro single-band RF-to-baseband solution. It serves as a platform for designs in multiple form factors such as CardBus, miniPCI, and custom CPE modules. The design can be easily adapted for WiBro-only 3.3V laptop applications, or WiBro-only 5.0V CPE applications.

- More Information
- [Wireless Home](#)
 - [Application Notes and Tutorials](#)
 - [EV Kit Software](#)
 - [Technical Support](#)

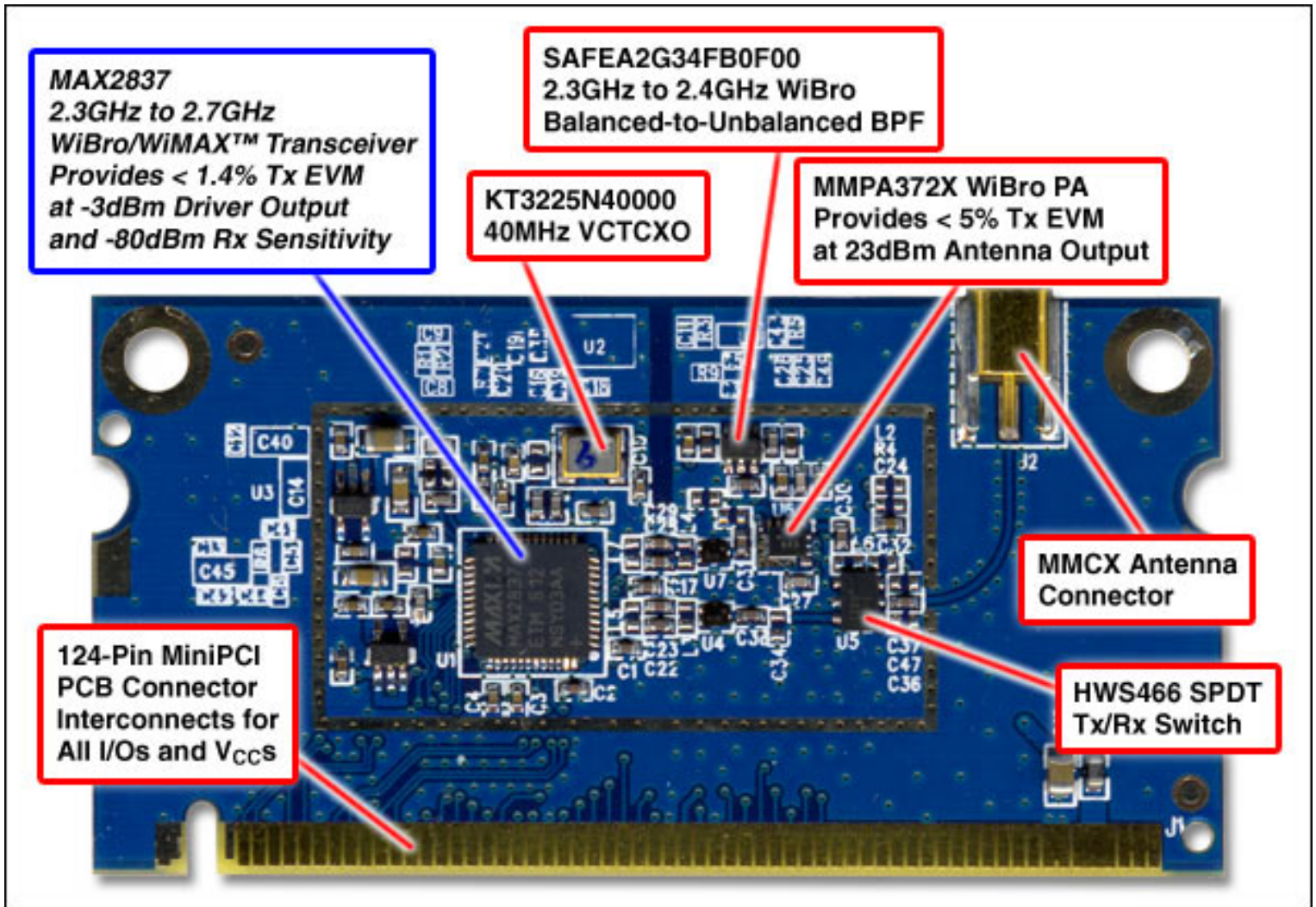
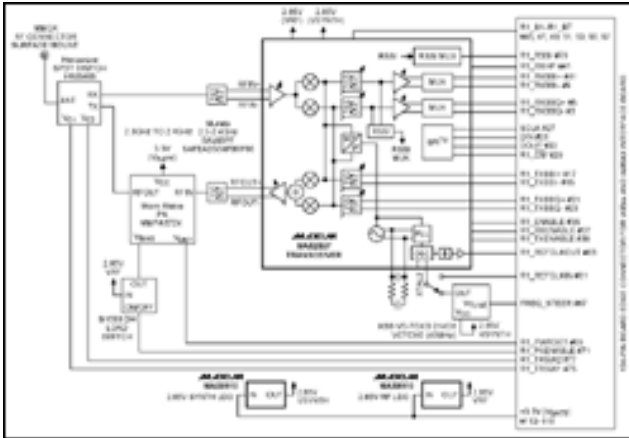

Figure 1. The WiBro reference design features the [MAX2837](#) direct-conversion transceiver.

Important Design Features

- Complete RF-to-Baseband WiBro Solution
- +23dBm Transmit Power at 5% EVM and Meets Spectral Mask Requirements
- -79dBm Receive Sensitivity at 10% EVM
- 60dB of Transmit Gain-Control Range
- 94dB of Receive Gain-Control Range
- Optimized Low-Current Modes



[More detailed image](#) (PDF, 324kB)

Figure 2. Block diagram for the WiBro reference design.

Lab Measurements

Supply Current Summary

$V_{BATT} = +3.6V$, $V_{CC} = +2.85V$, $T_A = +25^\circ C$

Parameter	Test Conditions	Measured	Units
Shutdown Supply Current	MAX2837 and PA in shutdown; regulators and VCTCXO still active	1.8	mA
Idle Supply Current	MAX2837 in idle mode; PA in shutdown; regulators and VCTCXO active	34.8	mA
Transmit Supply Current	16 QAM, $\frac{3}{4}$ FEC coding rate, $P_{OUT} = +24dBm$, EVM = 5%	392.6	mA
Receive Supply Current In	Low-current mode	79	mA
	Nominal current mode	96.2	

Receive Summary

$V_{BATT} = +3.6V$, $V_{CC} = +2.85V$, $f_{RF} = 2347MHz$, $V_{OUT} = 90mV_{RMS}$, WiBro signal, RF specs are antenna referred, $T_A = +25^{\circ}C$

Parameter	Test Conditions	Measured	Units
DC Offset	I channels	6.8	mV
	Q channels	4.5	
VGA Gain Step Size		2	dB
Receive Gain-Control Range	Max to min VGA gain	61.7	dB
Receive LNA Gain Step	Attenuation from 0dB to -16dB	-15.9	dB
	Attenuation from 0dB to -32dB	32.1	
Gain Variation over Temperature	$T_A = -40^{\circ}C$ to $+85^{\circ}C$	LNA gain = 0dB	-5.2
		LNA gain = -16dB	-5.3
		LNA gain = -32dB	-3
Gain Variation over Frequency	$f_{LO} = 2304MHz$ to $f_{LO} = 2396MHz$	0.2	dB
Sensitivity at Low Supply Current ¹	64 QAM, $\frac{3}{4}$ FEC coding rate, 10% EVM at sensitivity	-79.8	dBm
	16 QAM, $\frac{3}{4}$ FEC coding rate, 20% EVM at sensitivity	-90.7	
Sensitivity at Nominal Supply Current ¹	64 QAM, $\frac{3}{4}$ FEC coding rate, 10% EVM at sensitivity	-80.4	dBm
	16 QAM, $\frac{3}{4}$ FEC coding rate, 20% EVM at sensitivity	-91.3	

¹Rx EVM limits are at BB I/Q Rx outputs, and are given in the IEEE® 802.16e specification Table 338, "Receiver SNR Assumptions." The assumption is that this EVM for this modulation rate is sufficient to meet 1e-6 BER.

Transmit Summary

$V_{BATT} = +3.6V$, $V_{CC} = +2.85V$, $f_{RF} = 2347MHz$, $V_{IN} = 90mV_{RMS}$, WiBro signal, RF specs are antenna referred, $T_A = +25^{\circ}C$

Parameter	Test Conditions	Measured	Units
LO Leakage	$Q = 640/352\mu A$, $I = 576/416\mu A$	-39.6	dBc
Sideband Suppression	I/Q phase = -0.5°	-52.5	dBc
Transmit Power-Control Range	Including PA gain step	64.5	dB
Gain Variation over Frequency	$f_{LO} = 2304MHz$ to $f_{LO} = 2396MHz$	1.9	dB
Transmit EVM	16 QAM, $\frac{3}{4}$ FEC coding rate, $P_{OUT} = +24dBm$, meeting spectral mask	4.1	%
	16 QAM, $\frac{3}{4}$ FEC coding rate, $P_{OUT} = +23dBm$, meeting spectral mask	3.5	

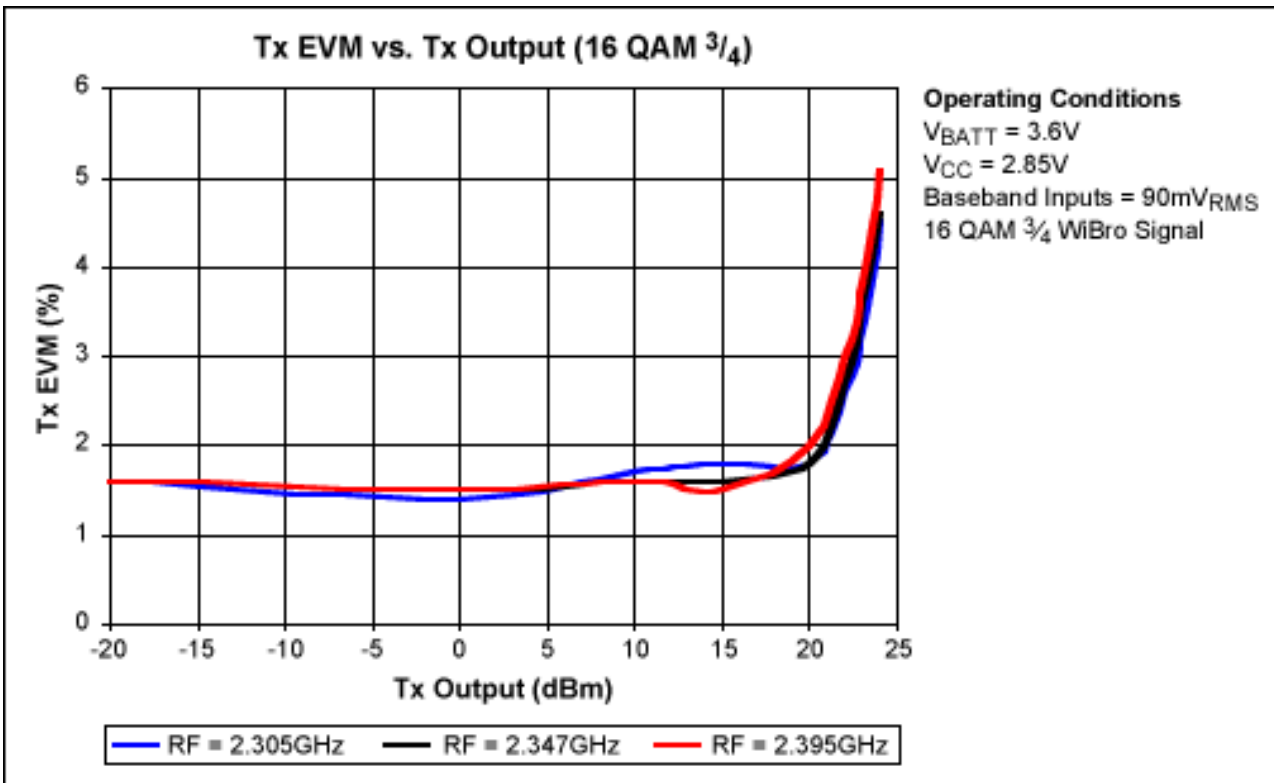

Figure 3. Output EVM for the reference design. The WiBro reference design delivers more than 23dBm of output power at the antenna, while meeting the required EVM specification of 5.5% over the entire 2.3GHz to 2.4GHz band.

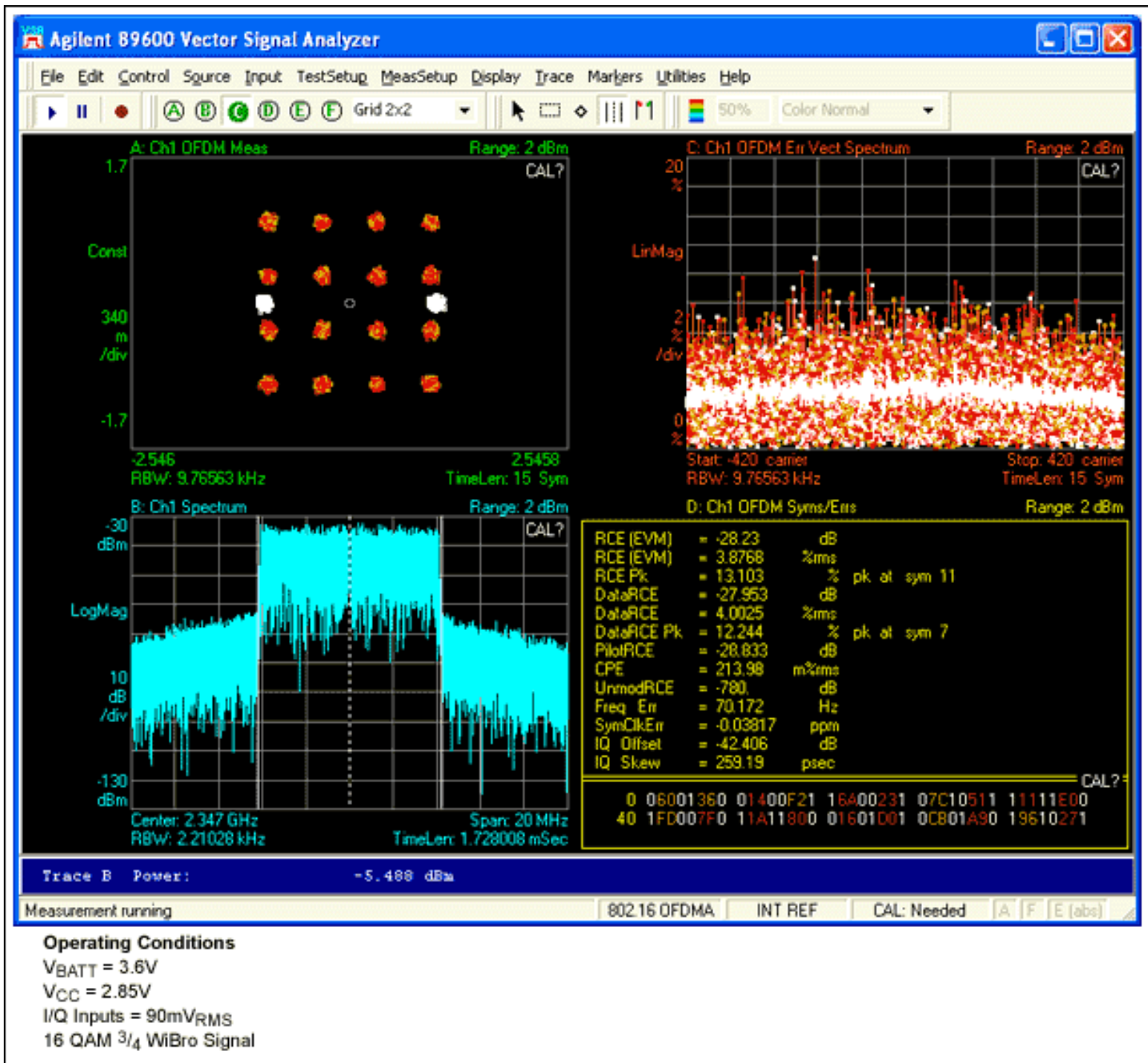

Figure 4. Transmit capture for the reference design. This capture shows the transmit spectrum, EVM constellation, and spectrum of the reference design at 23dBm of output power at the antenna. Measured EVM = 3.9% at 23dBm at 2.347GHz.

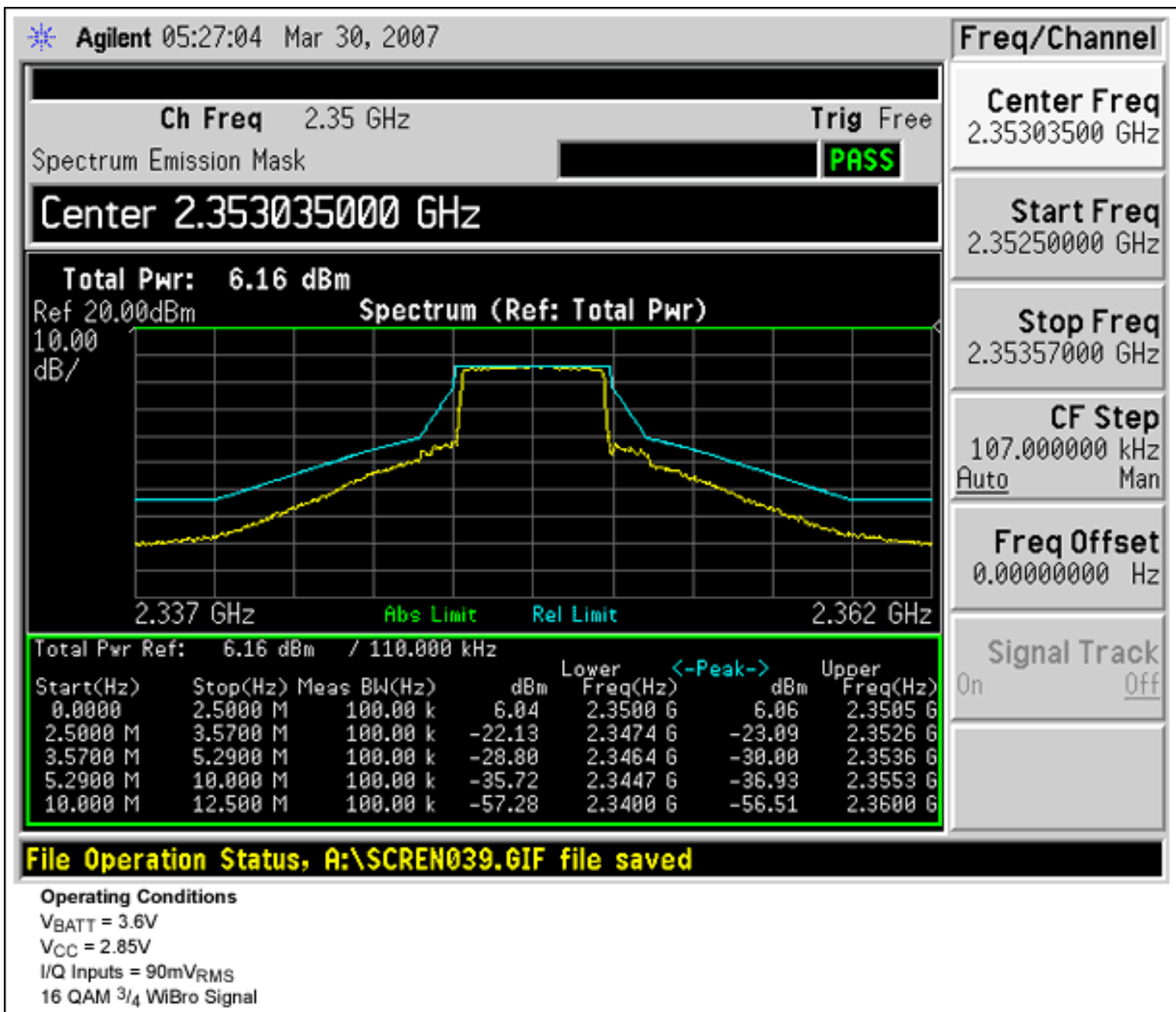

Figure 5. 2.35GHz, 10MHz spectral mask using ETSI-EN-301-021F mask. This capture shows that the WiBro reference design meets the ETSI-EN-301-021F spectral mask at 23dBm of output power at the antenna.

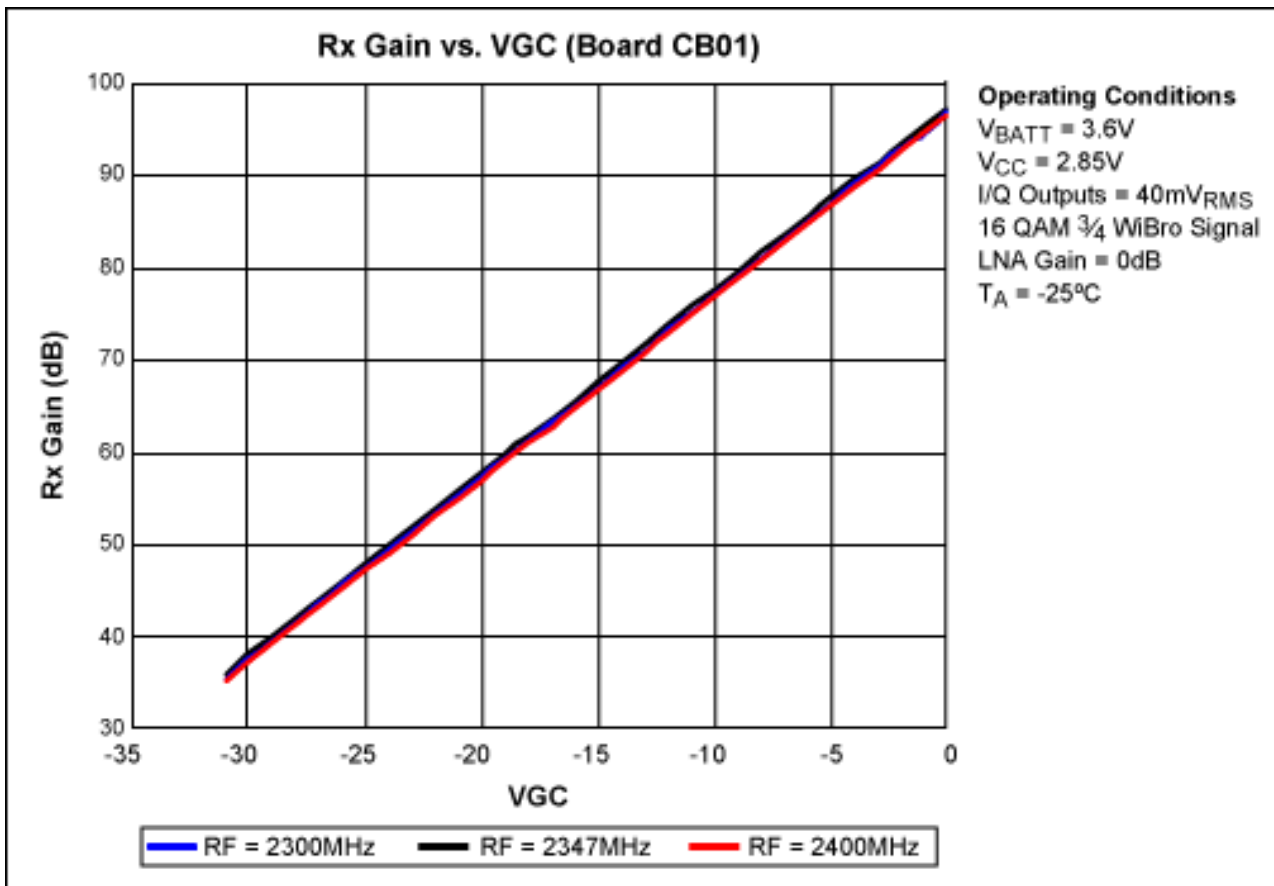

Figure 6. Receive gain characteristic across the 2.3GHz to 2.4GHz band. Gain variation over frequency is less than 0.2dB. Gain-control range, not including LNA gain steps, is 62dB, approximately 2dB per gain step.

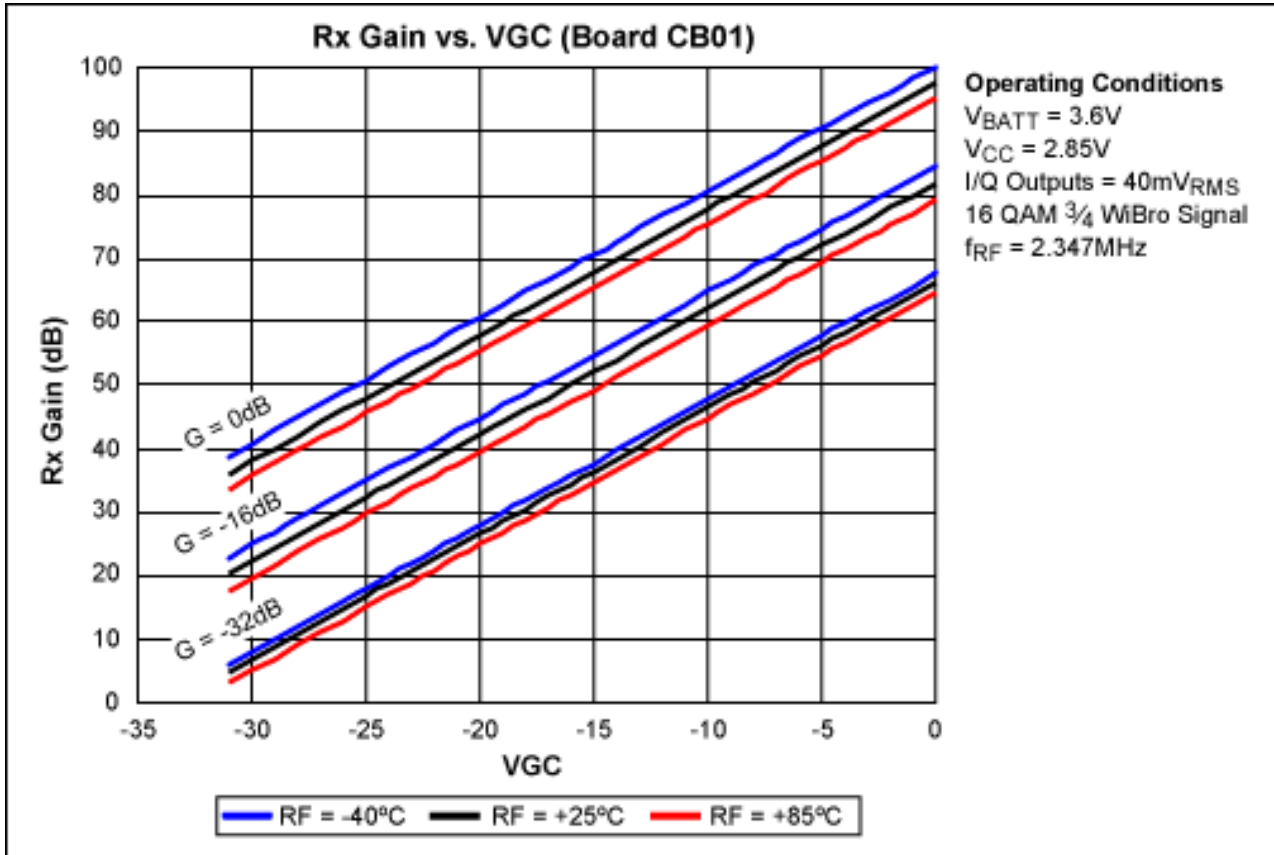

Figure 7. Gain characteristic across three LNA gain attenuations and temperatures. Gain variation over temperature for LNA attenuations 0dB and -16dB is approximately 5dB, and roughly 3dB for -32dB gain attenuation.

Detailed Description

The WiBro reference design includes the following components: MAX2837 direct-conversion transceiver, Micro Mobio MMPA372X PA, MAX8510 regulators, Murata balanced-to-unbalanced SAW bandpass filters, Hexawave HWS466 SPDT Tx/Rx switch, and Vishay Si1563DH load switch.

The MAX2837 is a single-chip, wideband, direct-conversion transceiver designed for 2.3GHz to 2.7GHz WiBro and WiMax radios. The transceiver is fully equipped with an on-chip broadband VCO, fast settling sigma delta RF synthesizer, crystal oscillator, programmable lowpass filters, proprietary DC offset cancellation, I/Q error and carrier leakage detection circuits. The MAX2837 offers less than 1.4% of transmit EVM at -3dBm driver output power, and receive sensitivity better than -79dBm. When integrated with the MMPA372X PA and Murata BPF, the reference design can deliver at least 23dBm of output power at the antenna, while meeting WiBro EVM and spectral-mask requirements with margin.

IEEE is a registered service mark of the Institute of Electrical and Electronics Engineers.

SPI is a trademark of Motorola, Inc.

WiBro is a trademark of the Telecommunications Technology Association, Republic of Korea.

WiMAX is a trademark of the WiMAX Forum.

Application note 4274: www.maxim-ic.com/an4274

More Information

For technical support: www.maxim-ic.com/support

For samples: www.maxim-ic.com/samples

Other questions and comments: www.maxim-ic.com/contact

Automatic Updates

Would you like to be automatically notified when new application notes are published in your areas of interest? [Sign up for EE-Mail™](#).

Related Parts

MAX2837: [QuickView](#)

AN4274, AN 4274, APP4274, Appnote4274, Appnote 4274

Copyright © by Maxim Integrated Products

Additional legal notices: www.maxim-ic.com/legal