

APPLICATION NOTE 4257

## Using the MAX4951 SATA Bidirectional Redriver to Drive eSATA Cable

By: Fred Zlotnick

*Abstract: With enhanced serial ATA (eSATA), the performance of a computer system with an external drive is virtually the same as that with an internal drive, and many times faster than USB 2.0. eSATA has separate receive/transmit paths at up to 3.0Gbps, whereas USB 2.0 is just a single 480Mbps link. With an eSATA port, a computer may easily have 1 terabyte (1TB) or more of external data that is as easy to access as an internal drive, but through up to 2m of cable. In order to accommodate the longer length cable, eSATA requires more drive than SATA. Therefore, the MAX4951 SATA bidirectional redriver was introduced to provide full eSATA drive requirements.*

### SATA and Previous Data-Transfer Protocols

Serial ATA (SATA) hard drives have nearly replaced parallel ATA (PATA) hard drives for laptop and desktop computers, and are used in some servers as well. The data portion of SATA cables/sockets contains only seven conductors (**Figure 1**) versus PATA's 40 data conductors. SATA cables are very flexible and do not require jumper settings. Internal SATA cables may be as long as 1m, while PATA cables are only 18in.

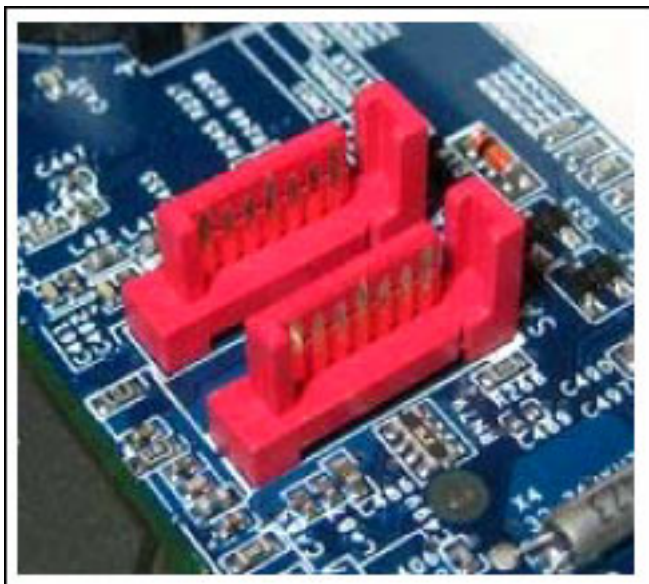

Figure 1. SATA connectors on a PC board.

The SATA I data transfer rate is 150MB/s for a serial data stream, while the maximum rate for parallel transfer is 133MB/s; SATA II can transfer at a rate of 300MB/s. Originally, SATA was simply intended to replace the awkward ribbon connector, and was only required to drive a 1m cable. However, a new standard called enhanced SATA (eSATA) was created to drive signals to a hard drive up to 2m outside the laptop/desktop computer. SATA/eSATA signals resemble standard LVDS, and are AC-coupled on a pair of 100 $\Omega$ -balanced transmission lines. Signal levels are nominally  $\pm 500\text{mV}_{\text{p-p}}$ . SATA at 1.5Gbps was a great success, and SATA/eSATA quickly progressed to 3.0Gbps, along with other improvements.

## eSATA

eSATA is a superset of SATA. A cable length of up to 2m is allowable, as eSATA is intended to be used for laptop/desktop computers with an external hard disk drive. Using eSATA, a computer may easily access 1 terabyte (1TB) or more of external data as quickly as with an internal drive. Because the cable length may be longer than SATA cables, eSATA cables require more signal drive than SATA. The eSATA connector is slightly different from the SATA connector, so that one cannot be interchanged for the other. **Figure 2** shows the cable ends of both SATA and eSATA. Both cable ends look similar, but the SATA cable end has a single notch.

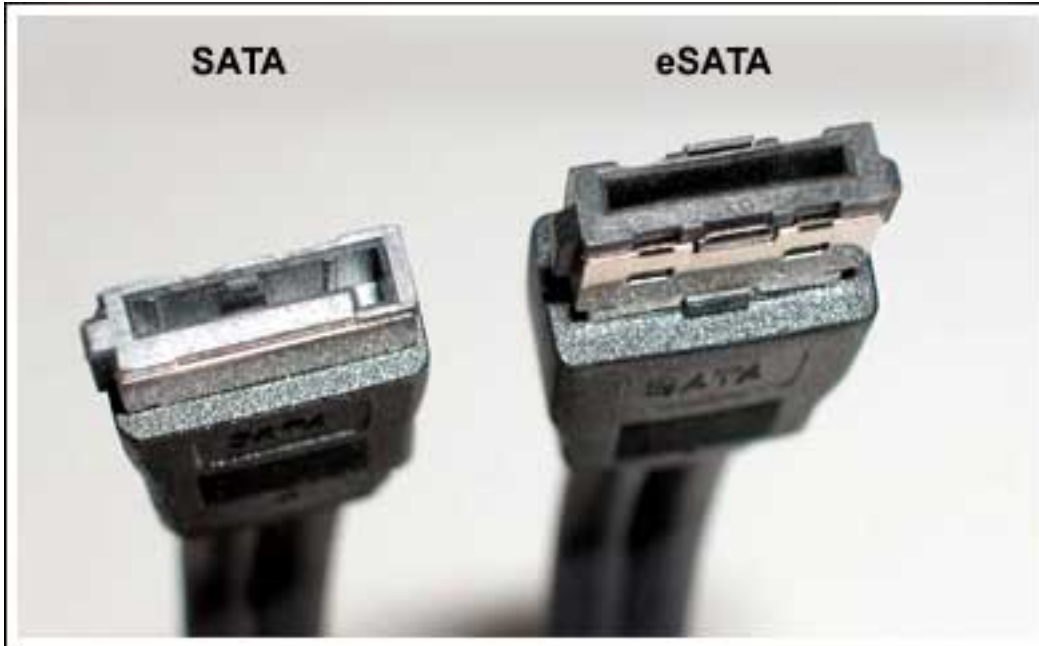

Figure 2. SATA and eSATA cable connectors.

With eSATA, the performance of the total system is virtually the same as with an internal drive, as eSATA has two data links and is many times faster than USB 2.0.

Designers are faced with a dilemma: they need to provide the very desirable eSATA port for their customers, but they must be certain that the SATA controller is placed on the motherboard where it is best for overall design. Because of the board constraints and the need to locate the eSATA connector where it is easily accessed, the designer may have to route the signal across the board. With the addition of losses from the connector, the signal may not meet eSATA signal level requirements.

## MAX4951 Fulfills eSATA Requirements

Fortunately, the MAX4951 SATA bidirectional redriver was introduced to accommodate the board/cable losses and provide full eSATA drive requirements. Optimal placement for the MAX4951 is close to the eSATA connector. The part is very small (only 4mm x 4mm), requires only a 3.3V supply, and can tolerate a 6dB loss at its input from the Northbridge and still easily provide enough output to drive the eSATA cable.

The MAX4951 contains two limiting differential amplifiers that have internal 50 $\Omega$  terminations at both the inputs and the outputs. The output level of each amplifier may be independently controlled by 2 bits that are usually set in the design phase of a board. If the board is driving eSATA, then bit 1 (B1) should be set high; if the MAX4951 is less than 6in (< 0.15m) then bit 0 (B0) may be left to float, and should be set high if the distance is  $\geq$  6in. For design purposes, the designer may wish to place a 1k $\Omega$  resistor from 3.3V to B0, and omit populating, if not needed.

## OOB Management

Out-of-band (OOB) signaling is handled explicitly in the MAX4951. OOB signals are the special, low-data-rate commands that the host and drive need for communication, or "hand-shaking." OOB signals are made up of a series of bursts at the 1.5Gbps data rate. These bursts may be thought of as a waveform (**Figure 3**) whose output goes through a switch. The switch permits many cycles of 1.5Gbps, and the host/drive communicate by decoding the period of these bursts. The MAX4951 contains a squelch circuit specifically to manage OOB signaling. Figure 3 shows what the burst might look like—there are a number of burst cycles, each followed by "dead" time.

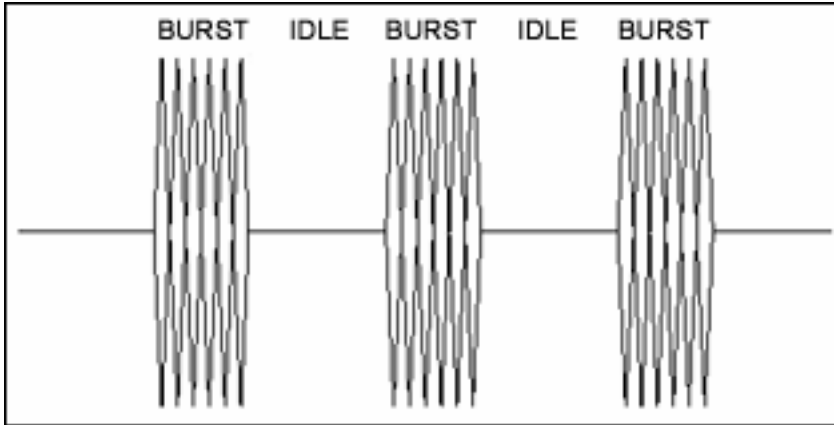

Figure 3. OOB signals.

For a redriver to behave properly in a SATA/eSATA environment, the device must reject or "squelch" any signal below 100mV. Without a squelch function, the redriver would amplify any noise in the system, and the OOB patterns would be lost. Using a MAX4951, the designer does not need to do anything specific to manage OOB signaling—the signals simply pass through the MAX4951, and any noise is squelched and prevented from interfering with the OOB signals.

## Receive Sensitivity Management

The designer should use rules that produce 100 $\Omega$ -balanced traces on the board—the layout software should permit this. The MAX4951 must be capacitor-coupled from both the host and drive side. Signal level at the input should be  $\geq 200\text{mV}_{\text{p-p}}$ . Output level can be set to either  $600\text{mV}_{\text{p-p}}$  or  $900\text{mV}_{\text{p-p}}$ .

**Figure 4** shows the eye pattern for the MAX4951 operating at 3.0Gbps with only  $200\text{mV}_{\text{p-p}}$  at its input. The output is selected by a user pin. The MAX4951 has signals from both directions, and the output level for each is easily selected by strapping a pin for each direction.

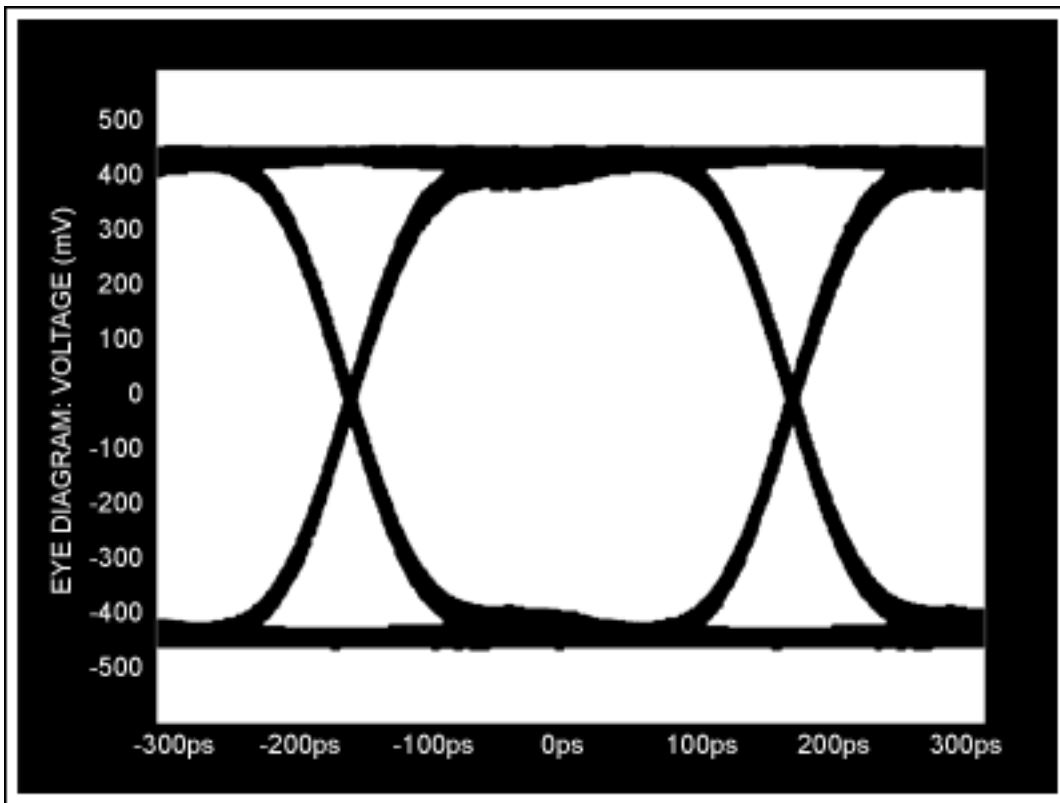

Figure 4. The MAX4951's eye pattern when operating at 3.0Gbps and an input of only 200mV<sub>p-p</sub>.

The output level shown is 900mV<sub>p-p</sub>, with only 200mV<sub>p-p</sub> at its input. The eye pattern would look nearly identical with SATA's 600mV<sub>p-p</sub> limit. Even with only 200mV<sub>p-p</sub> at the input, the output looks very clean.

## Design Example

The schematic in **Figure 5** shows the complete circuit for an eSATA redriver in a laptop or desktop application. This design boosts SATA to eSATA levels. The pins of the MAX4951 are laid out such that there is no need to cross over any leads. This design will be used as a basis for the MAX4951 evaluation kit (EV kit).

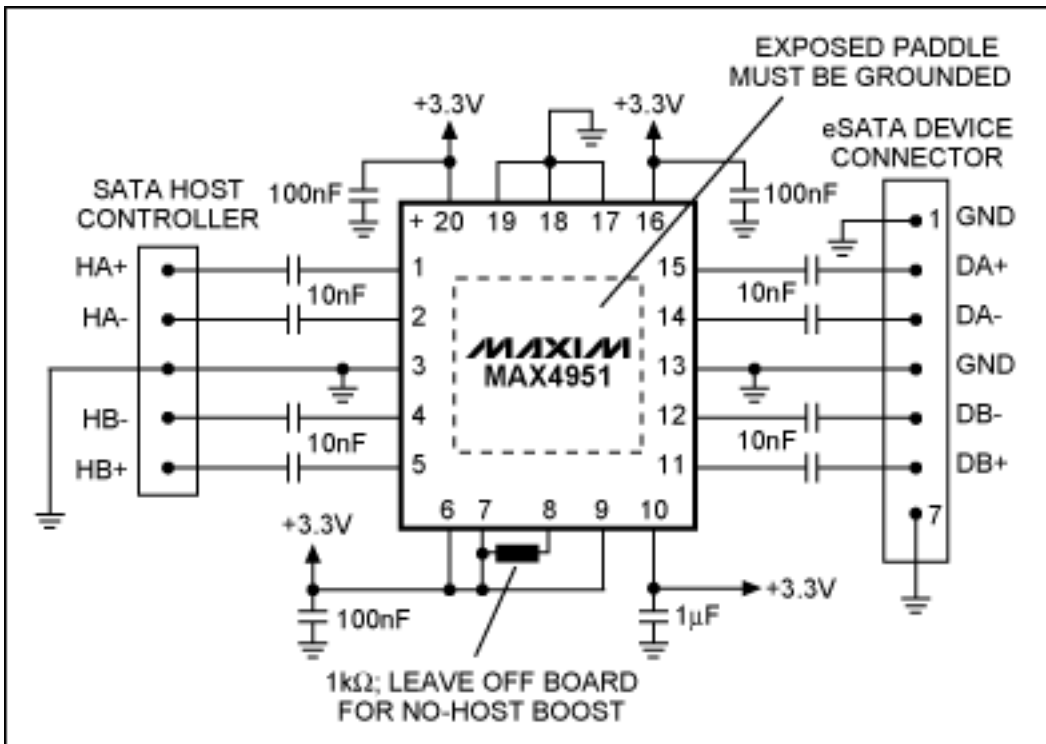

Figure 5. This laptop/desktop design incorporates the MAX4951 to boost SATA signals to eSATA levels.

## Conclusion

Many new laptop/desktop designs must accommodate eSATA devices. Because most designers do not have control of the Northbridge, they must accommodate signal losses on the board with some sort of active redriver. The MAX4951 redriver can accept minimum SATA output levels that are attenuated by 6dB or more and produce output signals that meet eSATA requirements. This redriver is laid out so that inputs and outputs simply flow with no crossovers, vias, or other layout tricks. The only added components are a few bypass and coupling capacitors. The MAX4951 terminates host transmission lines and full eSATA clean outputs to drive an external eSATA hard drive through up to 2m of cable.

Application note 4257: [www.maxim-ic.com/an4257](http://www.maxim-ic.com/an4257)

### More Information

For technical support: [www.maxim-ic.com/support](http://www.maxim-ic.com/support)

For samples: [www.maxim-ic.com/samples](http://www.maxim-ic.com/samples)

Other questions and comments: [www.maxim-ic.com/contact](http://www.maxim-ic.com/contact)

### Automatic Updates

Would you like to be automatically notified when new application notes are published in your areas of interest? [Sign up for EE-Mail™.](#)

### Related Parts

MAX4951: [QuickView](#) -- [Full \(PDF\) Data Sheet](#)

AN4257, AN 4257, APP4257, Appnote4257, Appnote 4257

Copyright © by Maxim Integrated Products

Additional legal notices: [www.maxim-ic.com/legal](http://www.maxim-ic.com/legal)