



APPLICATION NOTE 4235

Two Methods for Shutting Down a Current-Sense Amplifier

By: Arpit Mehta, Strategic Applications Engineer, and Prashanth Holenarsipur, Lead Product Definer

Abstract: This application note describes two techniques for shutting down a high-side current-sense amplifier. Both methods are well suited for managing power in next-generation, portable multimedia devices. They thus enable designers to extend battery life while still delivering an enriched user experience.

A similar version of this article was featured in [Maxim's Engineering Journal](#), vol. 63 (PDF, 1.3MB).

Overview

Unlike traditional operational amplifiers, high-side current-sense amplifiers do not include an internal electrostatic-discharge (ESD) protection diode between each input pin and the power-supply pin. As a result, they can operate at common-mode voltages well above the V_{CC} supply. Furthermore, pulling the V_{CC} pin of a typical current-sense amplifier to ground places the part in shutdown mode, in which it draws no quiescent current from its input pins, only a small leakage current. Thus, the V_{CC} pin of a high-side current-sense amplifier can serve as a shutdown pin.

Method 1

Consider a typical battery-operated device in which a power source such as an LDO powers several ICs on a circuit board, including a [MAX4173F](#) high-side current-sense amplifier. To extend battery life by saving power, the system frequently turns off the LDOs and, therefore, the current-sense amplifier as well (**Figure 1**).

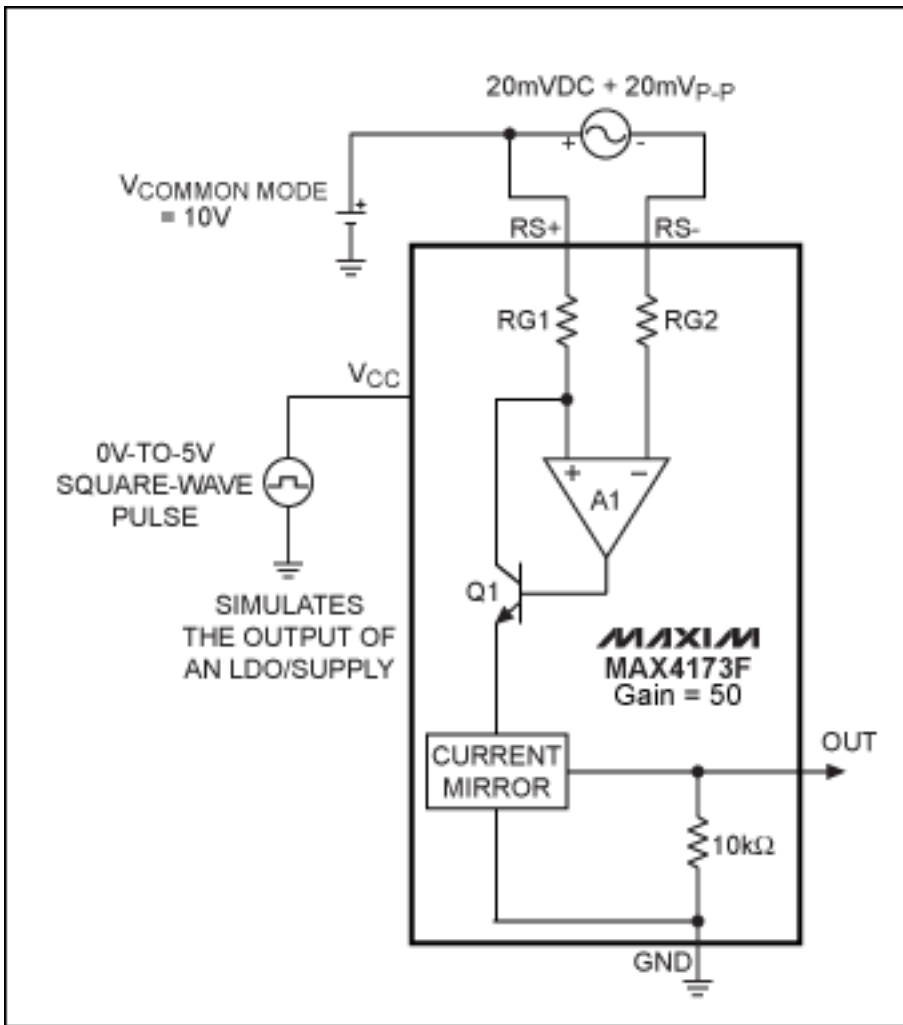

Figure 1. Zero volts on the V_{CC} pin of a current-sense amplifier (in this case, the MAX4173F) effectively shuts it down.

Typically, the inputs of the MAX4173F are connected to a current-sense resistor in the power-supply line. To simulate the affect of a shutdown signal, a differential 20mV_{p-p} AC signal, offset by a 20mV DC signal, rides on a 10V common-mode input voltage and is applied to the part. Loss of V_{CC} is simulated by a 0V -to- 5V square wave at the V_{CC} pin. During 5V intervals at V_{CC} , the amplifier operates in its active mode. During 0V intervals, however, it goes into shutdown. Because the amplifier gain is 50, the expected output is:

$$50 \times (20\text{mV}_{p-p} + 20\text{mV})$$

Consequently, the output is a 1V_{p-p} sine wave offset by 1V (**Figure 2**). As expected, the amplifier is active when 5V is applied, and it produces the expected output. When V_{CC} goes to 0V , the output also goes to 0V and the device shuts down, drawing no input or supply current.

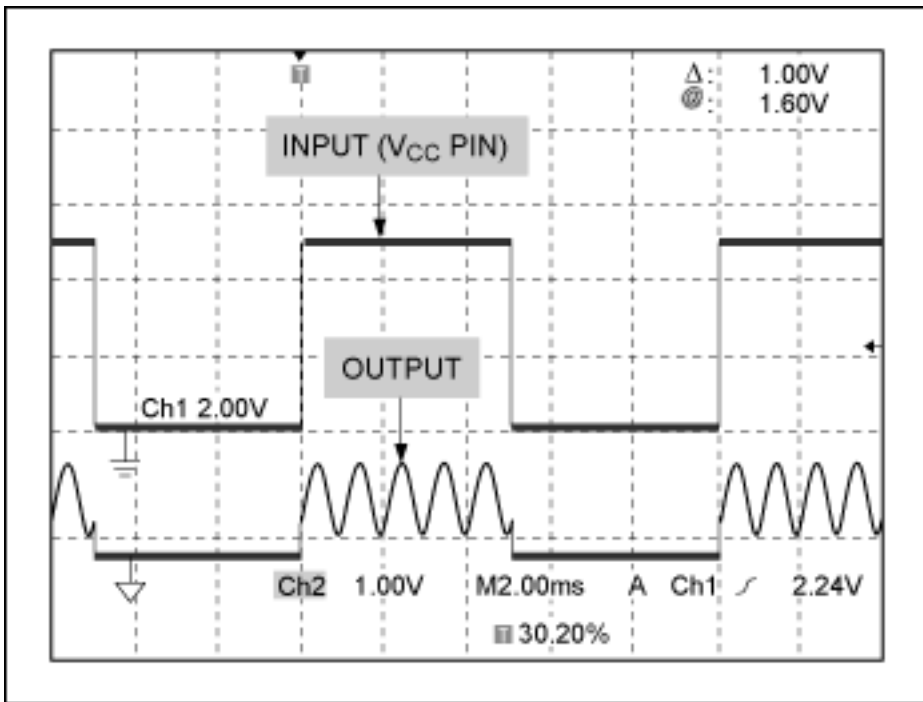

Figure 2. These waveforms illustrate the effect of shutting down a high-side current-sense amplifier using the method shown in Figure 1. The amplifier draws no quiescent current when V_{CC} is 0V.

Method 2

Another way of shutting down a current-sense amplifier is to connect an nMOS transistor in the ground path (**Figure 3**), and drive it with logic-level signals capable of turning the transistor on and off. When the transistor is on, the amplifier operates normally. The drain-source drop across the transistor causes negligible offset and gain error when referred to the inputs. When the transistor is off, the amplifier shuts down because its ground is floating.

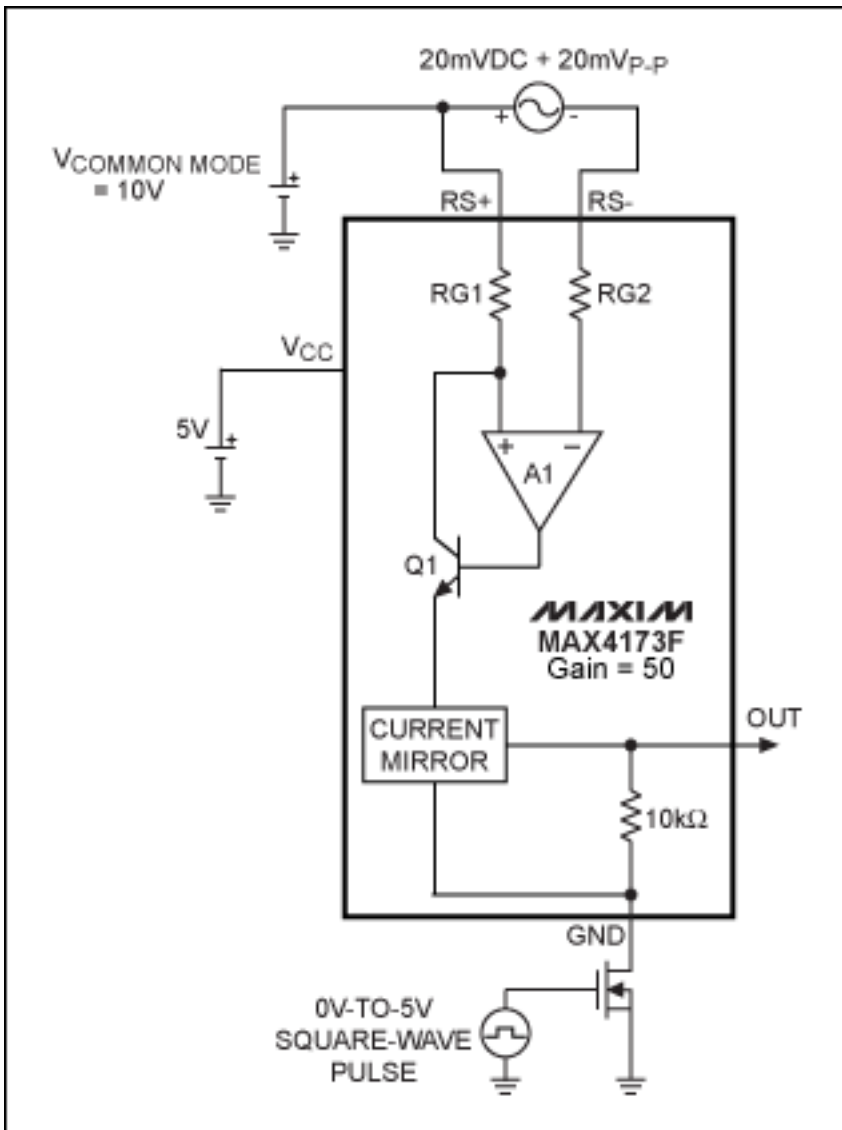

Figure 3. Opening the GND terminal of the MAX4173F also shuts it down.

The output waveform in **Figure 4** demonstrates the expected behavior: amplifying the input signal during 5V intervals, and floating close to V_{CC} during 0V intervals. During the shutdown intervals, the leakage current measured at the V_{CC} pin is just $4\mu\text{A}$, due to the $1\text{M}\Omega$ input impedance of the measurement scope. When the scope probe is absent, only the nMOS transistor's leakage current is drawn from V_{CC} . Input current on the $RS+$ and $RS-$ pins is just $0.3\mu\text{A}$.

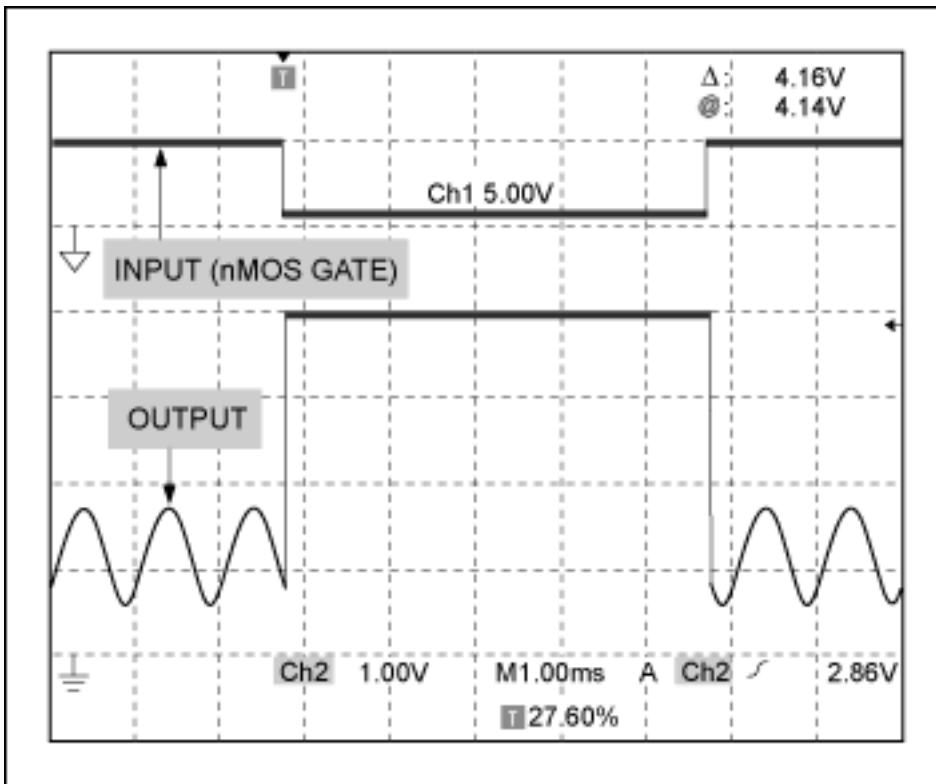

Figure 4. With the ground connection open, the high-side current sense amplifier of Figure 3 shuts down, drawing no quiescent current.

Summary

Thus, one can easily put the MAX4173F in shutdown mode either by pulling its V_{CC} pin to ground, or by opening its ground connection using an nMOS transistor. The first method depends on the availability of an LDO that can be turned off in the application. The second method requires an additional external FET. Both methods are useful for managing power in next-generation, portable multimedia devices. These schemes extend battery life, while still delivering an enriched user experience. Similar results can be expected from other high-side current-sense amplifiers.

A similar design idea appeared in the November 2007 issue of *Power Electronics Technology*.

Application Note 4235: www.maxim-ic.com/an4235

More Information

For technical support: www.maxim-ic.com/support

For samples: www.maxim-ic.com/samples

Other questions and comments: www.maxim-ic.com/contact

Automatic Updates

Would you like to be automatically notified when new application notes are published in your areas of interest?

[Sign up for EE-Mail.](#)

Related Parts

MAX4173F: [QuickView](#) -- [Full \(PDF\) Data Sheet](#) -- [Free Samples](#)

