

APPLICATION NOTE 423

# Latching Regulator Prevents Deep Discharge of Battery

*Abstract: In systems employing rechargeable batteries, it is important to disconnect the load before the battery enters deep discharge, which may destroy or damage the cell. This circuit turns off the circuit before the battery enters deep discharge and provides enough time for  $\mu$ C housekeeping activities.*

A rechargeable battery's load should be removed at the point of complete discharge, to avoid a further (deep) discharge that can shorten its life or destroy it altogether. Because a battery's terminal voltage recovers when its load is removed, you can't simply disconnect the load when the terminal voltage dips below the established threshold and then re-connect it when the voltage returns above that threshold. Such action may produce chatter in the disconnect switch.

The voltage of a discharged cell returns almost to the level of a fully charged cell, so hysteresis can't necessarily compensate for the recovery effect either. What's needed is a circuit that disconnects the load from the battery and keeps them separate until an external signal (such as that from a battery charger or pushbutton switch) indicates that the battery has been recharged or replaced.

Such a circuit can enlist the low-battery comparator in a low-dropout linear regulator (Figure 1). In this circuit, the low-battery comparator and error amplifier share the internal reference and the external resistor divider. With the resistor values shown, the low-battery output (LBO) goes low and disconnects both the battery and load when the output falls eight percent below its nominal value. The battery and load then remain disconnected until commanded otherwise by S1.

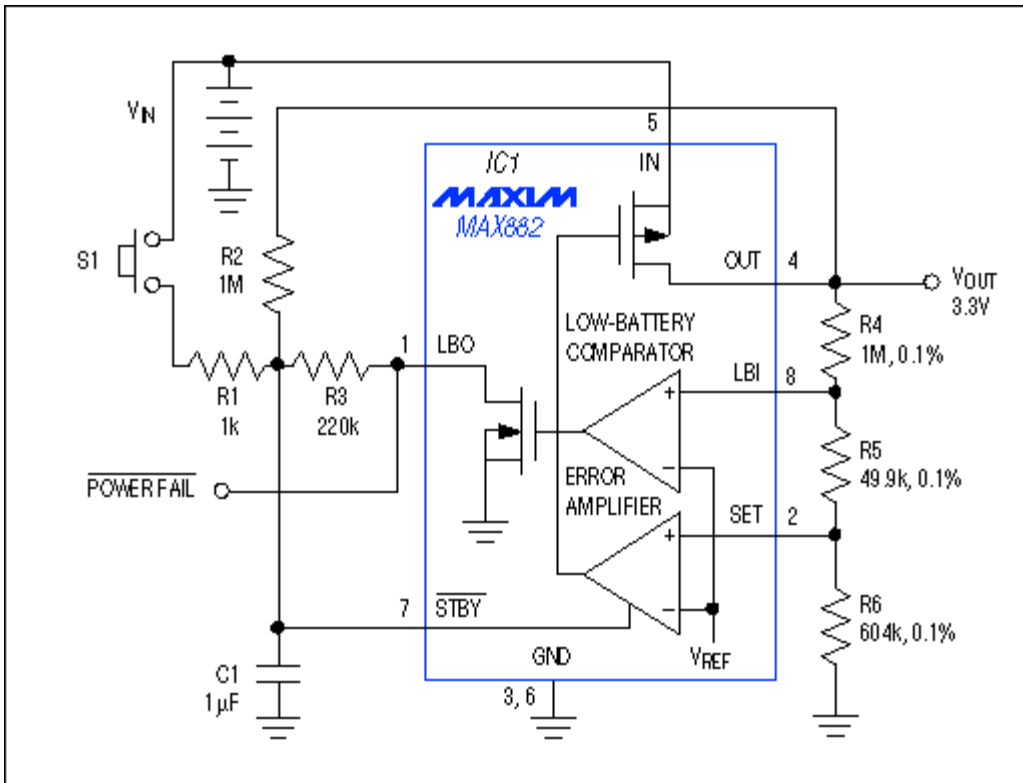

Figure 1. To protect the battery, this circuit disconnects the load before the battery enters deep discharge. To reconnect, you must press S1.

Two factors enable the latching action in this circuit: the low-battery comparator remains active during shutdown (most regulators deactivate this comparator during shutdown), and the circuit monitors the regulated output voltage instead of the battery voltage (regulator voltage can't recover until the regulator is turned back on).

The circuit also provides an active-low POWER FAIL signal (LBO, pin 1) that goes low 50ms before the output is turned off (Figure 2). This signal can provide a controlling microprocessor time to perform housekeeping and shutdown functions. When LBO goes low, C1 discharges through R3 until the active-low STBY input reaches its threshold (1.15V). The IC then enters its standby mode and disconnects the battery. IC1 is a linear regulator capable of sourcing 150mA with a 350mV dropout voltage. It has a 10 $\mu$ A standby current and accepts input voltages to 11.5V.

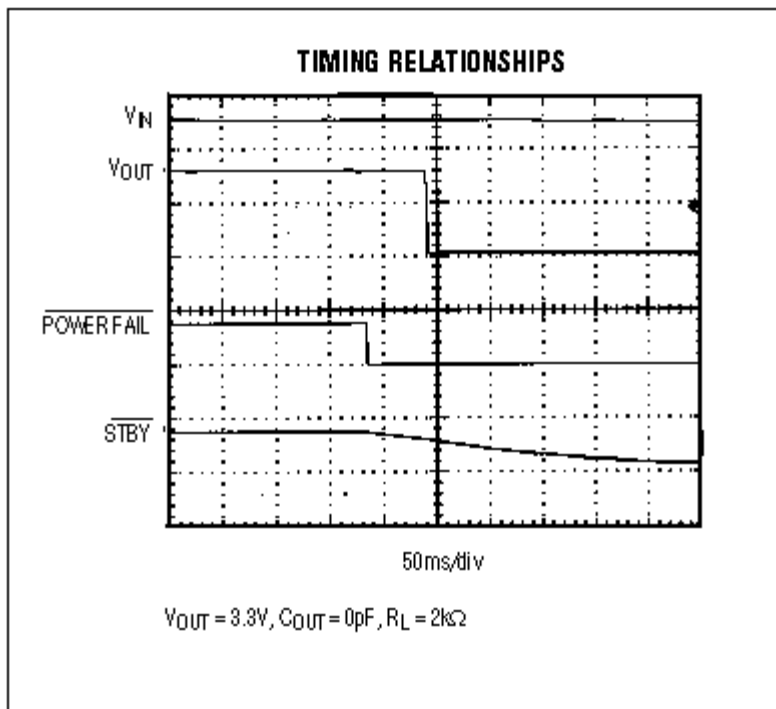

Figure 2. These waveforms illustrate timing relationships in the circuit of Figure 1.

A related idea appeared in the 3/16/95 issue of EDN.

---

#### Related Parts

[MAX882](#) 5V/3.3V or Adjustable, Low-Dropout, Low- $I_Q$ , 200mA Linear Regulator with Standby Mode -- [Free Samples](#)

---

#### Automatic Updates

Would you like to be automatically notified when new application notes are published in your areas of interest? [Sign up for EE-Mail™](#).

---

Application note 423: [www.maxim-ic.com/an423](http://www.maxim-ic.com/an423)

More information

For technical support: [www.maxim-ic.com/support](http://www.maxim-ic.com/support)

For samples: [www.maxim-ic.com/samples](http://www.maxim-ic.com/samples)

Other questions and comments: [www.maxim-ic.com/contact](http://www.maxim-ic.com/contact)

---

AN423, AN 423, APP423, Appnote423, Appnote 423

Copyright © by Maxim Integrated Products

Additional legal notices: [www.maxim-ic.com/legal](http://www.maxim-ic.com/legal)