



APPLICATION NOTE 4222

DS1863; DS1865; DS1875: How to Interface to MAX3735 or MAX3741 Compact Laser Driver

Abstract: This article describes how to interface the DS1863, DS1865, or DS1875 PON controller/monitor circuits to a compact laser driver. The MAX3736 or MAX3741 are the SFP laser drivers used in this application. The controllers provide SFF-8472-compliant digital diagnostics, laser calibration, laser control, and power leveling functionality.

The Controllers

The [DS1863](#), [DS1865](#), and [DS1875](#) controllers provide two outputs for controlling the laser driver: BIAS and MOD. BIAS is a 13-bit current DAC with a full-scale range of 1.2mA. The MOD output is an 8-bit voltage DAC with a full-scale range of 1.25V.

The Compact Laser Driver

The [MAX3736](#) or [MAX3741](#) laser driver has two inputs for laser control: BIASSET and MODSET. Both inputs should be connected to a current-sink controller with 1.2mA full-scale range in order to utilize the laser driver's full output range.

Interface Between Controller and Laser Driver

The controller's BIAS output provides the correct range for the BIASSET input of the laser driver. The MOD output is voltage mode, so must be adapted to interface to the laser driver (**Figure 1**).

Voltage-to-Current Conversion

An operational amplifier and NPN transistor are used to create a 1.2mA full-scale output from the MOD voltage-DAC output. The MOD output ranges from 0V to 1.25V. The NPN needs to sink current from the MODSET pin, which is maintained at 1.2V. R1 is chosen to keep the voltage at the NPN's emitter to less than 0.3V, and this ensures that the NPN does not saturate at full-scale current. The maximum full-scale current sunk by the NPN is set by the equation: $I_{MAX} = R2 \times 1.25V / (R1 \times (R3 + R2))$.

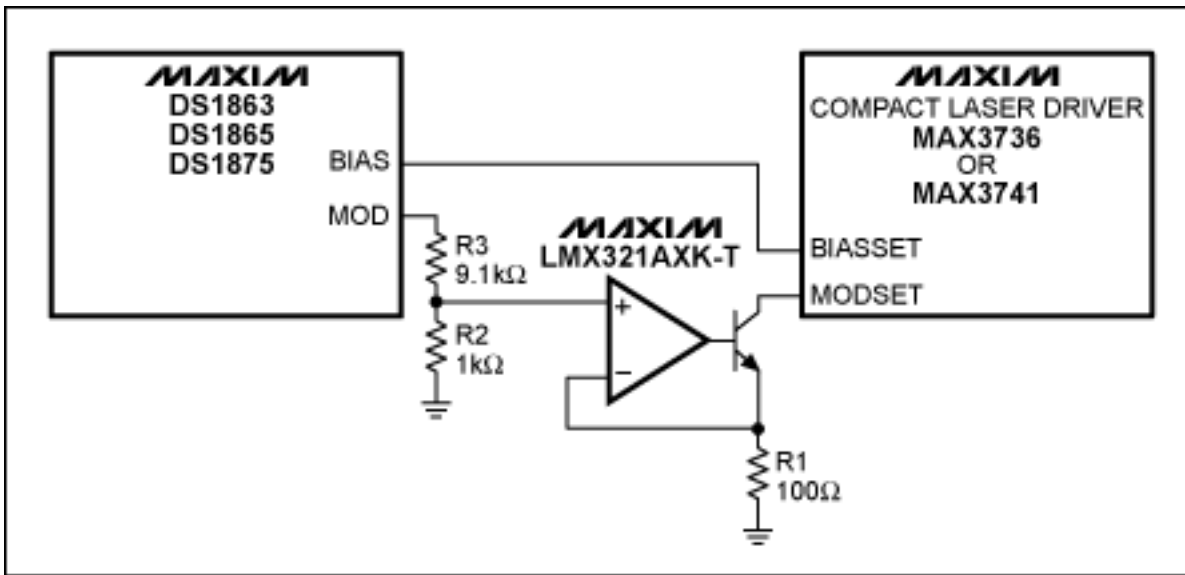

Figure 1. Controller-to-laser-driver interface.

Component Selection

This application does not require special components. A generic operational amplifier and NPN transistor can be used; the smallest, most affordable components will perform adequately in this application. The Maxim [LMX321AXK-T](#) operational amplifier is available in a 2.1mm x 2.0mm SC70-5 package. An NPN such as a 2N3904 or 2N2222 is also sufficient.

Conclusion

A small, simple, inexpensive circuit can be used to interface the DS1863, DS1865, or DS1875 PON controller/monitor to a compact laser driver. This interface circuit can be implemented in less than 9mm².

Application Note 4222: www.maxim-ic.com/an4222

More Information

For technical support: www.maxim-ic.com/support

For samples: www.maxim-ic.com/samples

Other questions and comments: www.maxim-ic.com/contact

Automatic Updates

Would you like to be automatically notified when new application notes are published in your areas of interest?

[Sign up for EE-Mail™.](#)

Related Parts

DS1863: [QuickView](#) -- [Full \(PDF\) Data Sheet](#) -- [Free Samples](#)

DS1865: [QuickView](#) -- [Full \(PDF\) Data Sheet](#) -- [Free Samples](#)

DS1875: [QuickView](#) -- [Full \(PDF\) Data Sheet](#)

MAX3736: [QuickView](#) -- [Full \(PDF\) Data Sheet](#) -- [Free Samples](#)

MAX3741: [QuickView](#) -- [Full \(PDF\) Data Sheet](#)

AN4222, AN 4222, APP4222, Appnote4222, Appnote 4222
Copyright © by Maxim Integrated Products
Additional legal notices: www.maxim-ic.com/legal