



APPLICATION NOTE 4180

Optimizing the Load-Switch Function of the DS2715 Battery-Charger IC

Abstract: Integrating a battery-load switch function into a smart-charger IC greatly benefits low-cost applications. The DS2715 battery-charger IC intelligently senses battery loading after removal of the charge source to seamlessly maintain power to connected loads. This application note details examples of several application circuits that optimize the performance of the DS2715. Specifically, it presents a circuit for applications in which the DS2715 is connected to noncontinuous loads, and a circuit for powering the load directly from batteries.

Introduction

The [DS2715](#) is unique compared to other charging ICs in that it provides a charging *and* discharging path to battery cells through a single transistor. This functionality, combined with its 10-cell charging capacity, makes it a very popular charging solution for many types of battery-powered devices. Explaining exactly how the DS2715 controls the regulation transistor, this application note describes circuit adjustments that designers can make to optimize their DS2715 application. First, it details a typical application circuit for a 3-cell battery pack. Then, it presents two alternate circuits: an improved circuit for applications in which the DS2715 is connect to loads that operate noncontinuously, and a circuit for powering the load directly from batteries.

Typical Application Circuit

Figure 1 shows a typical switch-mode application circuit for a 3-cell battery pack. (All of the examples described in this application note can also be applied to the linear-mode circuit.) When the charge source is connected, it powers the load directly through D1 and powers the DS2715. The DS2715 then executes its charging functions as usual. When the charge source is disconnected, the charge current ceases, and the battery supplies power to the DS2715 through the parasitic diode of Q1. Load current is also supplied through this path. If the load current causes the voltage across the sense resistor to exceed 10mV (typ, as measured from SNS+ to SNS-), and V_{DD} is sufficient to maintain operation, the DS2715 enters discharge mode.

approximately the battery voltage as the decoupling capacitors C1 and C2 discharge. **Figure 2** shows the transition at the load node as the charge source is removed. In order to maintain sufficient V_{DD} to the DS2715, four cells were used and a $470\mu\text{F}$ capacitor was used in place of C1 to decouple the 500mA load current.

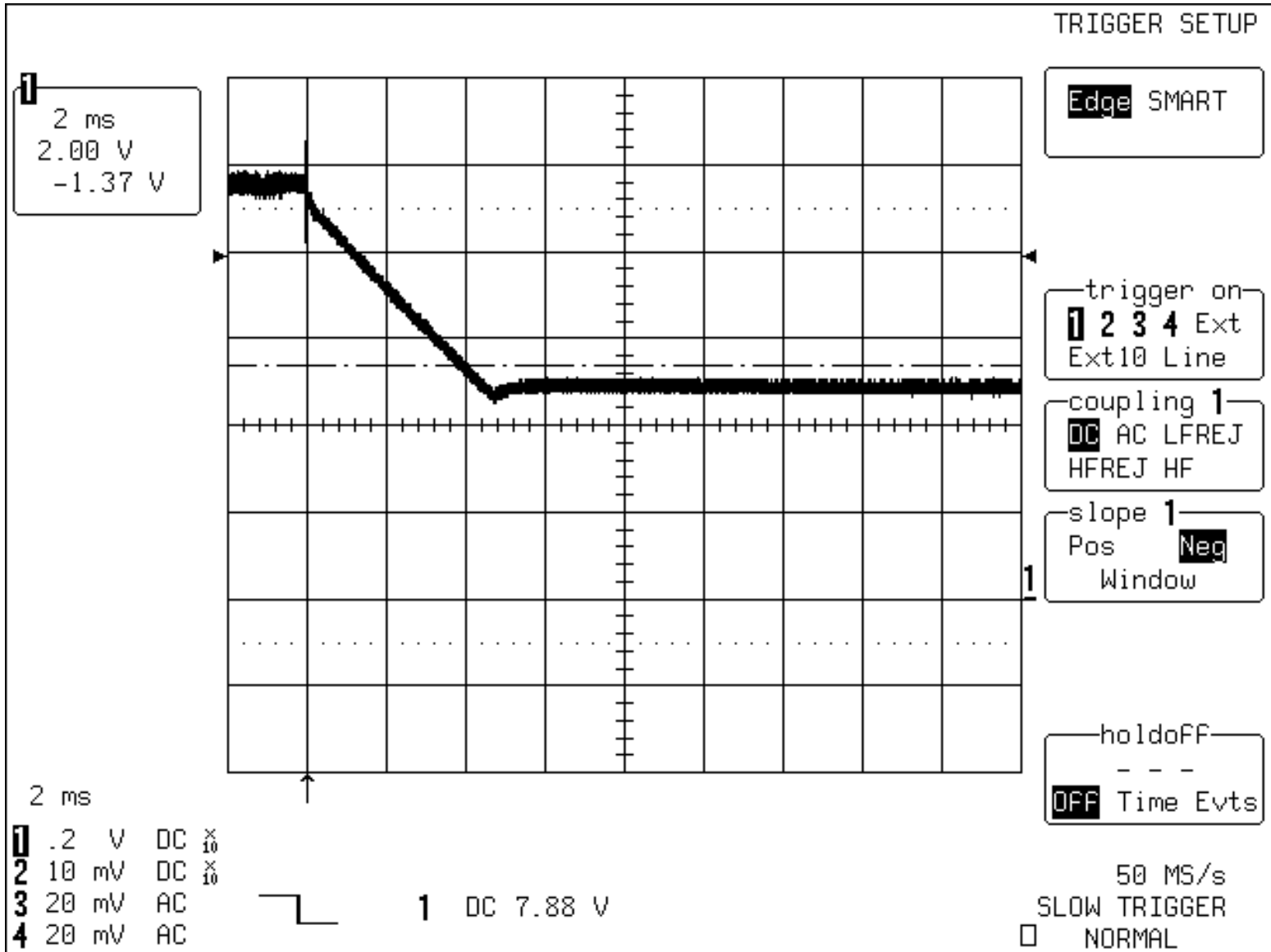

Figure 2. 4-cell switch-mode circuit transient performance for charge-source removal, $C1 = 470\mu\text{F}$.

This basic application circuit works well for 3-cell or less applications that will not rely on discharge mode, or 4+ cell applications. There is a disadvantage, though, in 4+ cell circuits in which the batteries will be charged very infrequently and the circuit will be in discharge mode for many days at a time. In that case, the static current consumed to keep Q1 in discharge mode may drain more battery energy than can be tolerated. In 4+ cell applications in which the load will not be in use for significant portions of time and the batteries are expected to last for many days or more, a few minor modifications to the basic circuit can improve performance. These modifications are equally helpful for adding an equivalent discharge-mode functionality to 2- and 3-cell applications.

Improved Application Circuit

Whenever loads operate in short and infrequent intervals with battery power, it is best to minimize the battery drain during periods of inactivity to extend battery life. The DS2715's typical application circuit can be modified with one transistor and a few passive components to significantly improve its performance when it is intended to be connected to loads that operate noncontinuously. **Figure 3** presents the modified circuit.

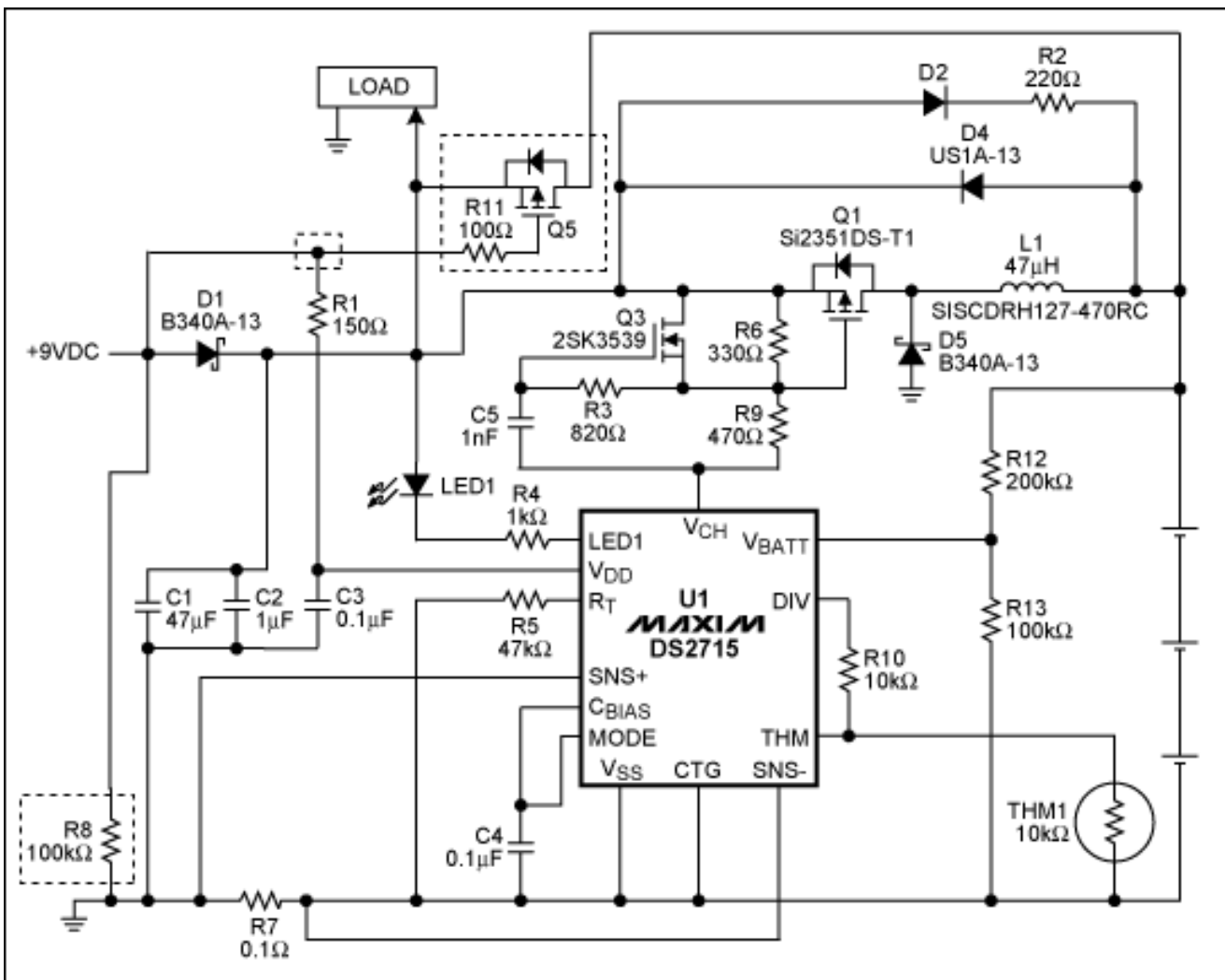

Figure 3. Improved switch-mode application circuit for applications in which the DS2715 is connected to noncontinuous loads.

The first important modification is the addition of Q5. It should be a pFET with very low $R_{DS(ON)}$ to maximize power delivery efficiency. Its V_{GS} should be chosen based on the circuit and load requirements. Ideally, Q5 should be chosen so that its V_{GS} will keep it in an on state at the lowest useful battery voltage. A V_{GS} rating that also will begin to shut off Q5 when the battery voltage drops below useful limits helps limit overdischarge of the battery. This feature may not be a requirement for most circuits since the load often will power down long before overdischarge occurs, and NiMH cells are reasonably tolerant of some overdischarge. Q5 should be rated for the maximum voltage conditions that it will see; it should also be able to handle the maximum load current and the associated power dissipation. R8 is included in the circuit to make sure that Q5 is turned on when the charge source is removed. R11 can be part of slew-rate control for Q5 switching transitions, or other components can be substituted for it to provide ESD (electrostatic discharge) protection for the FET as necessary.

The other necessary modification is to power the DS2715 directly from the charge source by moving the R1 connection from the anode of D1 to the cathode. This causes the DS2715 to power down whenever the batteries might be powering the load, allowing Q5 to act as the load switch. When the DS2715 is powered down and the load is disconnected, battery capacity will only be reduced by small leakage currents and the self-discharge of the battery itself. Powering down the DS2715 also resets the internal state machine to restart the charge cycle, which was accomplished by Q2 in the typical application circuit (Figure 1). The improved circuit allows the battery to discharge properly, even with less than four cells, when it would otherwise not sufficiently power the DS2715 in a discharge state.

Another benefit of this topology is that separate charge and discharge transistors can be chosen to optimize the characteristics most important to each function. Important characteristics of the load-connecting transistor have already been mentioned. For Q1 in the switch-mode application, a transistor with a low V_{GS} is desired to optimize the simple bootstrap turn-off helper circuit that includes Q3. Also, a reasonable compromise between low R_{DS} and low gate charge will produce a circuit with adequately low overall power losses. For the linear-mode regulation transistor, the power-dissipation rating is typically the most important factor.

Since this circuit directly connects the batteries to the load, it is recommended that the load be of the type that shuts itself off when the supply voltage drops too low. If a resistive load were connected, the load could overdischarge the batteries.

Improved Application Circuit Performance

The following figures show the transient response of the improved application circuit to the removal of the charge source. **Figure 4** shows the results with a 22 μ F aluminum electrolytic capacitor populated for C1. **Figure 5** shows the same results with the capacitor value changed to 470 μ F. The load voltage transitions from the charge-source level to the battery level as the load FET is turned on. The load in this case was a 500mA current sink. The charge source prior to removal was 9V, which supplied both the load and the charging operation. In both figures, the top trace corresponds to the voltage of the load node, and the bottom trace corresponds to the voltage of the Q5 gate. Both voltages are ground referenced.

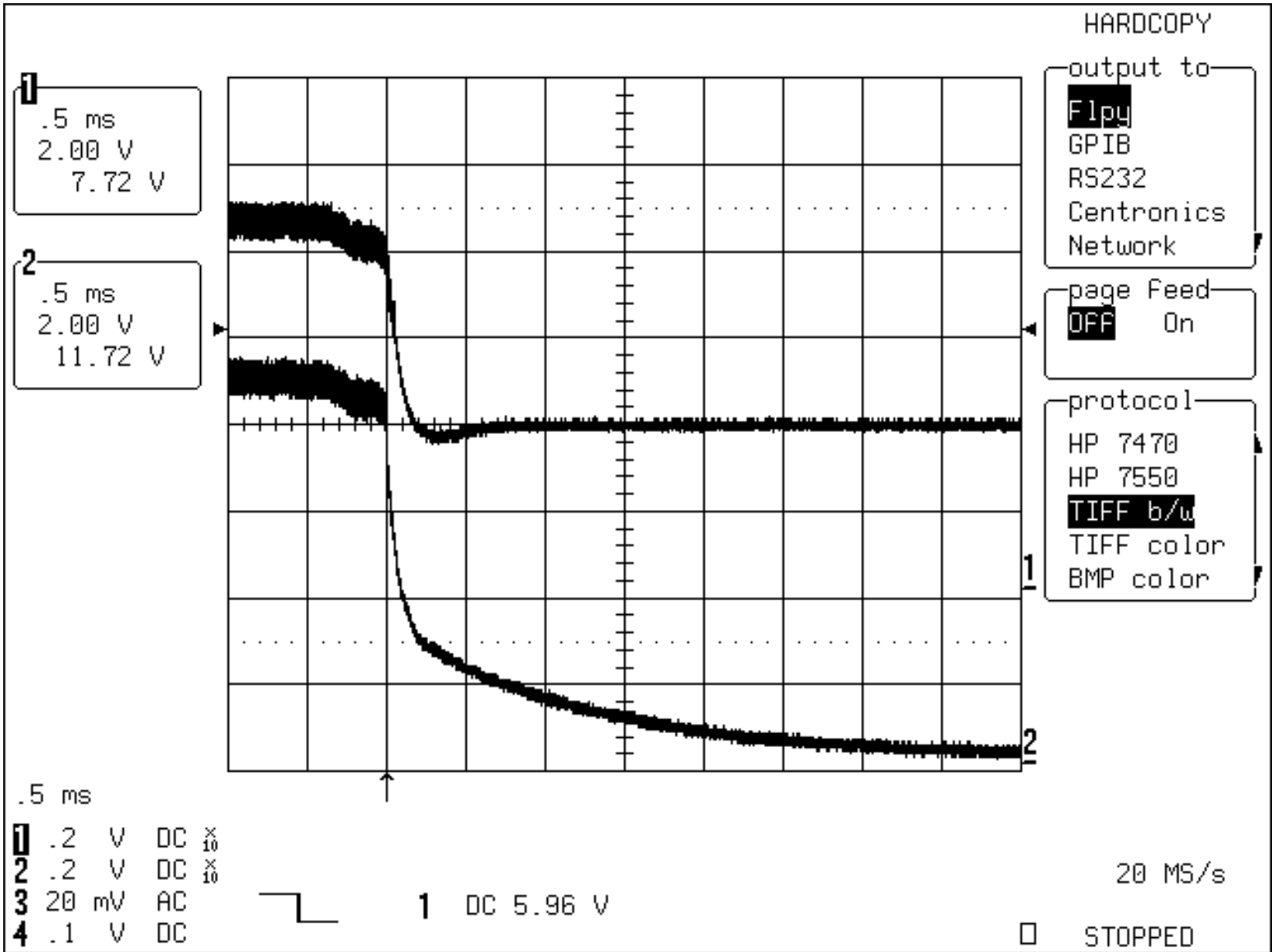

Figure 4. Transient waveforms for charge-source removal with the improved application circuit, C1 = 22 μ F.

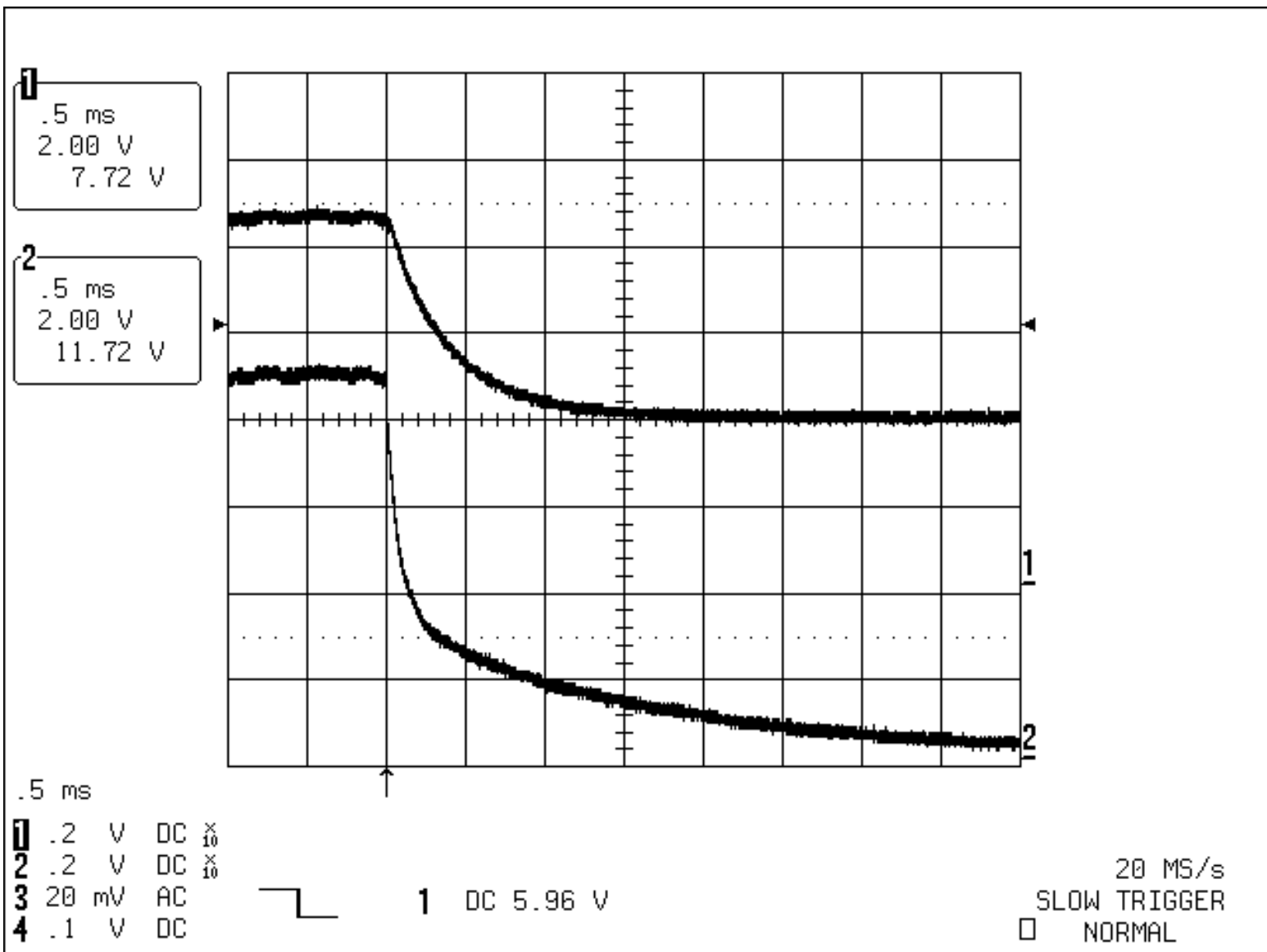

Figure 5. Transient waveforms for charge-source removal with the improved application circuit, $C1 = 470\mu\text{F}$.

When $C1$ is equal to $22\mu\text{F}$, a small amount of droop below the battery voltage occurs. Increasing the decoupling capacitance to $470\mu\text{F}$ eliminates the undershoot for this particular configuration of the battery, load, and circuit.

Powering the Load Directly from Batteries

In some cases, it may not be feasible to make the load tolerant of being supplied by both the charge-source voltage and the battery-pack voltage. The load could be powered directly from the batteries, but a couple of considerations must be taken into account. **Figure 6** provides a circuit for powering the load directly from batteries.

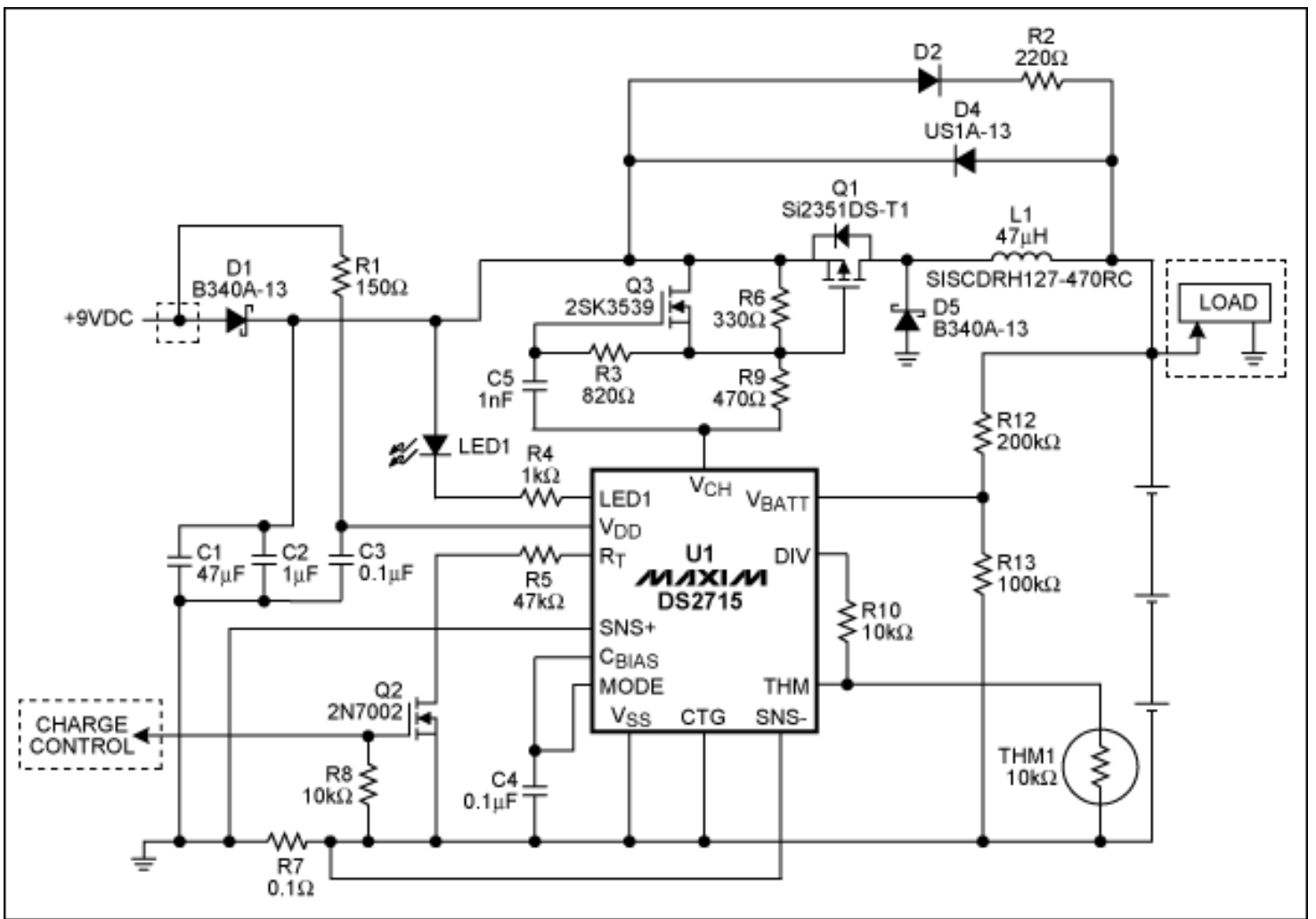

Figure 6. Application schematic for an alternate load connection point.

The load must be grounded as shown so that during charging the battery receives the intended charge current (the load current will not be flowing through the R7 sense resistor). Also, because the load is connected directly to the batteries, there is no need to use the discharge mode of the DS2715 or to draw extra current via the biasing circuit to turn on Q1. By moving the R1/C3 filter connection and, therefore, V_{DD} of the DS2715 directly to the charge source, the DS2715 is reset and not in use whenever the charge source is removed. In this configuration, once a charge is complete, all load current, except for the current through D2/R2, must be supplied by the batteries regardless of whether or not the charge source is connected. The application should be such that the unit is intended to be powered entirely by the batteries until ready for a new charge cycle.

In this configuration, the charging circuit, except for the sense resistor, also carries the load current. Consequently, all components must be sized for the worst case combination of charge current and load current. For the switch-mode case, it may be necessary to retune the bootstrap circuit that helps to turn off Q1 depending on the extra load current and its effect on switching performance. If there is any possibility of removing the batteries during charging, precautions should be taken to ensure that the load is tolerant of any inductive spike for switch mode that may occur even with the clamping components present. Extra bypass capacitors or special attention to layout may be necessary in some cases. Q2 and R8 may be included in this circuit as shown if there is a need to control when a charge is allowed to start or if a charge might need to be stopped by the application controller when the charge source still present. Whenever Q2 is used to stop a charge, the charge cycle returns to the presence detect state. Q2, therefore, should not be used to frequently stop and restart the charge since this could result in some overcharging, especially if done near the end of a charge cycle.

Conclusions

The DS2715 provides a unique, low-cost method for controlling the charging functions for NiMH battery packs, as well as a method for connecting the load for battery-powered operation. Depending on the number of battery cells used in the application and the characteristics of the load, a basic circuit with a few optional modifications can ensure good charging and load-powering performance for a wide range of applications.

Application Note 4180: www.maxim-ic.com/an4180

More Information

For technical support: www.maxim-ic.com/support

For samples: www.maxim-ic.com/samples

Other questions and comments: www.maxim-ic.com/contact

Keep Me Informed

Preview new application notes in your areas of interest as soon as they are published. Subscribe to [EE-Mail - Application Notes](#) for weekly updates.

Related Parts

DS2715: [QuickView](#) -- [Full \(PDF\) Data Sheet](#) -- [Free Samples](#)

AN4180, AN 4180, APP4180, Appnote4180, Appnote 4180

Copyright © by Maxim Integrated Products

Additional legal notices: www.maxim-ic.com/legal