

APPLICATION NOTE 4162

Reference Design for a Powered-Device (PD) Module Based on the MAX5941B PWM Controller

Abstract: This application note provides a reference design for an IEEE® 802.3af-compliant, 12.95W adjustable-output powered-device module. Assembled on a 12cm² PCB, the module is based on the MAX5941B PWM controller and includes hot-swap power switching, a DC-DC converter, and a pair of ORing diode bridges for compatibility with an external 12V adapter. This article details the performance of the module and provides a schematic, PCB layout, and components list for the design.



General Description

This application note presents an IEEE 802.3af-compliant, powered-device (PD) module for power-over-Ethernet (PoE) applications. Based on the [MAX5941B](#) PoE interface/PWM controller, this module provides the PD with a detection signature, a configurable classification signature (optional), programmable undervoltage lockout (UVLO), and an isolation switch with programmable inrush-current control.

The MAX5941B PD module is assembled on a 12cm² PCB and includes hot-swap power switching, a DC-DC converter, and a pair of ORing diode bridges for compatibility with an external 12V adapter. In short, it provides all the functions necessary to implement a DC-DC, fixed-frequency, isolated power supply for PDs, such as IP phones, wireless access nodes, and security cameras.

Typical Application

The MAX5941B PD module can be used in numerous applications. **Figure 1** illustrates a typical application in which the data outputs from the switch are connected to the inputs of a midspan. The midspan then adds power to the data on each output that supports PoE.

In this example, port 1 is connected to an Ethernet camera and port 2 is connected to a wireless access point. When the midspan is switched on (or when the device is connected), the midspan checks each output for a PoE signature. The module identifies the peripherals on ports 1 and 2 as PoE-enabled devices, and the midspan supplies both data and power to these peripherals.

The midspan continuously monitors each output to see if a PoE-enabled device has been added or removed. Since the other ports in this example do not have a PoE signature, the midspan only passes data through to the connected peripherals.

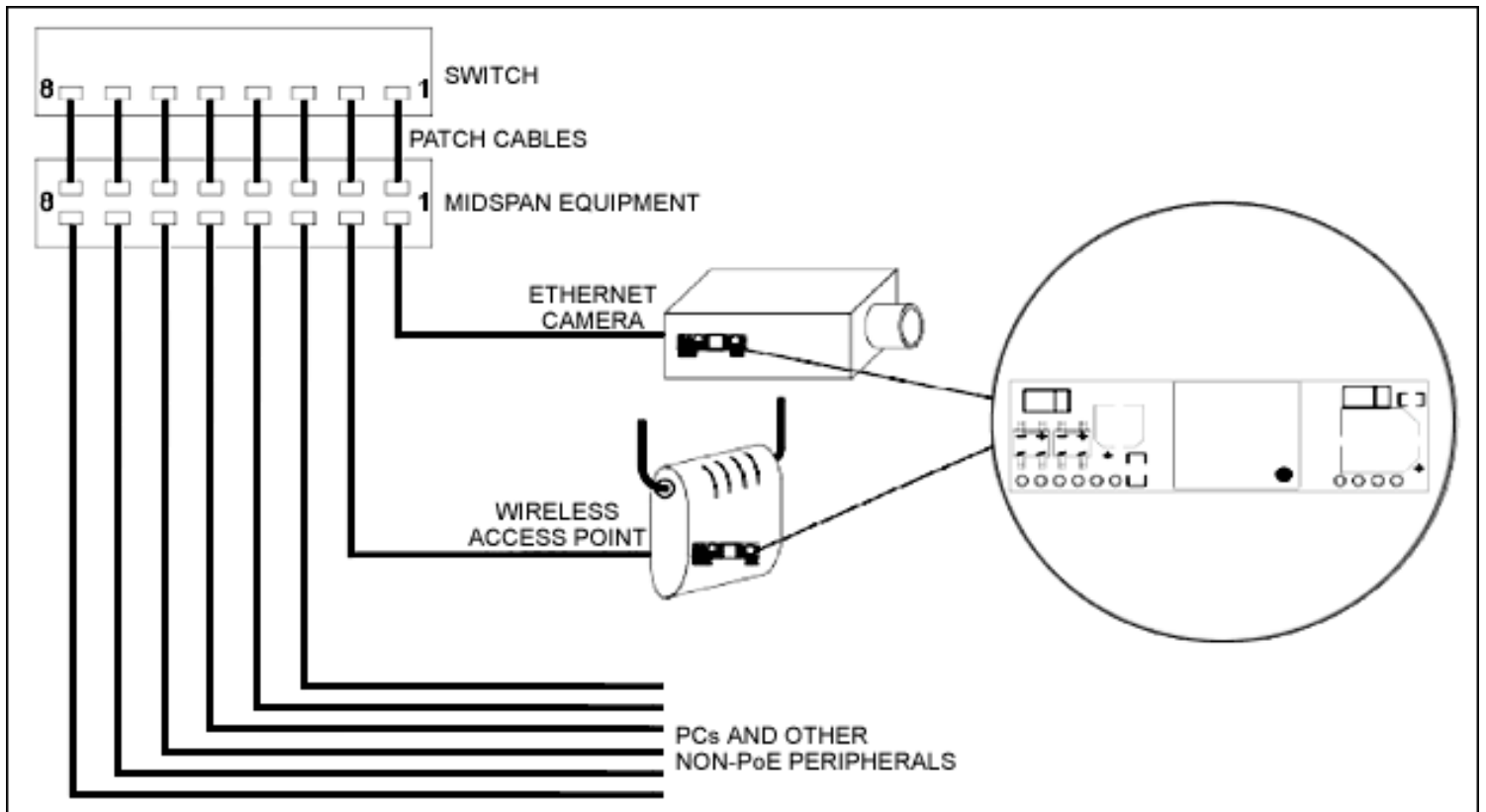

Figure 1. In a typical application, the data outputs from the switch are connected to a midspan, which adds power to the data to provide power over Ethernet.

Features

- IEEE 802.3af compliant
- 36V to 60V input voltage range
- 12V/1A output
- No minimum load requirement
- Small SIL package size
- Low output ripple and noise
- High-efficiency powered device
- No external capacitor required
- Adjustable output voltage
- Low cost
- 1500V isolation (input to output)
- On-board ORing diode used with an external 12V adapter

Pin Description

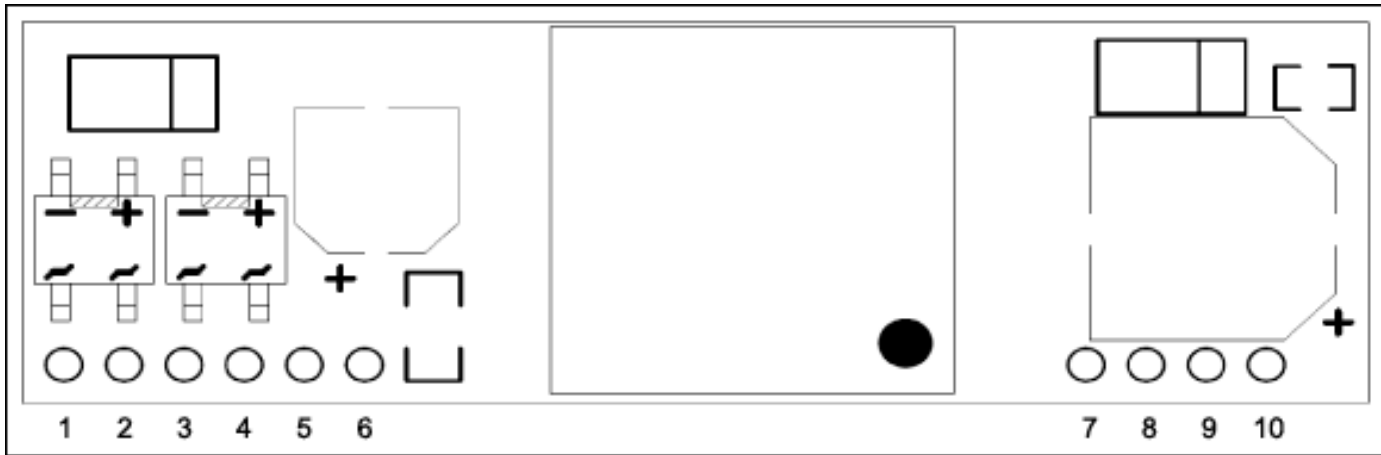

Figure 2. Pin assignment.

Table 1. Pin Description

Pin Number	Name	Description
1	VA1	Rx Input (1) This input pin is used in conjunction with VA2 and connects to the center tap of the transformer connected to pins 1 and 2 of the RJ45 connector (Rx)—it is not polarity sensitive.
2	VA2	Tx Input (2) This input pin is used in conjunction with VA1 and connects to the center tap of the transformer connected to pins 3 and 6 of the RJ45 connector (Tx)—it is not polarity sensitive.
3	VB1	Direct Input (1) This input pin is used in conjunction with VB2 and connects to pins 4 and 5 of the RJ45 connector—it is not polarity sensitive.
4	VB2	Direct Input (2) This input pin is used in conjunction with VB1 and connects to pins 7 and 8 of the RJ45 connector—it is not polarity sensitive.
5	CP1	Class Programming (1) Connecting an external resistor to CP2 will change the current class of the module. With no resistor fitted the module will default to Class 0.
6	CP2	Class Programming (2) Connecting an external resistor to CP1 will change the current class of the module. With no resistor fitted the module will default to Class 0.
7	GND	Ground The ground return for the output.
8	V _{OUT}	DC Output This pin provides the regulated output voltage from the DC-DC converter.
9	ADJ	Output Adjust The output voltage can be adjusted from its nominal output by connecting an external resistor from this pin to either the V _{OUT} pin or GND pin.
10	N.C.	No Connection This pin is not connected internally.

Power Classification

Power classification is an optional method for the PD to indicate its power requirements to the power-sourcing equipment (PSE). The MAX5941B module allows the current class to be externally programmed by connecting a resistor between the CP1 and CP2 pins, as shown in **Figure 3**. If no resistor is fitted, the module will default to Class 0. **Table 2** provides a full list of programming resistor values.

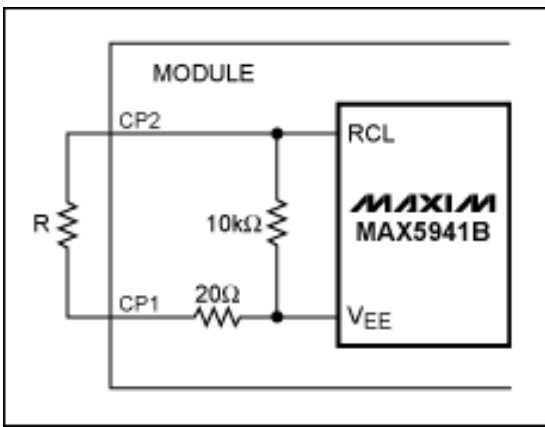

Figure 3. To set the power classification, connect a resistor between pins CP1 and CP2.

Table 2. Resistor Values for Programming the Power Class

Class	Programming Resistance (Ω)	Minimum Power (W)	Maximum Power (W)
0	Do not fit	0.44	12.95
1	770	0.44	3.84
2	388	3.84	6.49
3	242	6.49	12.95
4	161	Reserved	Reserved

Output Adjustment

The MAX5941B PD module has an ADJ pin to trim the output voltage up or down from its nominal value. To adjust the output voltage, connect a resistor between the ADJ pin and either the GND pin or the V_{OUT} pin (**Figure 4**). Equations 1 and 2 calculate the resistor values required to achieve the desired trimmed-up and trimmed-down output voltages.

$$R_{TRIM_UP} = \frac{23.825}{V_{TRIM_UP} - 12.068} - 20 \text{ (k}\Omega\text{)} \quad (\text{Eq. 1})$$

$$R_{TRIM_DOWN} = \frac{9.53 \times (V_{TRIM_DOWN} - 2.5)}{12.068 - V_{TRIM_DOWN}} - 20 \text{ (k}\Omega\text{)} \quad (\text{Eq. 2})$$

where V_{TRIM_UP} is the desired trimmed-up output voltage and V_{TRIM_DOWN} is the desired trimmed-down output voltage.

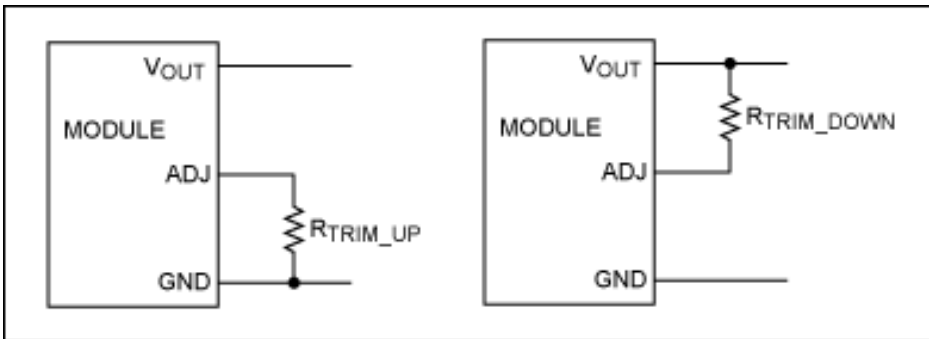

Figure 4. To adjust the output voltage, connect a resistor between ADJ and GND (trim up) or ADJ and V_{OUT} (trim down).

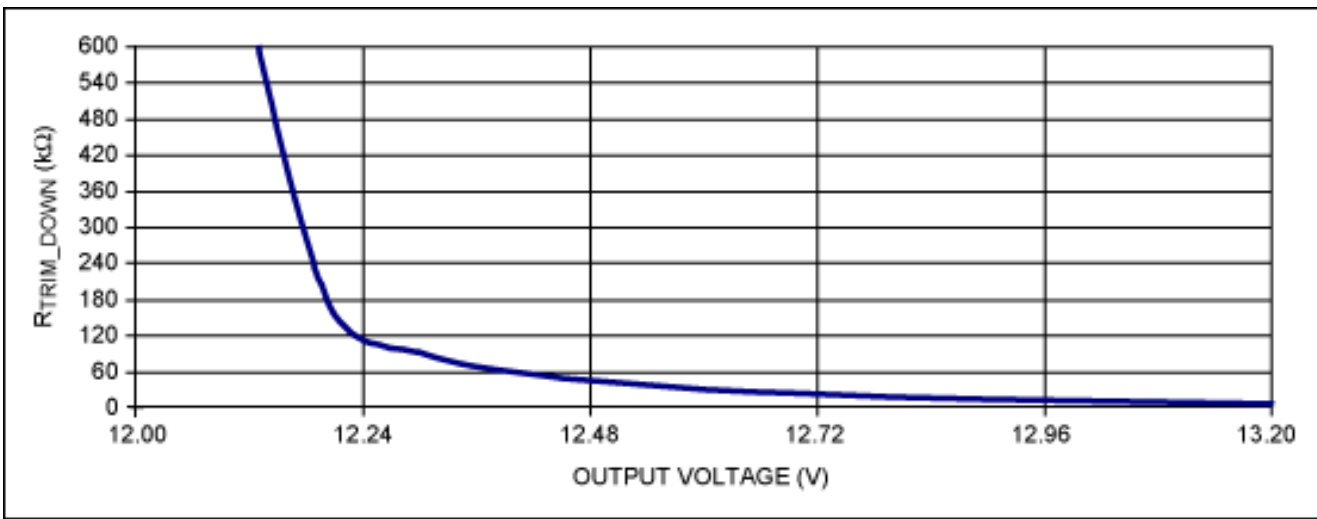

Figure 5A. The trimmed-up output voltage curve.

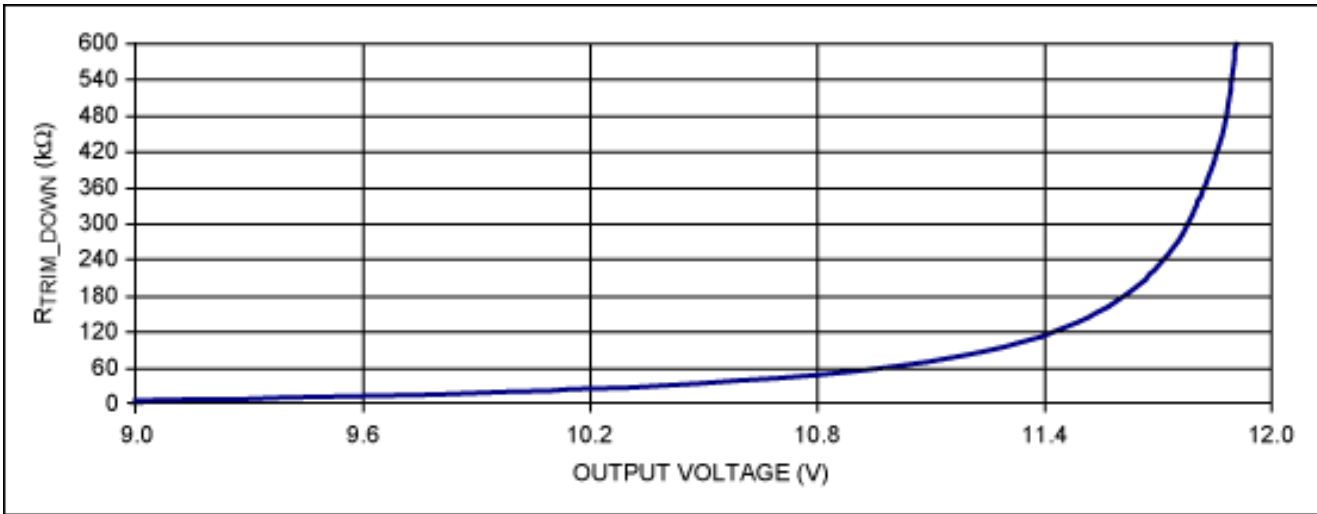

Figure 5. The trimmed-down output voltage curve.

Typical Connections with an External 12V Adapter

Conventionally, the PD is used simultaneously with an adapter, and a diode is connected in series at each output as shown in **Figure 6**.

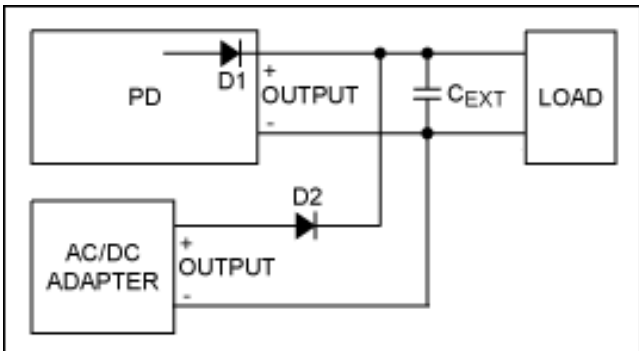

Figure 6. In the conventional solution, the powered device is connected to an adapter, with a diode placed in series at each output.

For the MAX5941B PD module, the output diode D1 is assembled internally. If the PD is used independently, replace the diode with a 0Ω resistor to improve efficiency. **Figure 7** shows the placement of the ORing diode D1 on the board.



Figure 7. The location of the internal diode D1 on the MAX5941B PD module.

The module only requires one external capacitor, as shown in **Figure 8**; minimally, a 1 μ F ceramic capacitor is recommended.

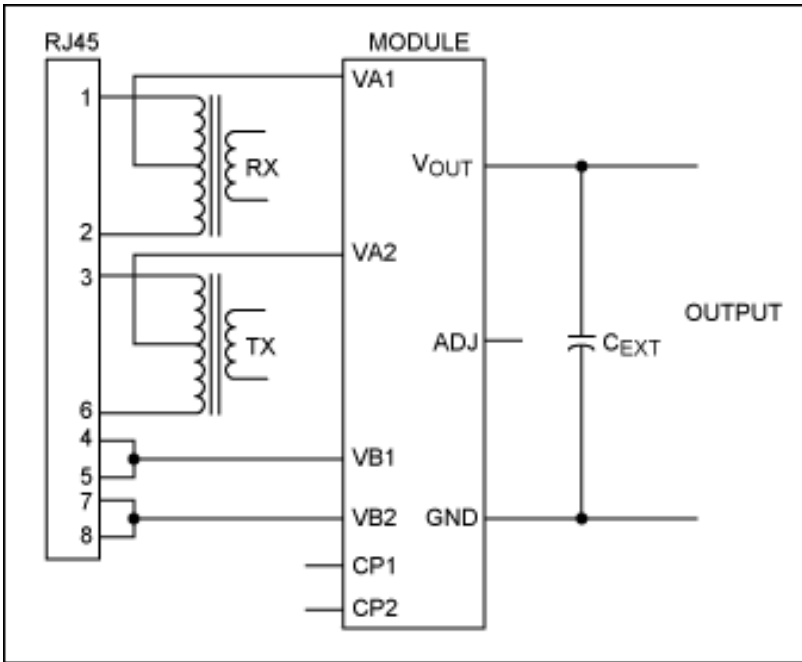

Figure 8. Typical connection diagram showing the external capacitor connected between GND and V_{OUT} .

Electrical Characteristics

Table 3. Absolute Maximum Ratings

Parameter	Min	Typ	Max	Units
DC Supply Voltage	-0.3		60	V
DC Supply Voltage Surge for 1ms	-0.6		80	V
Storage Temperature	-40		+100	°C

Stresses beyond those listed under "Absolute Maximum Ratings" may cause permanent damage to the module. These are stress ratings only, and functional operation of the module at these or any other conditions beyond those indicated is not implied. Exposure to absolute maximum ratings conditions for extended periods may affect the module's reliability.

Table 4. Recommended Operating Conditions

Parameter	Min	Typ	Max	Units
Input Supply Voltage	36	48	60	V
Undervoltage Lockout	30		36	V
Operating Temperature	-40	25	+85	°C

Table 5. DC Electrical Characteristics

Parameter	Min	Typ	Max	Units
Nominal Output Voltage (Without the ORing Diode)	11.76	12	12.24	V
Output Current	0		1	A
Output Ripple and Noise			250	mV
Efficiency Without the ORing Diode (48V Input, 1A Output)		85		%
Efficiency with the ORing Diode (48V Input, 1A Output)		82		%
Isolation Voltage			1500	V

Waveforms

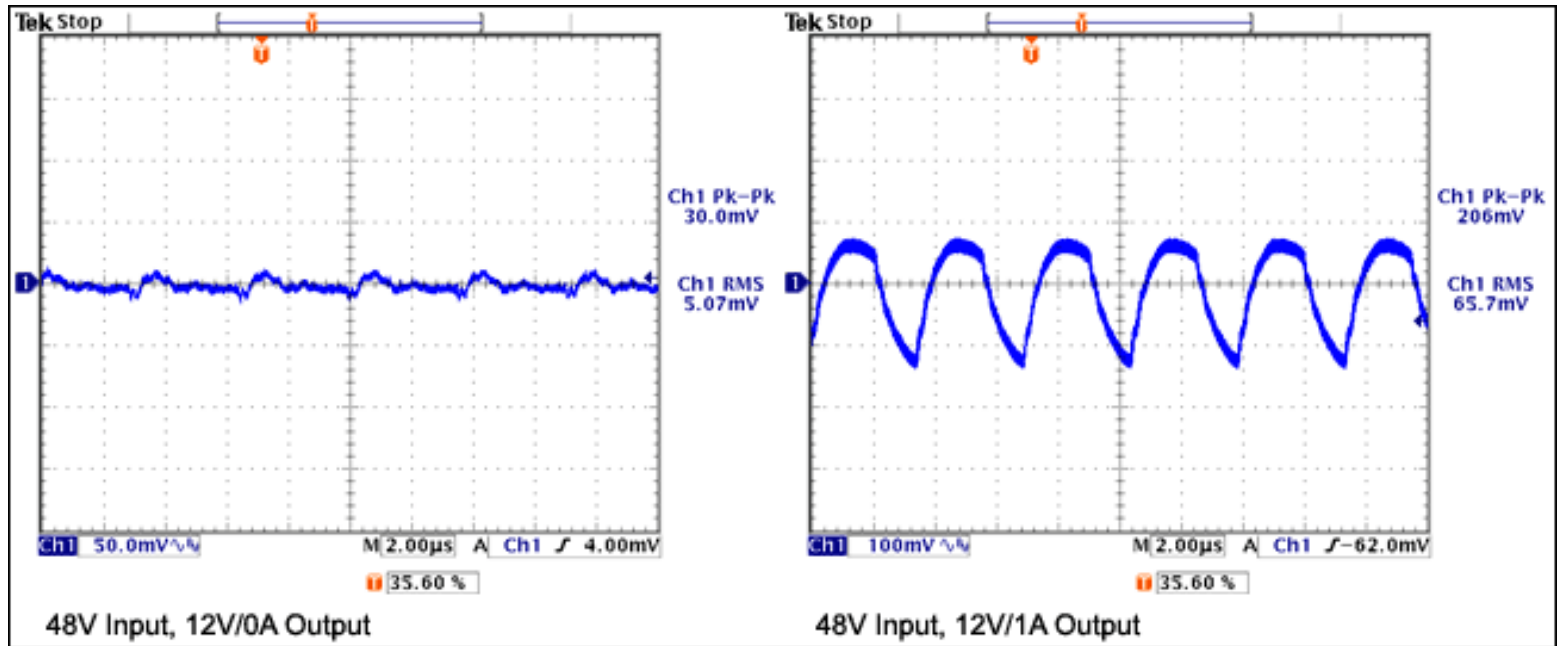
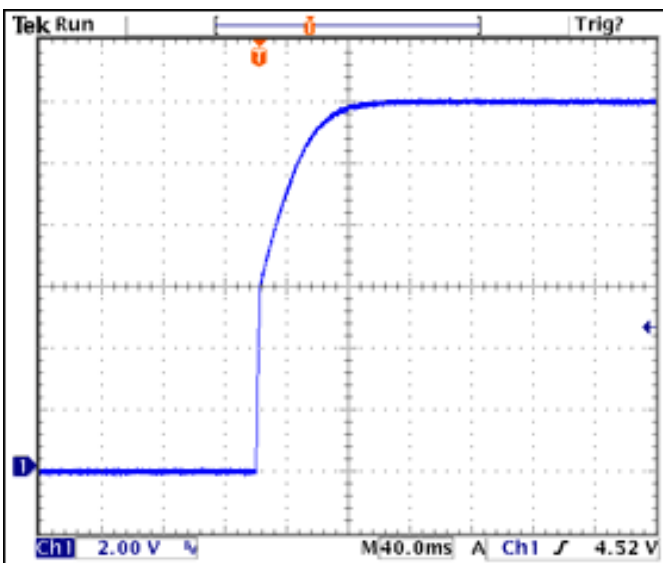
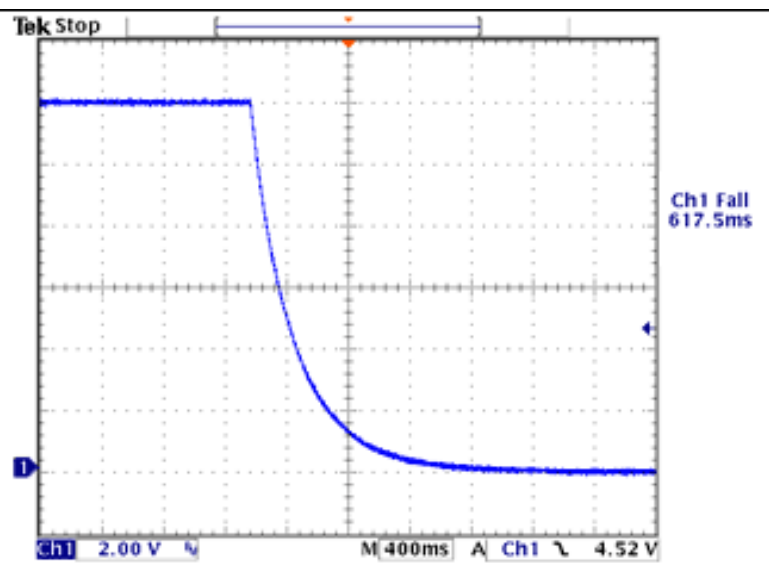

Figure 9. Output ripple and noise.



Startup at 48V Input, 12V/0A Output



Shutdown at 48V Input, 12V/0A Output

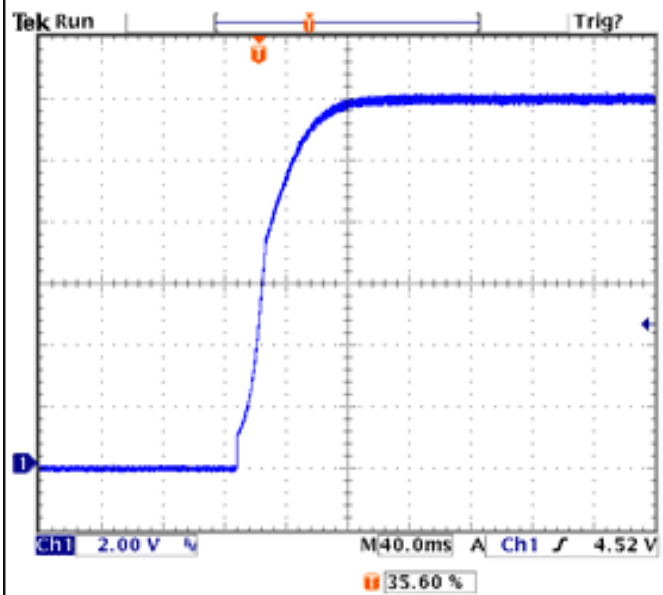

Startup at 48V Input, 12V/1A Output

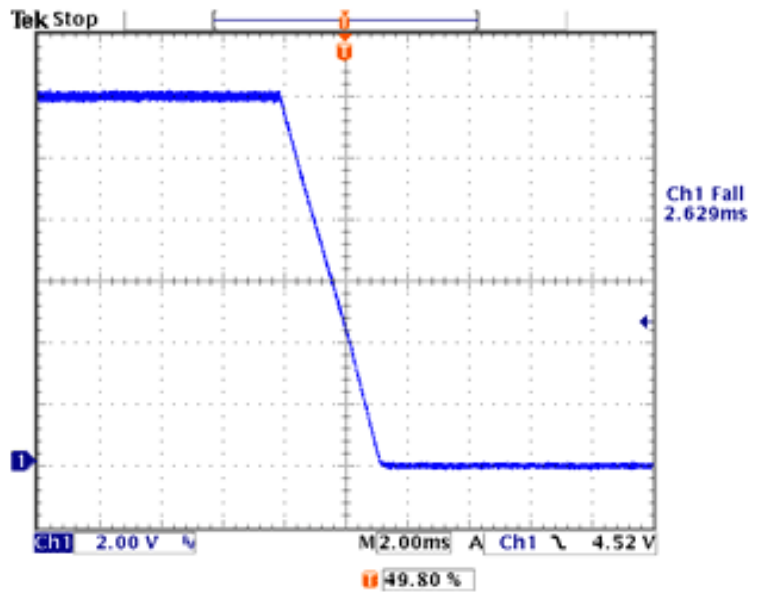

Shutdown at 48V Input, 12V/1A Output

Figure 10. Startup and shutdown.

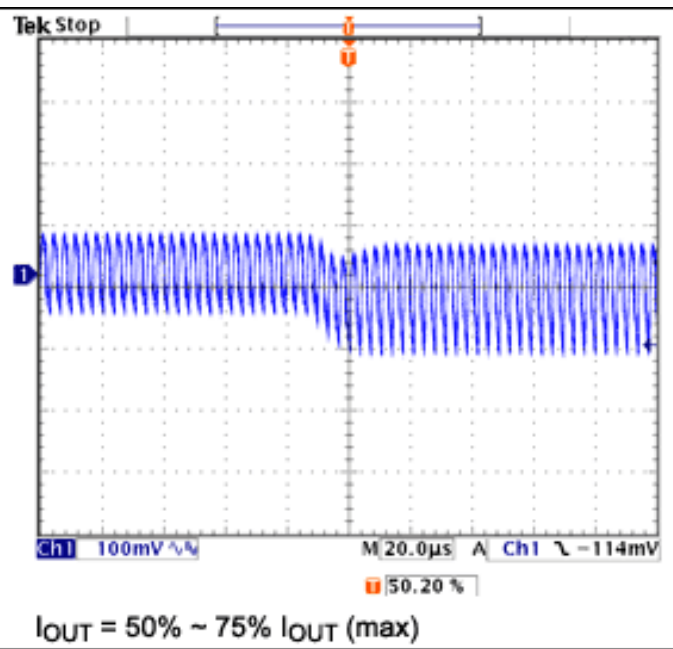
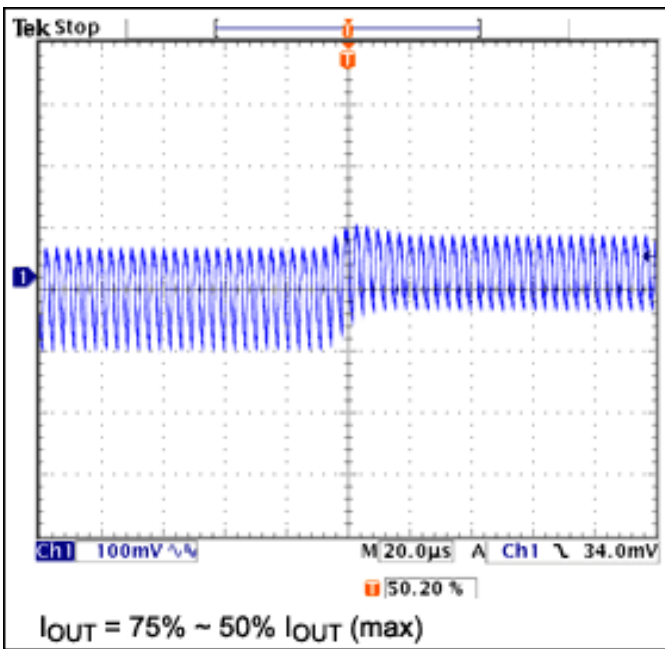

Figure 11. Transient response.

Components List

Table 6. Components List

Designation	Qty	Description
C1, C2, C6, C17	4	10 μ F 25V ceramic capacitor 1206 TDK C3216X5R1E106K MURATA GRM31CR61E106KA12
C3	1	6800pF 100V ceramic capacitor 0603 TDK C1608X7R2A682K
C4	1	100pF 50V ceramic capacitor 0603
C5, C7, C23	3	0.1 μ F 50V ceramic capacitor 0603
C9	1	10 μ F 100V aluminium electrolytic capacitor SANYO 100CE10FS
C10	1	1000pF 1.5kV ceramic capacitor 1808 TDK C4520X7R3D102K
C12, C25	2	0.1 μ F 100V ceramic capacitor 1206 TDK C3216X7R2A104K
C13	1	220 μ F 25V aluminium electrolytic capacitor SANYO 25CE220FSA
C14	1	1000pF 100V ceramic capacitor 0805 TDK C2012X7R2A102K
C19	1	2.2 μ F 10V ceramic capacitor 0603 MURATA GRM188R61A225KE34
C22	1	680pF 50V ceramic capacitor 0603
C28	1	4700pF 50V ceramic capacitor 0603
D1, D2	2	Bridge rectifier DIODES HD01-T
D4, D6	2	Diode 200mA 250V SOD323 DIODES BAV21WS
D5, D13	2	60V Schottky rectifier SMA DIODES B360A
D7	1	SMT LED Lamp 0603 FAIRCHILD QTLP600C-Y
D8	1	Transient voltage suppressor DIODES SMAJ54A
R1	1	20 Ω \pm 1% resistor 0603
R5	1	270m Ω \pm 1% resistor 1206
R9	1	470 Ω \pm 1% resistor 0603
R10	1	10 Ω \pm 1% resistor 1206
R11, R17	2	10k Ω \pm 1% resistor 0603
R12	1	20k Ω \pm 1% resistor 0603
R14	1	25.5k Ω \pm 1% resistor 1206
R15	1	Not used
R16	1	0 Ω \pm 1% resistor 1206
R18	1	1k Ω \pm 1% resistor 0805
R22	1	9.53k Ω \pm 1% resistor 0603
R23	1	2.49k Ω \pm 1% resistor 0603
R24, R31	2	2.5k Ω \pm 1% resistor 0603
R25, R27	2	1k Ω \pm 1% resistor 0603
R26	1	4.75k Ω \pm 1% resistor 0603
R28	1	33k Ω \pm 1% resistor 0805
R30	1	4.7 Ω \pm 1% resistor 0805
Q1	1	MOSFET 150V SO-8 IR IRF7465TR
U2	1	IC Optocoupler NEC PS2801-1-F4-R-A
U3	1	IC V _{REF} 2.5V 0.4% SOT-23 AAC AZ431AN-A

U5	1	PWM controller for PD MAXIM MAX5941BESE
T1	1	Transformer $N_P:N_S:N_B = 35:16:20$ $L_P = 122\mu\text{H}$ GA3271-AL Coilcraft

Transformer Design

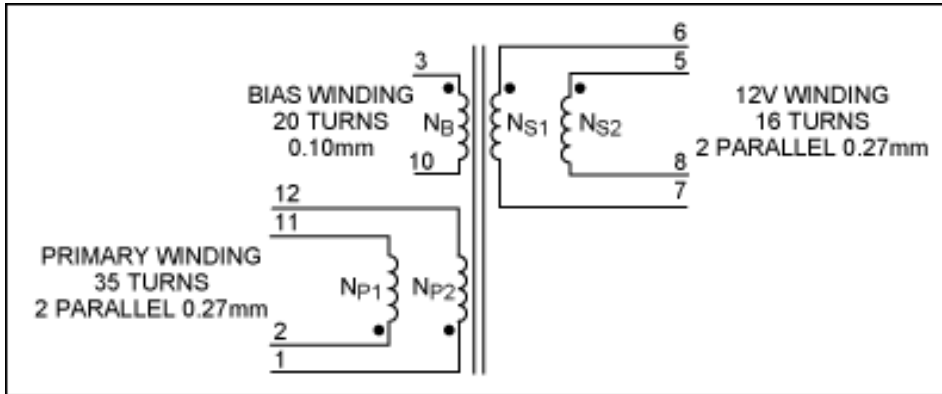

Figure 12. Transformer electrical diagram.

Table 7. Electrical Specifications

Parameter	Conditions	Value
Electrical Strength	50Hz 1 minute, from pins 1–3, 10–12 to pins 5–8	1500V _{RMS}
Primary Inductance	Pins 1, 12; all windings open. Measure at 275kHz	120μH ± 10%
Primary Leakage Inductance	Pins 1, 12; rest of pins shorted. Measure at 275kHz	3μH (max)

Table 8. Materials

Item	Description
1	Core: EFD15, PC40. Manufacturer: TDK
2	Bobbin: EFD15 coil former (SMD), 12 pins
3	Tape: 8.9mm wide insulation tape
4	Magnet wire: 0.25mm diameter with 150°C
5	Magnet wire: 0.27mm diameter with 150°C
6	Magnet wire: 0.10mm diameter with 150°C
7	Varnish
Note	All wires include insulation

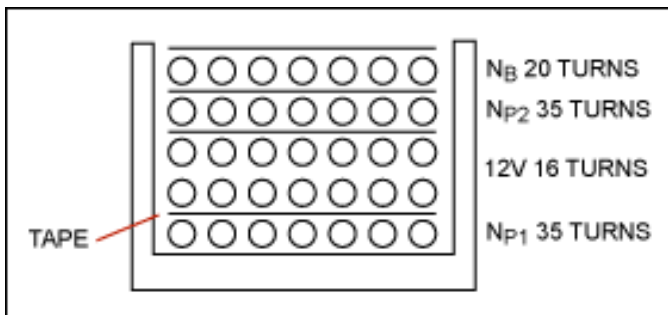

Figure 13. Transformer building diagram.

Table 9. Transformer Construction

Step	Description
Primary N _{P1}	Start at pin 1. Wind 35 turns of item 4 in approximately 1 layer. Finish on Pin 12
Insulation	Use 1 layer of item 3 for insulation
12V Winding	Start at pins 6 and 5. Wind 16 turns of 2 parallel strands of item 5. Finish at pins 7 and 8
Insulation	Use 1 layer of item 3 for safety insulation
Primary N _{P2}	Start at pin 2. Wind 35 turns of item 4 in approximately 1 layer. Finish on pin 11
Insulation	Use one layer of item 3 for safety insulation
Bias Winding	Start at pin 3. Wind 20 turns of item 6. Spread turns evenly across bobbin. Finish at pin 10
Outer Wrap	Wrap windings with 2 layers of item 3
Final Assembly	Assemble and secure core halves. Varnish impregnate with item 9

IEEE is a registered service mark of the Institute of Electrical and Electronics Engineers.

Application Note 4162: www.maxim-ic.com/an4162

More Information

For technical support: www.maxim-ic.com/support

For samples: www.maxim-ic.com/samples

Other questions and comments: www.maxim-ic.com/contact

Automatic Updates

Would you like to be automatically notified when new application notes are published in your areas of interest? [Sign up for EE-Mail™](#).

Related Parts

MAX5941B: [QuickView](#) -- [Full \(PDF\) Data Sheet](#) -- [Free Samples](#)

AN4162, AN 4162, APP4162, Appnote4162, Appnote 4162

Copyright © by Maxim Integrated Products

Additional legal notices: www.maxim-ic.com/legal