

APPLICATION NOTE 4156

Reference Design for an 802.11b/g RF Front-End Module Using the MAX2830

Abstract: This module uses the highly integrated MAX2830 RF transceiver. It is a complete RF front-end solution that meets the WLAN IEEESM 802.11b/g standard. The transmitter can deliver more than 15dBm Tx power at EVM < 5.6% with a 54Mbps OFDM 802.11g signal. The receiver can provide an IQ signal EVM < 9% with a -74.5dBm 54Mbps OFDM 802.11g signal.

More Information

- [Wireless Home](#)
- [Application Notes and Tutorials](#)
- [EV Kit Software](#)
- [Technical Support](#)

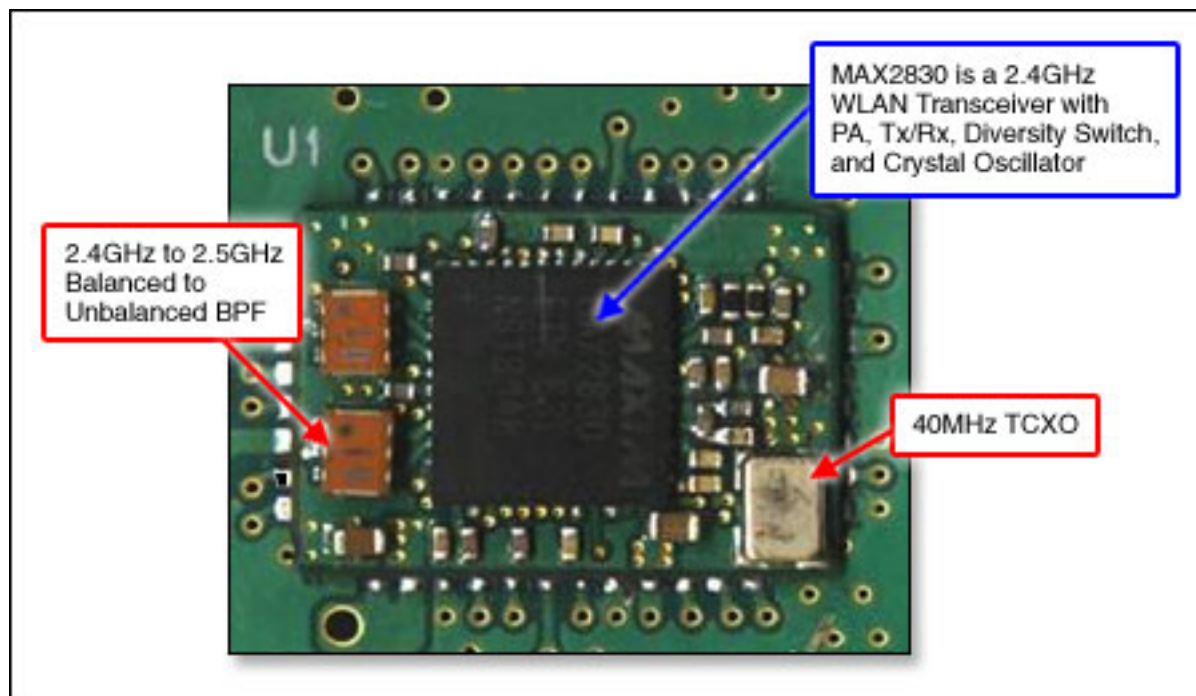

Figure 1. The reference design board shows the MAX2830 in an 802.11b/g RF front-end module.

Important Design Features

- Cascaded Receive Noise Figure of 6dB
- Low Phase Noise of -95dBc/Hz at 10kHz Offset
- Rx EVM < 9% at -74.5dBm with an 802.11g 54Mbps OFDM Signal
- 95dB Receive Gain Control Range (32dB RF and 63dB BB VGA)
- Tx EVM < 5.6% at 15dBm Output Power with an 802.11g 54Mbps OFDM Signal
- 25dB Transmit Gain Control Range
- Supports Full-Range 802.11b/g Data Rates
- Small 11mm x 16mm Size
- Low BOM Cost

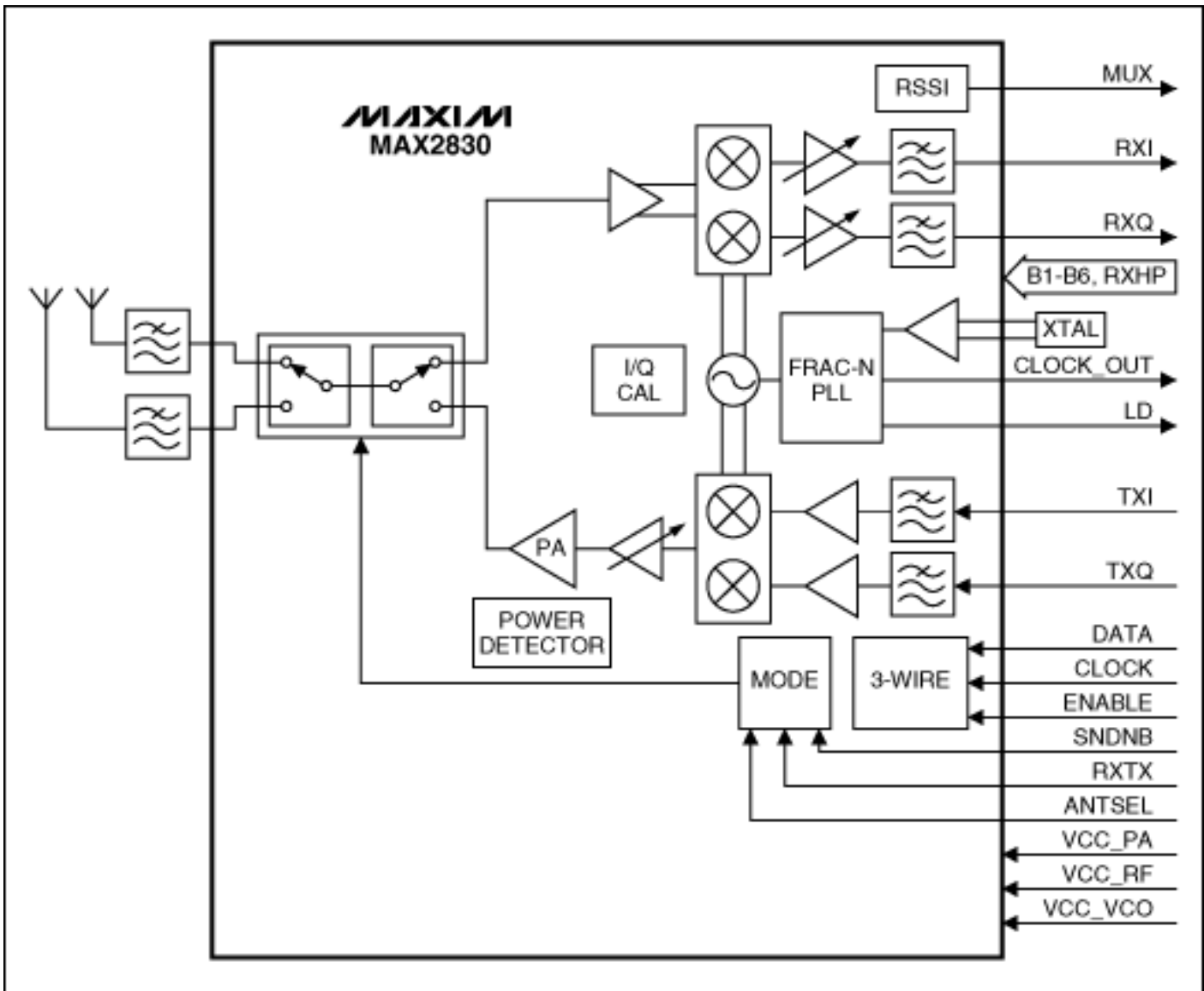

Figure 2. Block diagram for the 802.11 b/g RF module.

Lab Measurements

DC Performance

$V_{BATT} = +3.3V$, $V_{CC} = +2.85V$, $T_A = +25^\circ C$

Parameter	Test Condition	Meas.	Unit
Shutdown Supply Current		10	μA
Standby Supply Current	PLL, VCO, LO Generator ON	28	mA
Receive Supply Current		65	mA
Transmit Supply Current	$P_{OUT} = 15dBm$	289	mA

Receive Summary

$V_{BATT} = +3.3V$, $V_{CC} = +2.85V$, $f_{RF} = 2437MHz$, RF input = 802.11a, 64QAM, 54Mbps at antenna, $V_{OUT} = 112mV_{RMS}$ at RXI and RXQ baseband outputs, $RXHP = 0$, $T_A = +25^\circ C$

Parameter	Test Condition	Meas.	Unit
Frequency Range		2.4 to 2.5	GHz
Receive EVM	Max Gain, VGA adjusted for $V_{OUT} = 112mV_{RMS}$, $P_{IN} = -65dBm$	3.9	%
	Mid Gain, VGA adjusted for $V_{OUT} = 112mV_{RMS}$, $P_{IN} = -45dBm$	2.5	
	Min Gain, VGA adjusted for $V_{OUT} = 112mV_{RMS}$, $P_{IN} = -10dBm$	2.7	
Sensitivity	Receive EVM = 9%	Antenna 1	-73
		Antenna 2	-74.5

Transmit Summary

$V_{BATT} = +3.3V$, $V_{CC} = +2.85V$, $f_{RF} = 2437MHz$, baseband inputs = $110mV_{RMS}$, 802.11a, 64QAM, 54Mbps, Tx output measured at Antenna 1, RXHP = 0, $T_A = +25^{\circ}C$

Parameter	Test Condition	Meas.	Unit
Maximum Transmit Output	Tx VGA adjusted for EVM = 5.6%, Tx VGA = -4dB	15	dBm
ACPR	Tx VGA set for EVM < 5.6%, channel BW = 20MHz	$f_{OFFSET} = 20MHz$	36
		$f_{OFFSET} = 40MHz$	55
		$f_{OFFSET} = 60MHz$	60

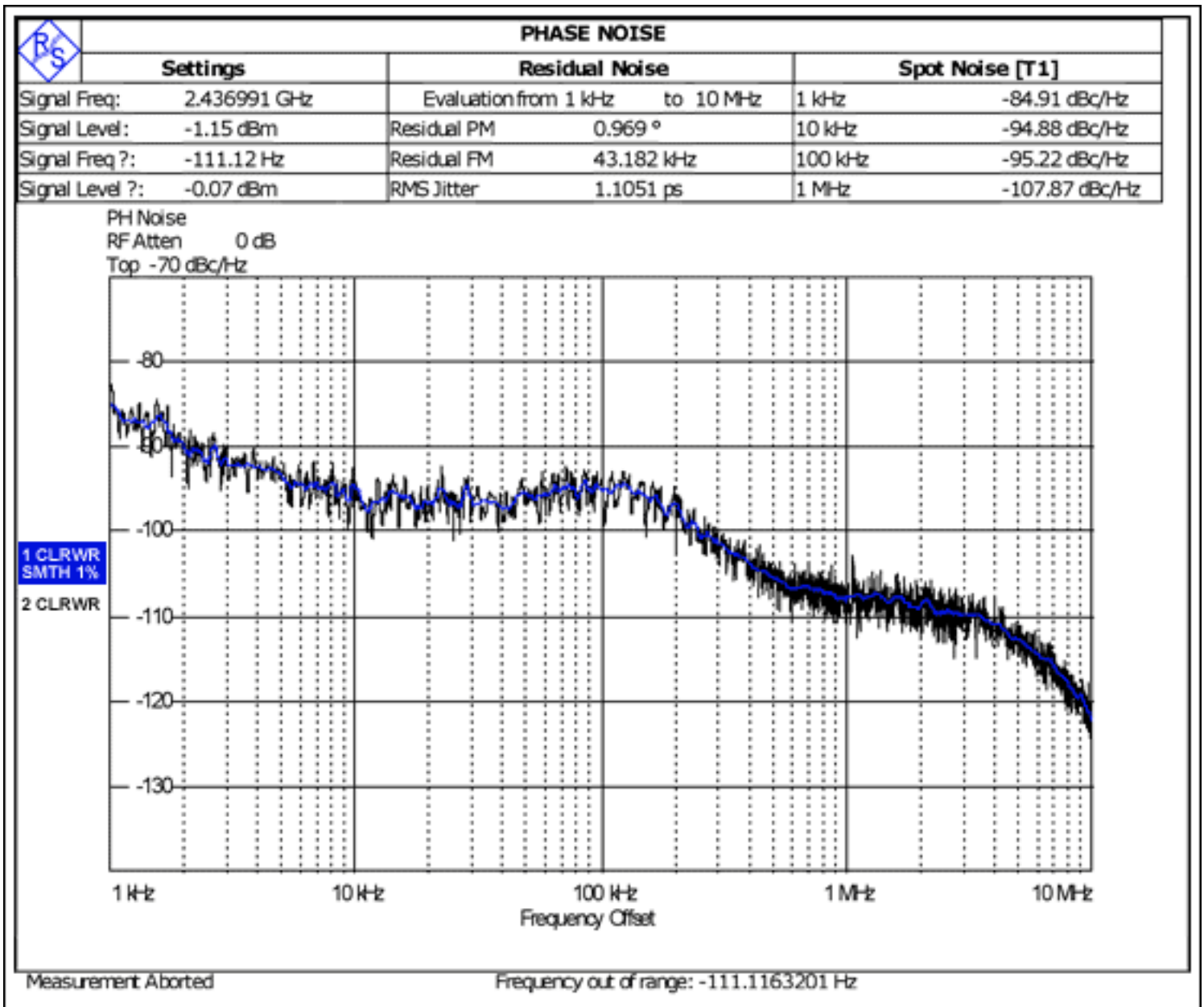

Figure 3. Phase noise plot of the reference design.

Detailed Description

The MAX2830 is a single-chip, single-band, Dual Mode™ direct-convert transceiver designed for a 2.4GHz 802.11b/g (OFDM and CCK) WLAN application. The device integrates all the circuitry required to implement the complete RF transceiver function: PA, T/R switch, antenna diversity switch, LNA, 50Ω matching components, sigma-delta fractional synthesizer, crystal oscillator, and unique I/Q amplitude and phase-error calibration circuits. The device also eliminates the need for external SAW filters by implementing on-chip monolithic filters for both receiver and transmitter. The baseband Tx and Rx filters are optimized to meet the 802.11g IEEE standard. With an additional RF filter and several passive components, one can form a complete 802.11b/g WLAN RF front-end solution that delivers high performance within a small form factor and low price.

Application Note Links

Application note 3630, "[Power Supply and Ground Design for a WiFi Transceiver](#)"

Dual Mode is a trademark of Maxim Integrated Products, Inc.

IEEE is a service mark of the Institute of Electrical and Electronics Engineers.

Application Note 4156: www.maxim-ic.com/an4156

More Information

For technical support: www.maxim-ic.com/support

For samples: www.maxim-ic.com/samples

Other questions and comments: www.maxim-ic.com/contact

Automatic Updates

Would you like to be automatically notified when new application notes are published in your areas of interest?

[Sign up for EE-Mail.](#)

Related Parts

MAX2830: [QuickView](#)

AN4156, AN 4156, APP4156, Appnote4156, Appnote 4156

Copyright © by Maxim Integrated Products

Additional legal notices: www.maxim-ic.com/legal