

APPLICATION NOTE 4151

Using the MAX15005 Supply and Driver for an LED Application

Abstract: This reference design is a complete application design for an automotive LED application. It utilizes the MAX15005 current-mode controller to boost a standard lead-acid car battery to 21V for driving a string of automotive LEDs.

The reference design below provides a reference design for an automotive LED application. The MAX15005 is used to boost a standard, 8V to 16V car battery to 21V in order to drive a string of 6 to 8 LEDs.

Key specifications for this reference design are listed below, along with a detailed schematic (**Figure 1**) and the bill of materials (**Table 1**) needed for this application.

Specifications

- V_{IN} : 8V to 16V (Continuous), 40V (Transient)
- V_{LED+} Supply Voltage: 21V \pm 5% at 80mA (max)
- V_{LED+} Load Range: 10V to 20V at 70mA
- I_{LED} : 70mA \pm 5%
- Dimming Input: 400Hz, 50 Ω , Open Collector
- Dimming Resolution: 3 μ s
- Switching Frequency: 385kHz
- Operating Temperature: -40 $^{\circ}$ C to +125 $^{\circ}$ C

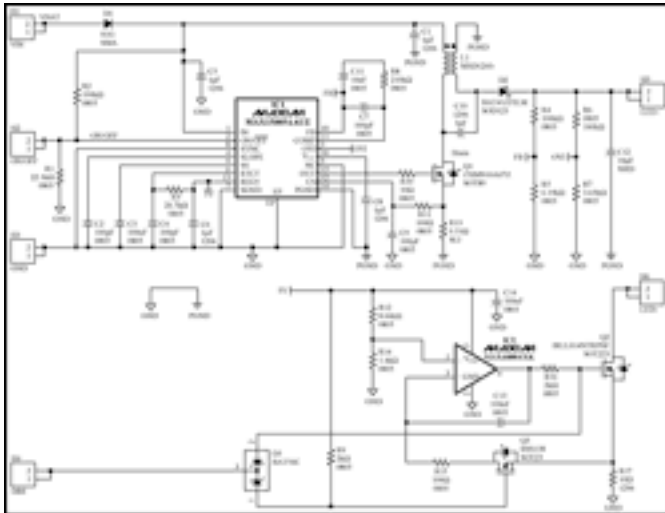

[More detailed image](#) (PDF, 92kB)

Figure 1. MAX15005 reference design.

Table 1. Bill of Materials

Designator	Value	Description	Part	Footprint	Manufacturer	Quantity
C1, C5, C6, C8, C10	1 μ F/50V	Capacitors	GCM31MR71H105KA55L	1206	Murata	5
C2	200pF/100V	Capacitor	GRM2165C2A201JA01D	0805	Murata	1
C3, C13, C14	100nF/100V	Capacitors	GCM21BR72A104KA37L	0805	Murata	3
C4, C7, C9	100pF/50V	Capacitors	GRM2165C1H101JA01D	0805	Murata	3
C11	10nF/50V	Capacitor	GRM216R71H103KA01D	0805	Murata	1
C12	10 μ F/50V	Capacitor	UUD1H100MCL1GS	SMD	Nichicon	1
D1	1A/400V	Diode	S1G	SMA	Fairchild	1
D2	200mA/100V	Schottky diode	BAT41ZFILM	SOD123	STM	1
D3	200mA/30V	Schottky diode	STM	SOT23	STM	1
L1	470 μ F/0.86A	Inductor	MSD1260-474	SMD	Coilcraft	1
Q1	1A/100V	n-FET	ZXMN10A07Z	SOT89	Zetex	1
Q2	2A/55V	n-FET	IRLL014NTRPBF	SOT223	International Rectifier	1
Q3	220mA/50V	n-FET	BSS138	SOT23	Fairchild	1
R1	22.1k Ω	Resistor	SMD, 1%, 0.125W	0805	Vishay	1
R2, R4, R6	100k Ω	Resistors	SMD, 1%, 0.125W	0805	Vishay	3
R3	26.7k Ω	Resistor	SMD, 1%, 0.125W	0805	Vishay	1
R5	6.19k Ω	Resistor	SMD, 1%, 0.125W	0805	Vishay	1
R7	3.65k Ω	Resistor	SMD, 1%, 0.125W	0805	Vishay	1
R8	210k Ω	Resistor	SMD, 1%, 0.125W	0805	Vishay	1
R9, R16	2k Ω	Resistors	SMD, 1%, 0.125W	0805	Vishay	2
R10	10 Ω	Resistor	SMD, 1%, 0.125W	0805	Vishay	1
R11	100 Ω	Resistor	SMD, 1%, 0.125W	0805	Vishay	1
R12	8.66k Ω	Resistor	SMD, 1%, 0.125W	0805	Vishay	1
R13	0.51 Ω	Resistor	Sense resistor	SL1	Vishay	1
R14	1.4k Ω	Resistor	SMD, 1%, 0.125W	0805	Vishay	1
R15	100 Ω	Resistor	SMD, 1%, 0.125W	0805	Vishay	1
R17	10 Ω	Resistor	SMD, 1%, 0.205W	1206	Vishay	1
IC1	MAX15005A	Boost controller	MAX15005AAUE+	16-TSSOP-EP	Maxim	1
IC2	MAX4400	Single op-amp	MAX4400AXK+	5-SC70	Maxim	1

The oscilloscope photos in **Figures 2, 3, and 4** show the switching waveforms for this reference design at three different dimming conditions.

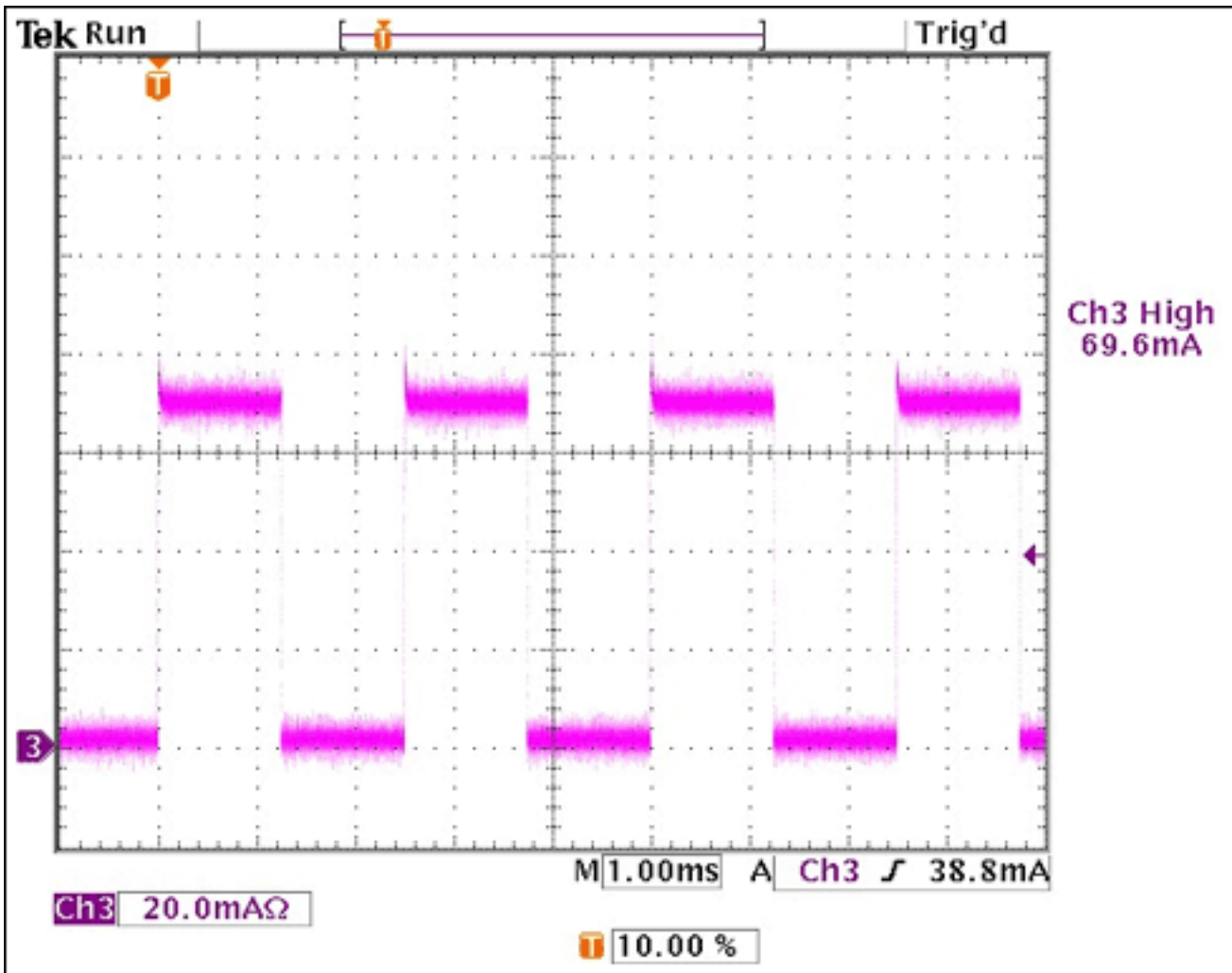

Figure 2. Waveform measurements for I_{LED} at $V_{IN} = 14V$ with dimming at 50.0%.

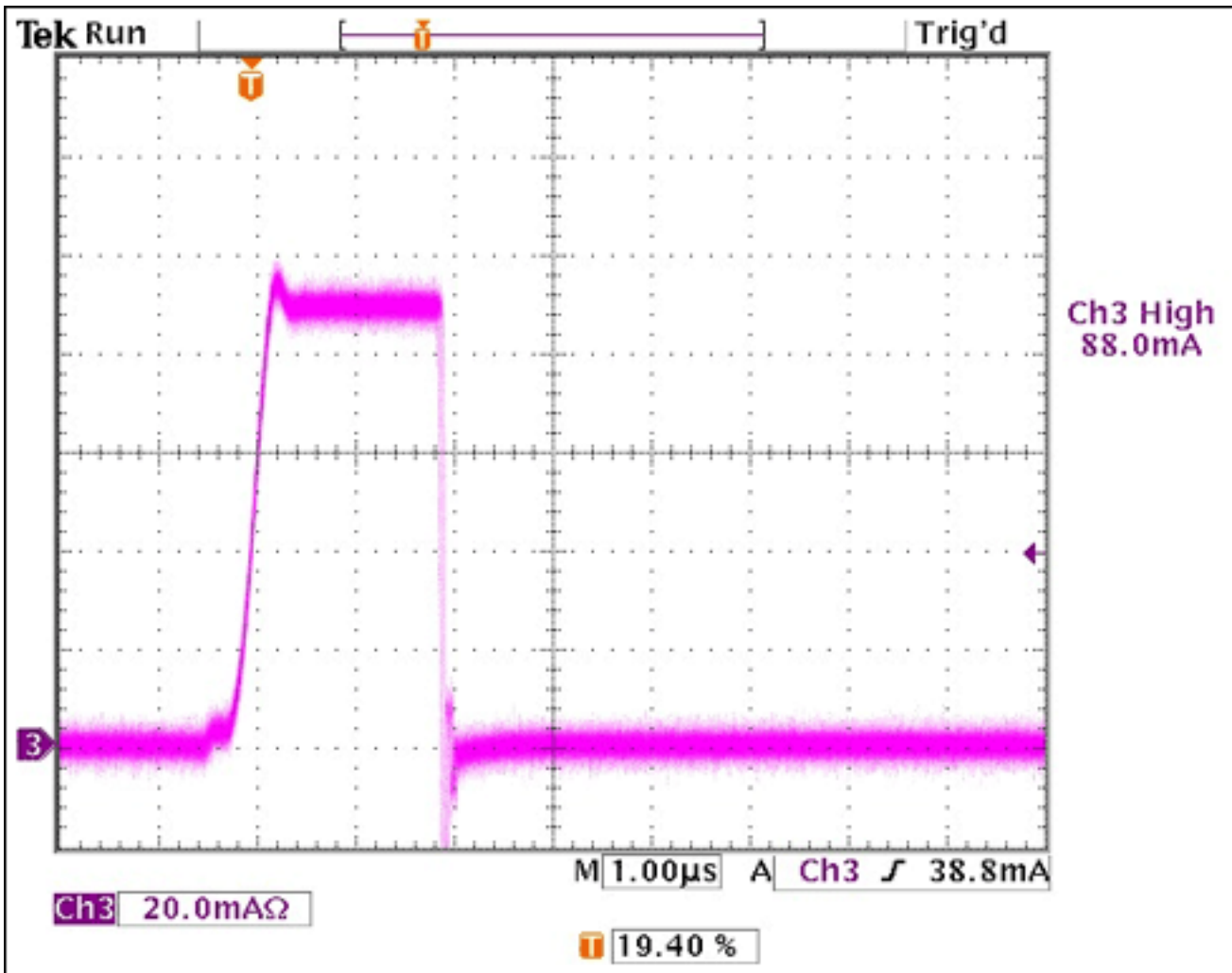

Figure 3. Waveform measurements for I_{LED} at $V_{IN} = 14V$ with dimming at 0.1%.

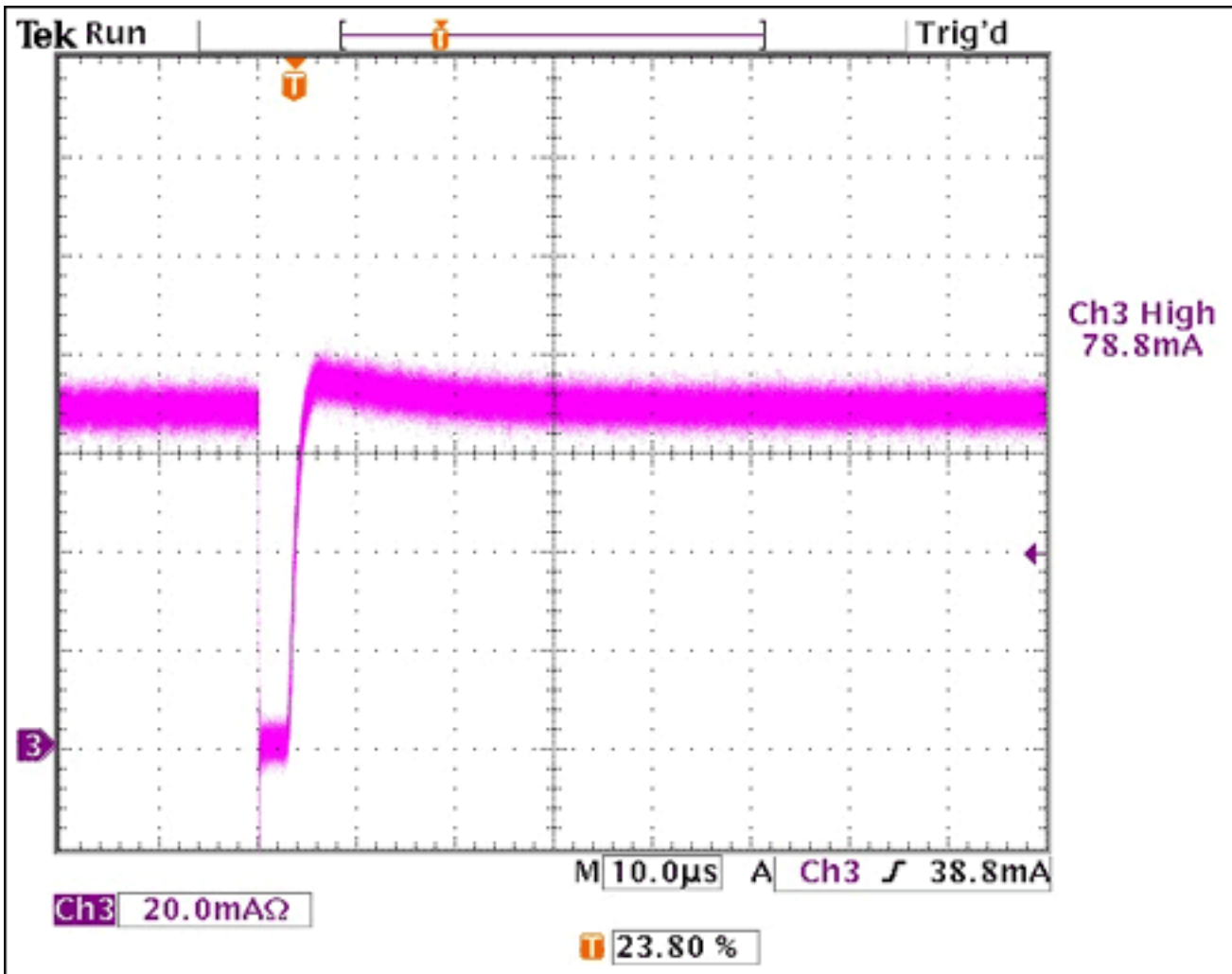

Figure 4. Waveform measurements for I_{LED} at $V_{IN} = 14V$ with dimming at 99.9%.

Application Note 4151: www.maxim-ic.com/an4151

More Information

For technical questions and support: www.maxim-ic.com/support

For samples: www.maxim-ic.com/samples

Other questions and comments: www.maxim-ic.com/contact

Keep Me Informed

Preview new application notes in your areas of interest as soon as they are published. Subscribe to [EE-Mail - Application Notes](#) for weekly updates.

AN4151, AN 4151, APP4151, Appnote4151, Appnote 4151

Copyright © by Maxim Integrated Products

Additional legal notices: www.maxim-ic.com/legal