

APPLICATION NOTE 4150

Reference Design Using the MAX5066 for a High Performance Application

Abstract: The MAX5066 high performance dual buck regulator provides outstanding performance. The reference design in this application note depicts a detailed solution with complete schematic, bill of materials, and load-transient-response scope photos.

In many networking and telecom applications, there are multiple regulated power rails. Many of these power rails need to provide high current, reasonable size and efficiency, and outstanding load-transient response. This article shows a detailed reference design solution using the MAX5060 dual buck controller operating at a switching frequency of 300kHz.

Key specifications for this reference design are listed below, along with a detailed schematic (**Figure 1**) and the bill of materials (**Table 1**) needed for this application.

Specifications

- $V_{IN} = 5.15V (-0.4V, +0.4V)$
- $V_{OUT1} = 1.2V \pm 48mV / I_{OUT1} = 0 \text{ to } 8.5A$ (Including Transients)
- Converter 1 Output-Voltage Ripple: $12mV_{P-P}$
- Converter 1 Load-Transient Response: $18mV_{P-P}$ for 10% to 60% Variation of the Load
- $V_{OUT2} = 3.3V \pm 132mV / I_{OUT2} = 0 \text{ to } 4.4A$ (Including Transients)
- Converter 2 Output-Voltage Ripple: $27mV_{P-P}$
- Converter 2 Load-Transient Response: $40mV_{P-P}$ for 10% to 60% Variation of the Load
- Composite Efficiency of Converters 1 and 2: 93.38% at Full Load
- Temperature Range: $-40^{\circ}C$ to $+85^{\circ}C$

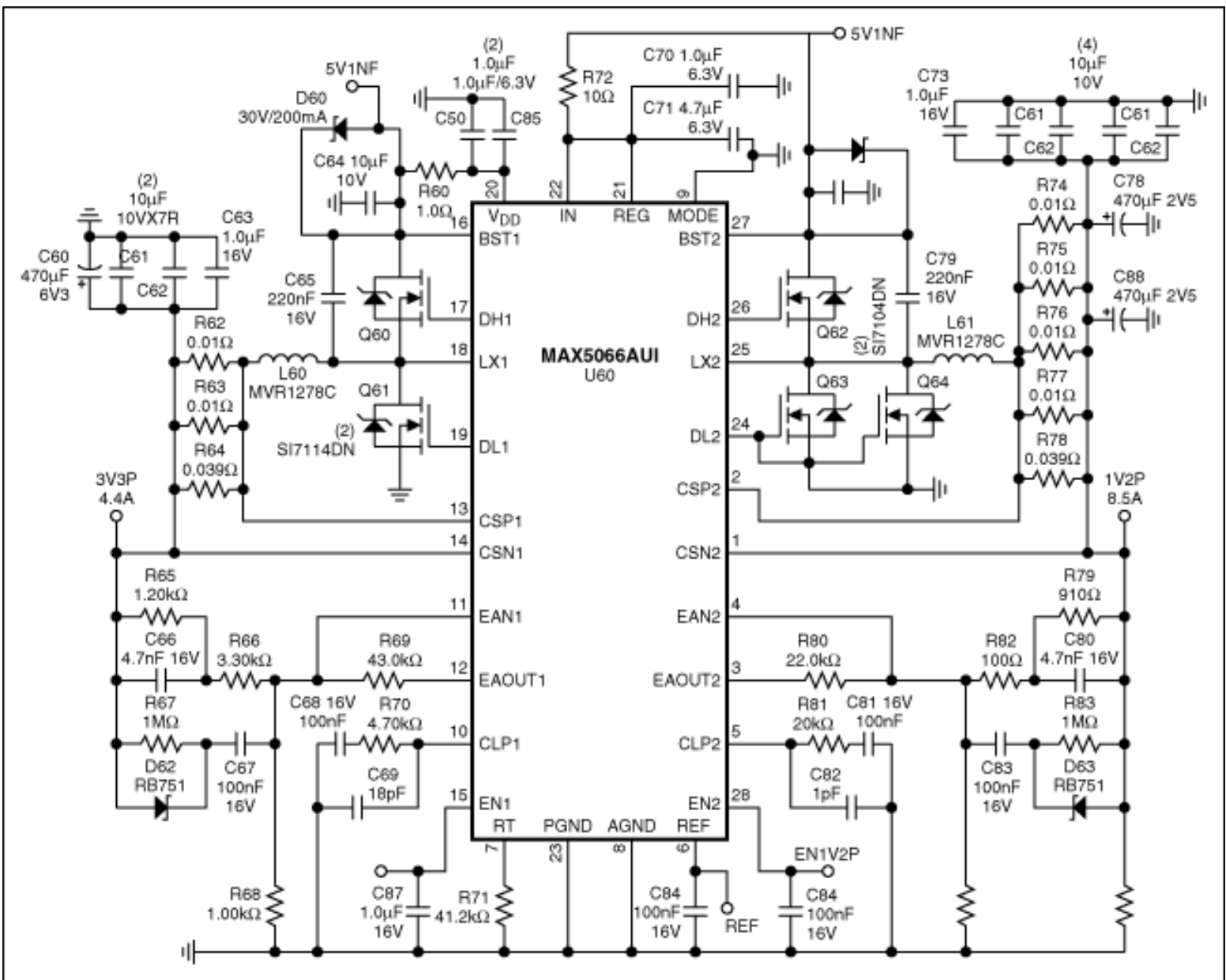

Figure 1. MAX5066 reference design showing DC-DC converters of 1.2V/8.5A and 3.3V/4.4A from 5.1V; $f_{sw} = 295\text{kHz}$.

Table 1. Bill of Materials

Designator	Value	Description	Part	Footprint	Manufacturer	Quantity
C50, C71	4.7 μ F/6.3V	Capacitors	JMK107BJ475MA-T	0603	Taiyo Yuden	2
C60	470 μ F/6.3V	Capacitor	APXA6R3ARA471MHC0G	3.1mm x 4.2mm x 2.2mm	Nippon Chemi-Con	1
C61, C62, C64, C72, C74, C75, C76, C77	10 μ F/10V	Capacitors	LMK212BJ106M	0805	Taiyo Yuden	8
C63, C73, C86, C87	1.0 μ F/16V	Capacitors	EMK107BJ105KA-T	0603	Taiyo Yuden	4
C65, C79	220nF/16V	Capacitors	EMK107BJ224MA-T	0603	Taiyo Yuden	2
C66, C80	4.7nF/16V	Capacitors	TMK105BJ472KV-F	0402	Taiyo Yuden	2
C67, C68, C81, C83, C84	100nF/16V	Capacitors	EMK105BJ104KV-FR	0402	Taiyo Yuden	5
C69	18pF	Capacitor	UMK105CH180JW	0402	Taiyo Yuden	1
C70, C85	1.0 μ F/6.3V	Capacitors	JMK105BJ105KV	0402	Taiyo Yuden	2
C78, C88	470 μ F/2.5V	Capacitors	APXE2R5ARA471MF80G	1.9mm x 3.5mm x 1.6mm	Nippon Chemi-Con	2
C82	OPEN	Capacitor	OPEN	0402	OPEN	1
L60, L61	2.3 μ H	Inductors	MVR1278	7.8mm x 11.5mm	Coilcraft	2
Q60, Q61	n-channel 30V	nMOSFETs	SI7114DN	PowerPAK 1212-8	Vishay-Siliconix	2
Q62, Q63, Q64	n-channel 20V	nMOSFETs	SI7106DN	PowerPAK 1212-8	Vishay-Siliconix	3
R60, R72	1 Ω	Resistors	SMD, 1%, 63mW	0402	Vishay	2
R62, R63, R74, R75, R76, R77	0.01 Ω	Resistors	RL1220T, 250mW	0805	Susumu	6
R64	0.039 Ω	Resistor	RL1220T, 250mW	0805	Susumu	1
R65	1.2k Ω	Resistor	SMD, 1%, 63mW	0402	Vishay	1
R66	3.3k Ω	Resistor	SMD, 1%, 63mW	0402	Vishay	1
R67, R83	1M Ω	Resistors	SMD, 1%, 63mW	0402	Vishay	2
R68, R84, R85	1k Ω	Resistors	SMD, 1%, 63mW	0402	Vishay	3
R69	43k Ω	Resistor	SMD, 1%, 63mW	0402	Vishay	1
R70	4.7k Ω	Resistor	SMD, 1%, 63mW	0402	Vishay	1
R71	41.2 Ω	Resistor	SMD, 1%, 63mW	0402	Vishay	1
R78	0.027 Ω	Resistor	RL1220T, 250mW	0805	Susumu	1
R79	910 Ω	Resistor	SMD, 1%, 63mW	0402	Vishay	1
R80	22k Ω	Resistor	SMD, 1%, 63mW	0402	Vishay	1
R81	20k Ω	Resistor	SMD, 1%, 63mW	0402	Vishay	1
R82	100 Ω	Resistor	SMD, 1%, 63mW	0402	Vishay	1
D60, D61	30V/200mA	Schottky diodes	RB521S30T1	SOD-523	ON Semiconductor	2
D62, D63	30V/30mA	Schottky diodes	RB751	SOD-523	ON Semiconductor	2
U60	MAX5066	PWM controller	MAX5066AUI	28-TSSOP-EP	Maxim	1

Efficiency data for each regulator is summarized in **Table 2**, showing high efficiency for both outputs, as shown in **Figure 2**.

Table 2. Efficiency Data

V_{IN} (V)	I_{IN} (A)	V_{OUT1} (V)	I_{OUT1} (A)	V_{OUT2} (V)	I_{OUT2} (A)	Efficiency (%)
5.1402	5.0780	1.1814	8.5008	3.2558	4.4016	93.38%
5.1347	4.5728	1.1853	7.6491	3.2636	3.9652	93.73%
5.1361	4.0605	1.1891	6.8012	3.2713	3.5244	94.06%
5.1500	3.5440	1.1928	5.9558	3.2791	3.0836	94.32%
5.1441	3.0423	1.1967	5.1030	3.2870	2.6435	94.54%
5.1497	2.5398	1.2005	4.2507	3.2948	2.2086	94.65%
5.1522	2.0337	1.2044	3.3988	3.3030	1.7608	94.57%
5.1490	1.5407	1.2083	2.5557	3.3111	1.3232	94.15%
5.1465	1.0441	1.2122	1.7073	3.3194	0.8815	92.97%
5.1380	0.5472	1.2163	0.8455	3.3279	0.4419	88.88%

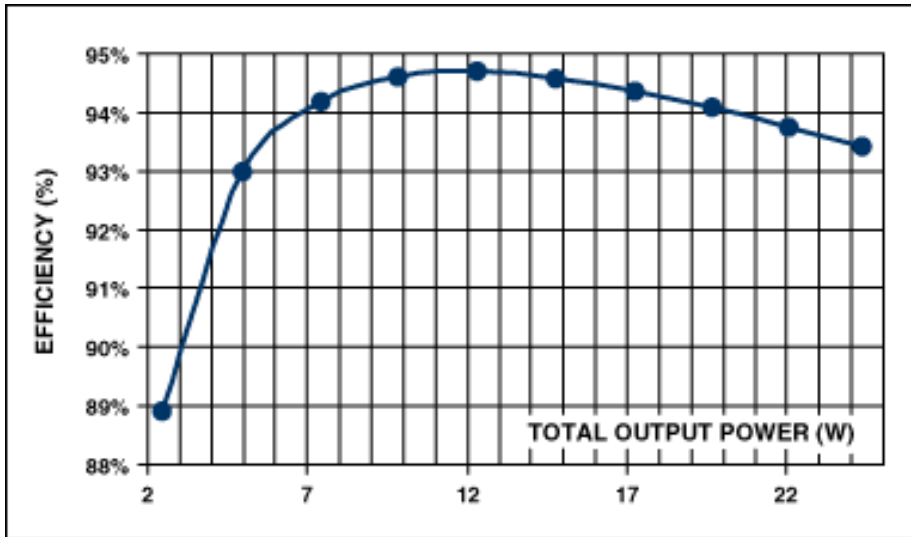

Figure 2. Global efficiency is shown as a function of total output power.

In **Figures 3 and 4**, the output voltages of the controllers are shown versus their output load currents.

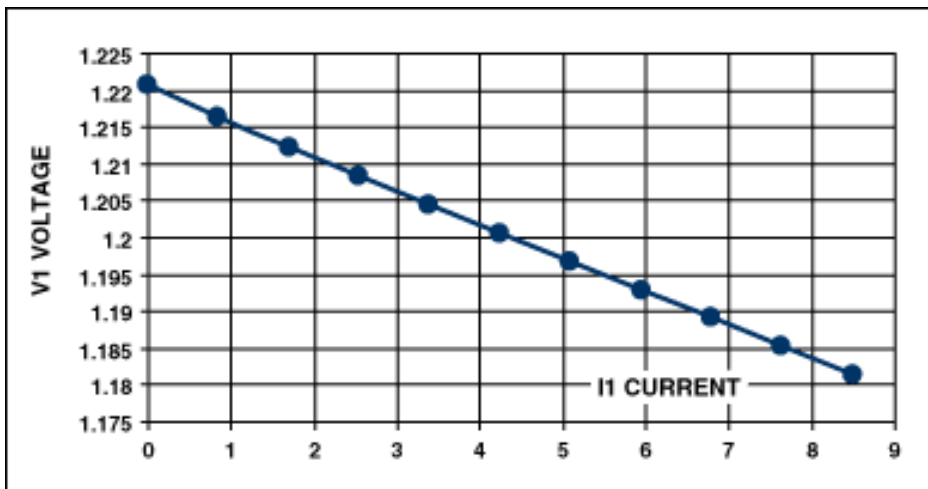

Figure 3. The first controller's output voltage versus its output load current.

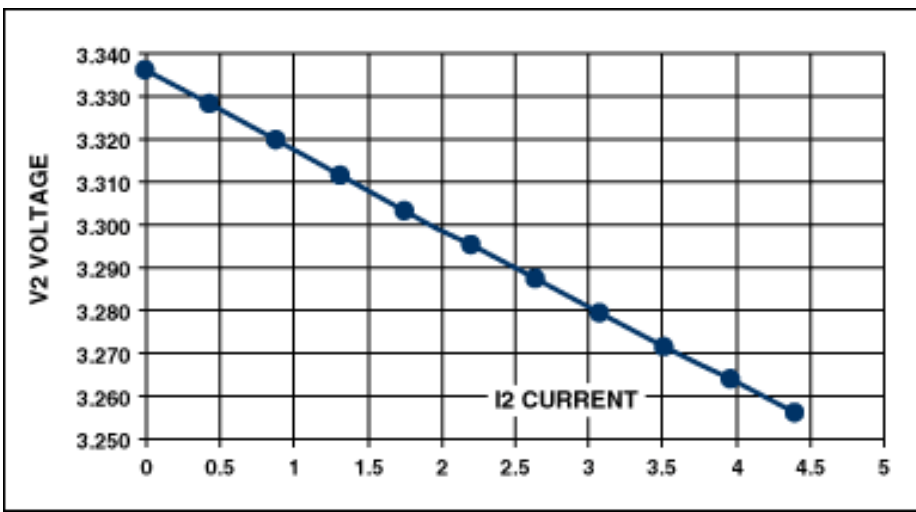

Figure 4. The second controller's output voltage versus its output load current.

Load-transient-response performance for each regulated output is shown in **Figures 5 and 6**.

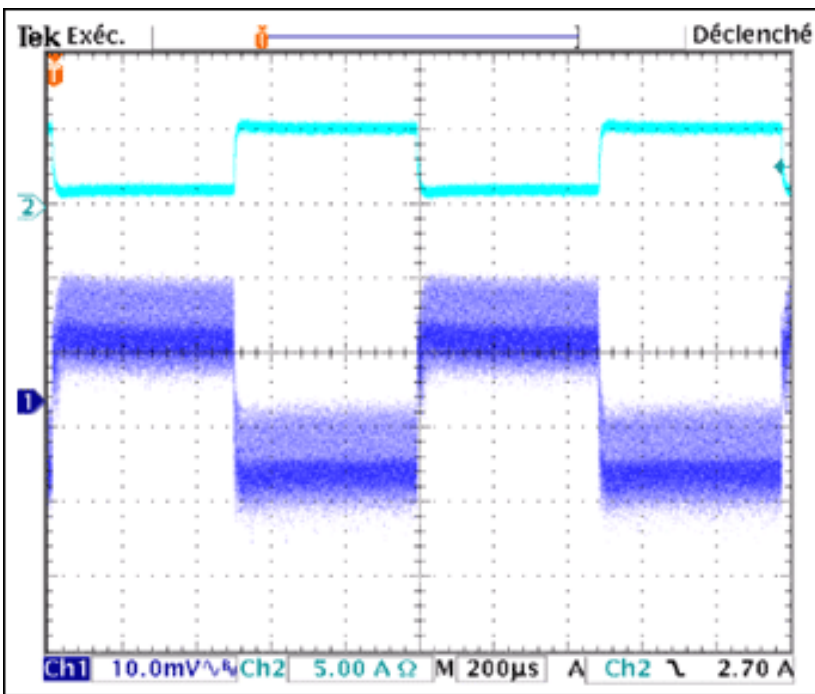

Figure 5. A transient of 1.2V with a load varying between 0.85A and 5.1A in 18mV steps over a period of 10μs.

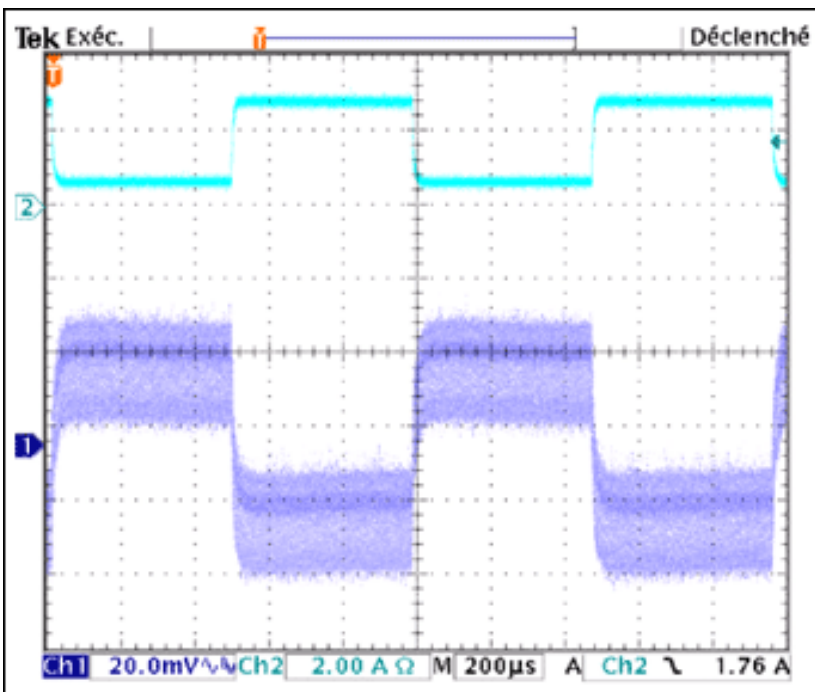

Figure 6. A transient of 3.3V with a load varying between 0.44A and 2.64A in 40mV steps over a period of 10µs.

Application Note 4150: www.maxim-ic.com/an4150

More Information

For technical questions and support: www.maxim-ic.com/support

For samples: www.maxim-ic.com/samples

Other questions and comments: www.maxim-ic.com/contact

Keep Me Informed

Preview new application notes in your areas of interest as soon as they are published. Subscribe to [EE-Mail - Application Notes](#) for weekly updates.

Related Parts

MAX5066: [QuickView](#) -- [Full \(PDF\) Data Sheet](#) -- [Free Samples](#)

AN4150, AN 4150, APP4150, Appnote4150, Appnote 4150

Copyright © by Maxim Integrated Products

Additional legal notices: www.maxim-ic.com/legal