

APPLICATION NOTE 414

Solar Cells and Switching Regular Charge Batteries at Optimum Rates

Abstract: This design idea shows how a switching converter regulates its input voltage and enables solar cells to charge batteries at optimum rates. The DC-DC step-down regulator, MAX639, and solar cells minimize battery charging time by regulating and maintaining solar battery voltage at a level necessary for maximum power transfer.

A battery of solar cells can charge a battery of NiCd cells with better than 80% efficiency, provided the solar battery voltage exceeds the fully charged NiCd output by one diode drop. For that case, a simple reverse-blocking diode provides the charging path between the two batteries. Through inflexible, such dedicated systems are simple and effective.

But the simple approach is impractical if adjustment of the charge voltage is impossible or inconvenient. Badly mismatched voltages (>>one diode drop) cause a low level of power transfer and consequent slow charging of the NiCd cells. (Current from a solar cell is relatively constant with cell voltage, producing output power that rises linearly and peaks near the cell's open-circuit voltage (Figure 1).) You can speed the charging rate by adding more solar cells in parallel, but that alternative is expensive.

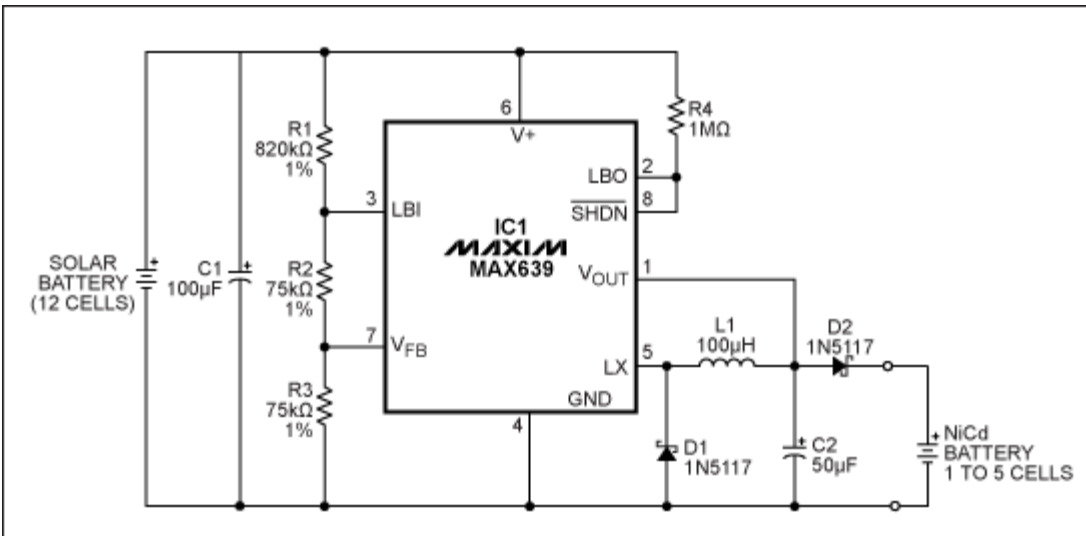

Figure 1. The I-V curve for a solar battery (top) shows that peak power output occurs near the cell's open-circuit voltage. (The battery consists of 12 amorphous-silicon cells, with an area of 11.5in².)

Adding a step-down switching regulator, on the other hand, enables a given bank of solar cells to charge batteries of various terminal voltages, at optimum rates and with efficiencies approximating that of the regulator itself (Figure 2). The IC must operate in an unorthodox fashion, regulating the flow of charge current such that the solar battery's voltage remains near the level required for peak power transfer.

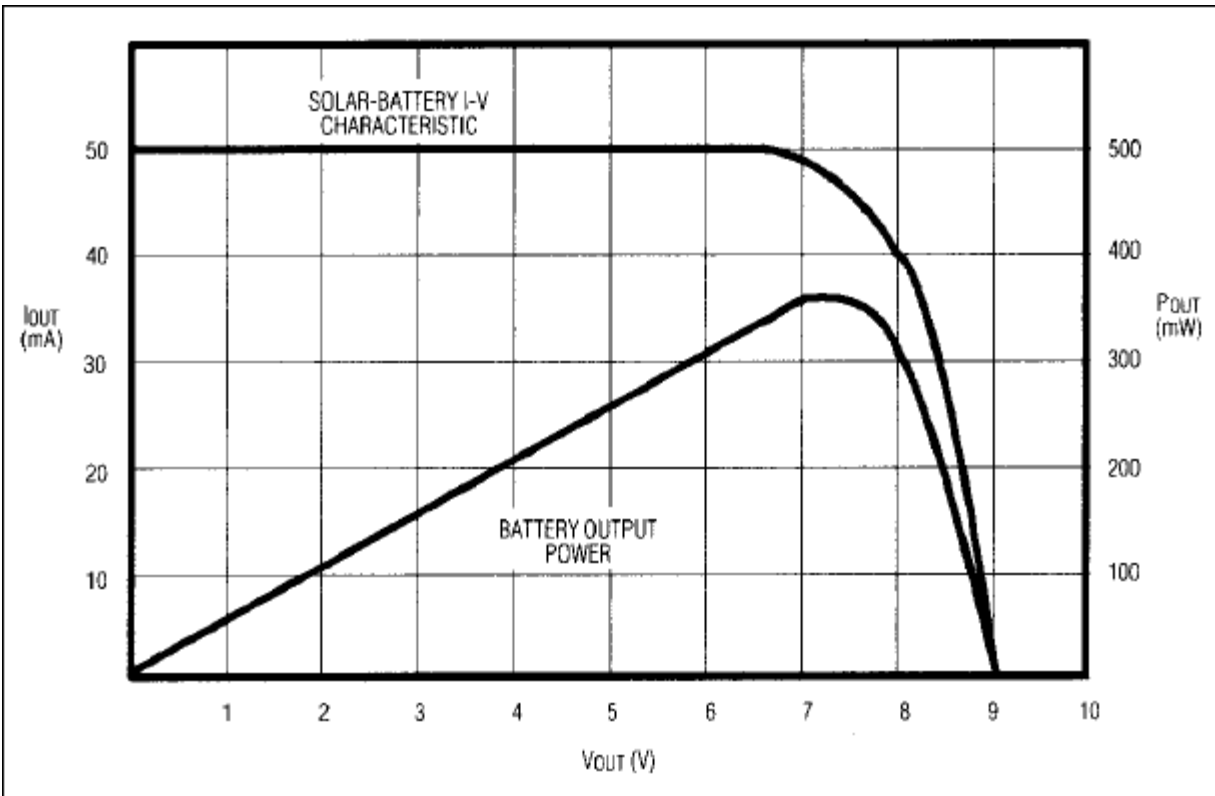

Figure 2. This circuit minimizes NiCd charging time by regulating the solar battery voltage, maintaining it at the level necessary for maximum power transfer.

The device therefore regulates its input voltage, rather than its output voltage as is customary. Divider R2/R3 disables the internal regulating loop by holding V_{FB} low, and divider R1/(R2 + R3) enables LBI (low battery input) to sense a decrease in the solar-battery voltage. Such decreases, which represent a move away from the solar cells' peak power output, cause LBO to pull active-low SHDN low and disable the chip. LBI then senses a rising input voltage, LBO goes high, and the resulting "bang-bang" control maintains maximum power transfer to the NiCd cells (Figure 3). Current limiting in the IC produces the 200mA ceiling for I_{OUT} .

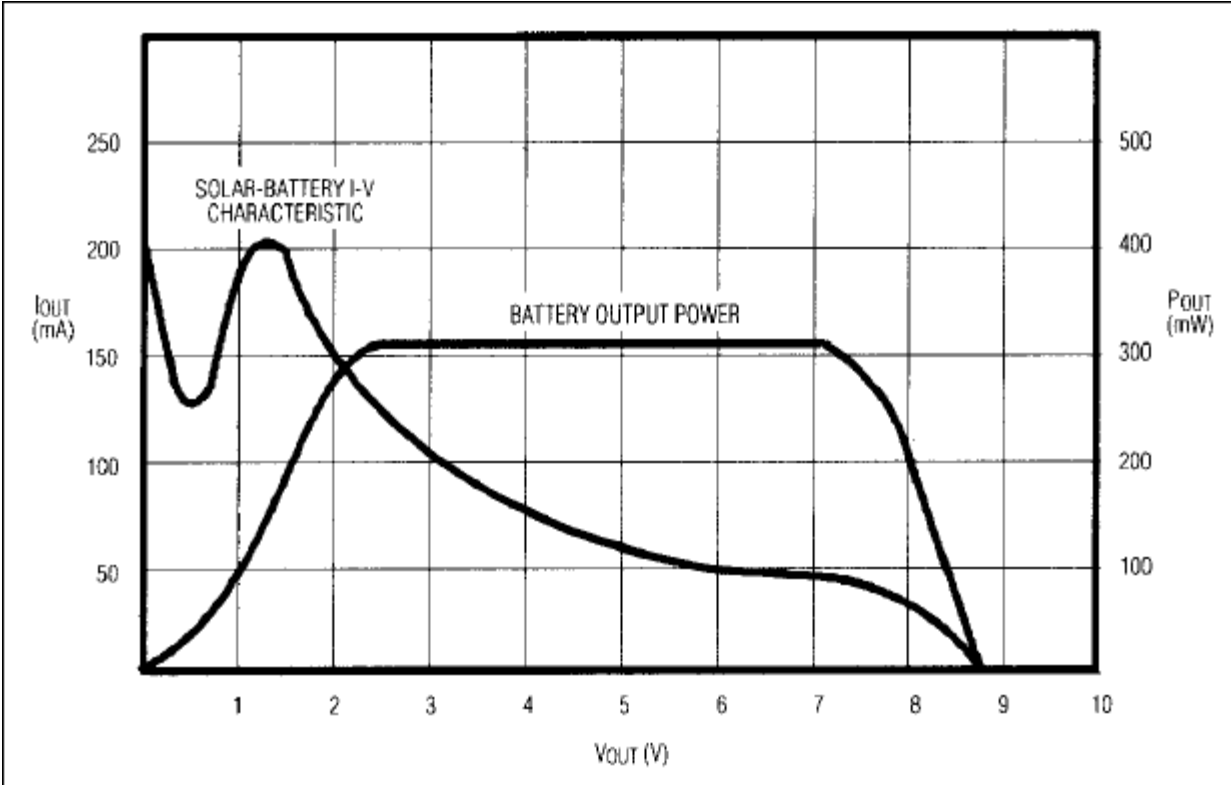

Figure 3. Combining the solar battery of Figure 1 with the charging circuit of Figure 2 extracts peak output power from the solar battery over most of its output-voltage range.

When "on," the regulator passes current from pin 6 to pin 5 through an internal switch resistance of less than 1 Ω . Combined with the regulator's low quiescent current (10 μ A typical) and high efficiency (85% typical), this performance allows the Figure 2 circuit to deliver as much as four times the power of a single-diode circuit.

Related Parts

[MAX639](#) 5V/3.3V/3V Adjustable, High-Efficiency, Low-I_Q, Step-Down DC-DC Converters -- [Free Samples](#)

Automatic Updates

Would you like to be automatically notified when new application notes are published in your areas of interest? [Sign up for EE-Mail™](#).

Application note 414: www.maxim-ic.com/an414

More information

For technical support: www.maxim-ic.com/support

For samples: www.maxim-ic.com/samples

Other questions and comments: www.maxim-ic.com/contact

AN414, AN 414, APP414, Appnote414, Appnote 414

Copyright © by Maxim Integrated Products

Additional legal notices: www.maxim-ic.com/legal