



APPLICATION NOTE 4121

## Class G and Charge-Pump Technologies Maximize Efficiency in Boosted Amplifiers with Minimal Support Components

*Abstract: Maxim introduces innovative charge-pump-based boosted amplifiers with Class G technology. Designed for portable applications that require output levels above traditional values, these amplifiers do not sacrifice efficiency or PCB real estate. This application note describes the advantages of using charge-pump and Class G technologies to power loudspeakers. The MAX9730 and MAX9788 speaker amplifiers serve as examples of the new designs.*

### Introduction

A common problem in portable audio applications is the limited supply voltage available to the speaker amplifier. Lithium ion (Li+) batteries are typically used in these audio systems, which produce 3.7V nominally. While a 3.7V supply is sufficient to run most elements of the system, the speaker amplifier requires more voltage to generate acceptable sound pressure levels. Consequently, most speaker amplifiers power transducers in a bridge-tied-load configuration, which allows twice the supply voltage to be applied to the speaker.

Although doubling the supply voltage to the speaker is sufficient in many cases, some applications require even more output power. Two examples are systems that either use piezoelectric speakers (which require high voltage drive) or require high sound-pressure levels (such as GPS devices). The only solution for these demanding audio applications is to boost the supply voltage, which typically requires a separate DC-DC boost converter and adds cost and complexity to the system.

The [MAX9730](#) and [MAX9788](#) Class G power amplifiers solve this supply-voltage problem by using a charge pump to boost the supply voltage. The MAX9730 specifically addresses traditional dynamic speakers, while the MAX9788 addresses ceramic speakers.

### The Novel Charge-Pump Approach

The MAX9730 and MAX9788 amplifiers use charge-pump technology to allow up to twice the output level, compared to a standard 5V amplifier. Fully integrated into the amplifier, the charge pump only requires two external capacitors, which can be as small as 0603 ceramic surface-mount capacitors. The integrated charge pump generates a negative voltage with a magnitude equal to the supply. This effectively doubles the supply voltage, thereby doubling the possible output voltage.

Unlike a DC-DC boost converter, a charge pump has an appreciable output resistance that causes the negative supply to droop when a load is applied. Consequently, the MAX9730's and MAX9788's design ensures that the output resistance of the charge pump is low enough to allow a significant increase in output power. While a traditional amplifier operating from 3.7V can output 700mW into an 8Ω load, the MAX9730 can output 1.3W under the same conditions.

### Class G Technology Uniquely Suits this Application

Since the MAX9730 and MAX9788 use a 10V amplifier instead of the typical 5V amplifiers found in handheld equipment, maintaining high efficiency is essential to maximizing battery life. While Class D technology is highly efficient and often used in handheld devices, it is not compatible with ceramic speakers. The design challenge

was clear: something else was required for ceramic speakers. Class G, a relatively unknown amplifier technology, emerged as the perfect fit.

Class G amplifiers operate just like Class AB amplifiers except that Class G uses multiple supply voltages instead of one fixed voltage. As the input signal varies in amplitude, the Class G approach automatically selects the appropriate supply to minimize the voltage drop across the output transistors. Efficiency improves significantly. Typically Class G amplifiers operate from two positive supplies and ground. The high supply is used for large output levels, and the lower supply is used for small output levels.

The MAX9730 and MAX9788 apply Class G technology in a unique fashion, taking advantage of the inverted supply from the charge pump instead of a high and low positive supply. When the amplifier is generating a small output signal, the amplifier uses the battery voltage and ground as its supply. In this mode, the device operates like a typical 5V Class AB amplifier (**Figure 1a**). When the output signal exceeds the capability of the supply, the amplifier switches to using the battery voltage and the inverted charge pump output (**Figure 1b**). The amplifier can then output signals much higher than a traditional amplifier.

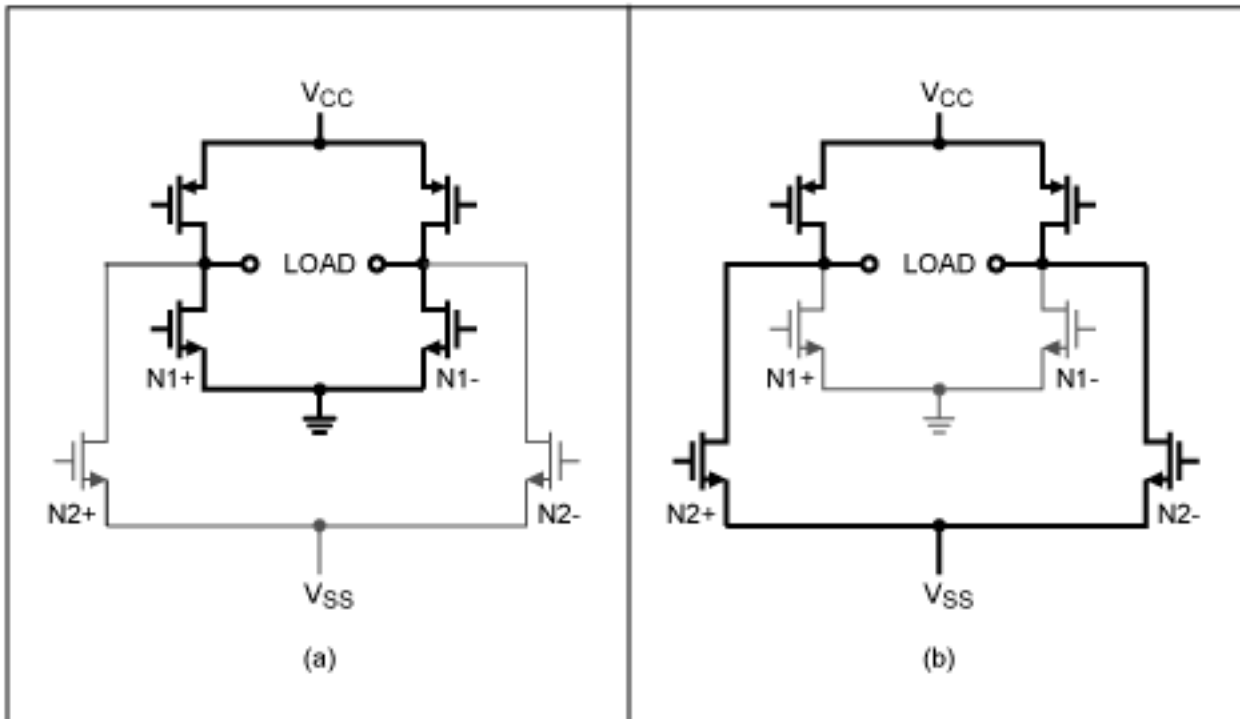

Figure 1a and b. MAX9788 Class G output stage operating from the low supply (a), and from the high supply (b).

The MAX9730 and MAX9788 ensure that the transition between the two supplies does not cause any audible artifacts. When the output signal reaches the limit of what is possible using  $V_{CC}$  and GND, the negative supply is automatically connected to the output stage. The output signal then no longer clips on the negative swing, but still clips on positive swings. To correct for this, the amplifier adds an additional correction signal to the opposite output. This effect is shown in **Figure 2**. When the positive and negative outputs are observed individually, the positive swing of the waveform is clearly clipped and the negative swing is clearly distorted. While these signals appear heavily distorted, they are actually carefully manipulated to take advantage of the architecture. The actual output signal applied to the load is an undistorted signal.

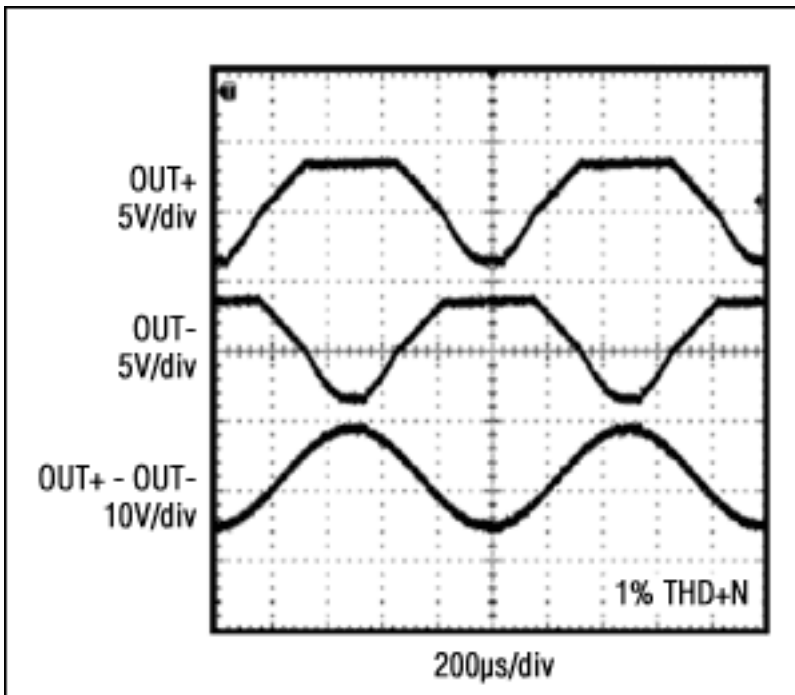

Figure 2. A Class G output waveform generated with the MAX9788 amplifier.

## Summary

Using Class G technology in combination with an inverting charge-pump, the MAX9730 and MAX9788 offer a unique solution to a common problem. While most boosted amplifier solutions require a bulky inductor, the MAX9730 and MAX9788 use only two small ceramic capacitors to operate, saving both PCB space and cost. Also, the MAX9730 and MAX9788 improve upon existing designs by utilizing an efficient Class G architecture that reduces current consumption.

---

Application Note 4121: [www.maxim-ic.com/an4121](http://www.maxim-ic.com/an4121)

### More Information

For technical questions and support: [www.maxim-ic.com/support](http://www.maxim-ic.com/support)

For samples: [www.maxim-ic.com/samples](http://www.maxim-ic.com/samples)

Other questions and comments: [www.maxim-ic.com/contact](http://www.maxim-ic.com/contact)

---

### Keep Me Informed

Preview new application notes in your areas of interest as soon as they are published. Subscribe to [EE-Mail - Application Notes](#) for weekly updates.

AN4121, AN 4121, APP4121, Appnote4121, Appnote 4121

Copyright © by Maxim Integrated Products

Additional legal notices: [www.maxim-ic.com/legal](http://www.maxim-ic.com/legal)