



APPLICATION NOTE 411

Derive 12V From 8V to 15V Input

Abstract: The buck/boost converter successfully addresses the challenge of regulating a 12V from the wide input-voltage swing associated with the sealed lead-acid battery.

Derive 12V From 8V to 15V Input

You can't derive a regulated 12V output from a 12V lead-acid battery by using a simple boost converter because it can't accept an input voltage that is greater than its output voltage. Conversely, a buck converter is a combination of buck and boost circuitry that successfully addresses the challenge of the wide input-voltage swing associated with the sealed lead-acid battery.

The circuit of the MAX641 is a buck/boost converter that provides 100mA at 12V and accepts 8V to 16V inputs. Both ends of the circuit's inductor are switched by separate power MOSFETs, which the MAX641 drives directly via its L_X and EXT outputs. These outputs operate out of phase, the p- and n-channel FETs turn on at the same time. When both n- and p-channel FETs turn off, the two Schottky diodes steer the coil's discharge current to the 12V output. A slight drawback of this circuit is that the converter's efficiency is less than that of a pure buck or boost converter, because the two MOSFETs and two diodes increase losses in the charge and discharge current paths. Nevertheless, the circuit still delivers 100mA at a respectable 70% efficiency figure.

An additional benefit of this type of circuit is that you can control its operation with a TTL-level signal. Overriding the V_{FB} input with a high-level TTL signal (such as the diode-coupled inverter output shown) fools the MAX641's internal feedback circuitry into thinking that the output is too high, so the chip turns off both MOSFETs. The circuit's idle current is around 400 μ A.

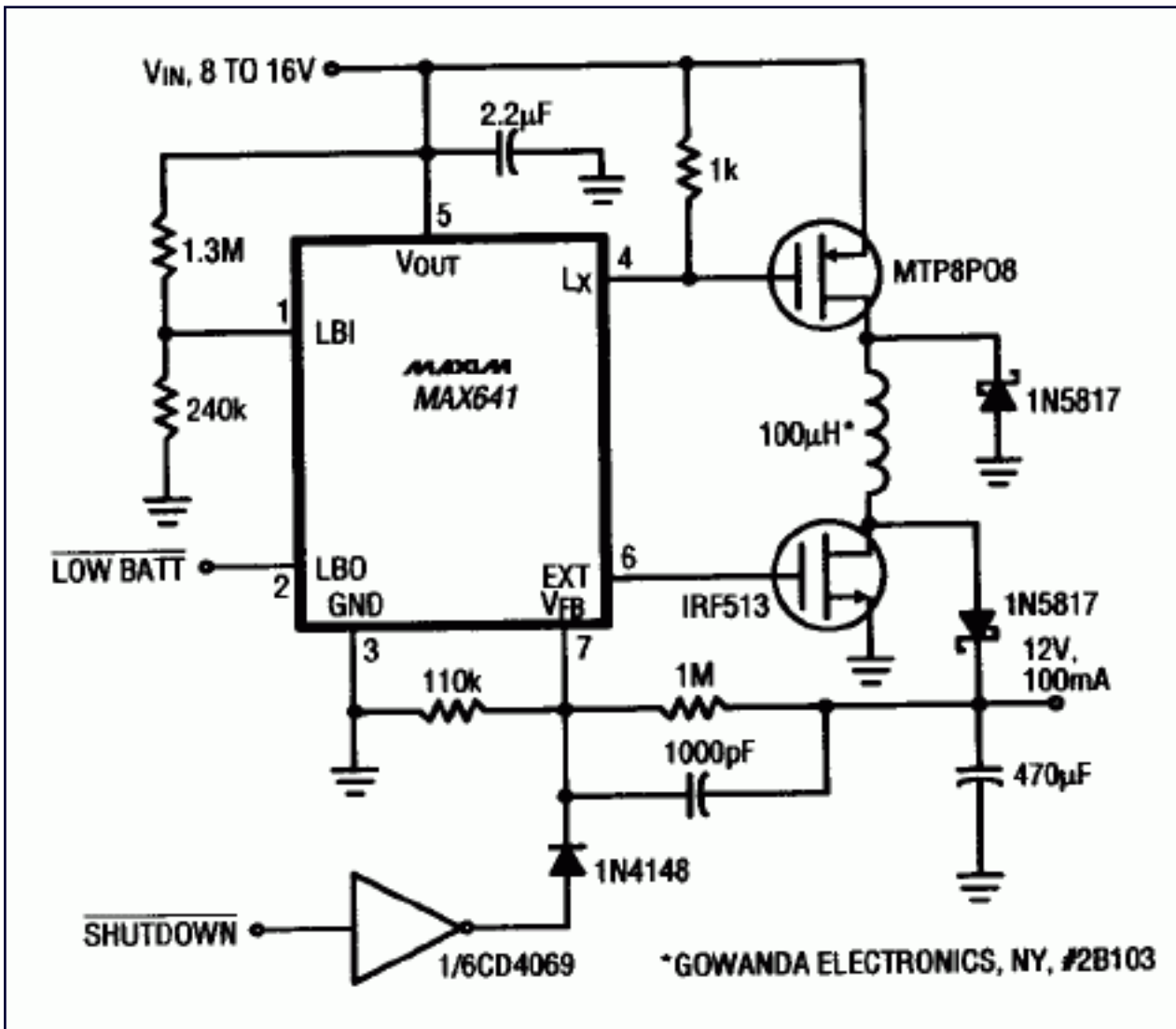

Application Note 411: <http://www.maxim-ic.com/an411>

More Information

For technical questions and support: <http://www.maxim-ic.com/support>

For samples: <http://www.maxim-ic.com/samples>

Other questions and comments: <http://www.maxim-ic.com/contact>

Related Parts

MAX641: [QuickView](#) -- [Full \(PDF\) Data Sheet](#) -- [Free Samples](#)

AN411, AN 411, APP411, Appnote411, Appnote 411

Copyright © by Maxim Integrated Products

Additional legal notices: <http://www.maxim-ic.com/legal>