

APPLICATION NOTE 4101

Differentiating Digital Potentiometer Features

Abstract: Digital potentiometers (digipots) facilitate digital control and adjustment of resistances, voltages, and currents in analog circuitry for a wide range of applications. This application note presents the basic functionality of digipots. The article also explains how digipots can be modified and features added to enhance system performance, simplify designs, and meet the requirements of a specific application.

Introduction

Digital potentiometers, or digipots, facilitate digital control and adjustment of resistances, voltages, and currents in analog circuitry. Common digipot applications include power-supply calibration, audio volume control, brightness control, gain adjustment, and control of bias and modulation currents in optical modules. Beyond basic digipot specifications, there are a number of features that can improve system performance and simplify designs. Among these features are various types of nonvolatility, zero-crossing detection, debounced pushbutton interfaces, temperature compensation, and write protection. The relevance of each of these features varies with the application.

Basic Digipot Design

A true potentiometer is a three-terminal device (see **Figure 1a**). The low terminal, V_L , is either internally connected to device ground or pinned out for design flexibility. This three-terminal digipot configuration is essentially an adjustable resistive divider with a fixed, end-to-end resistance.

A variable resistor is a two-terminal digipot variant with the wiper and one end of the resistor string available (see **Figure 1b**). Adjusting the position of the wiper in a variable-resistor digipot configuration effectively modifies the end-to-end resistance of the digipot.

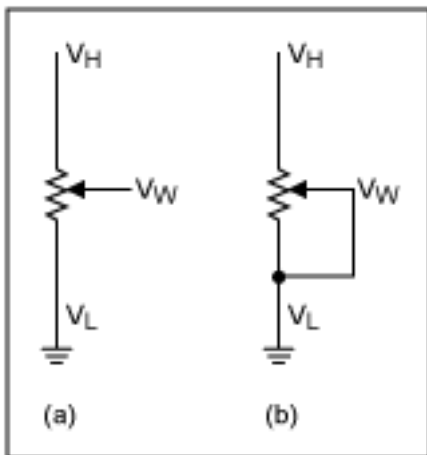

Figure 1. (a) A three-terminal digipot configuration is essentially an adjustable resistive divider with a fixed end-to-end resistance. (b) A variable resistor is a two-terminal digipot variant with the wiper internally connected to one side of the potentiometer.

Put simply, a digipot is an analog output controlled by a digital input. This description is similar to the definition of a digital-to-analog converter (DAC). Unlike DACs, which provide a buffered output, most digipots are not intended to drive low-impedance loads without an external buffer.

Depending on the digipot, maximum wiper currents range from the hundreds of microamps to milliamps. When connecting a digipot wiper to a low impedance, regardless of whether a variable resistor or a true digipot is used, always ensure that the wiper current will remain within the allowable I_{WIPER} range under worst-case conditions.

The worst-case wiper loading for a variable resistor occurs when V_W approaches V_H . At this point, there might be little resistance, apart from the wiper resistance, in the circuit to limit the current. There are, however, some applications where the wiper current is inherently large. Under these conditions the voltage drop across the wiper should definitely be considered, as this drop limits the digipot output's dynamic range.

Modifications for Application Needs

Circuits employing digipots vary widely. In some designs it might be necessary to "fine tune" the digipot for a specific application by adding external components. As an example, common end-to-end resistance values for digipots range between 10k Ω and 200k Ω . When controlling LED tile brightness, however, a much lower resistance is often required. A solution to this problem is found within the [DS3906](#), which provides effective resistances between 70 Ω and 102 Ω when placed in parallel with a fixed 105 Ω resistor. The 0.5 Ω step size in this configuration allows precise adjustment of LED brightness. Another solution can be found with multichannel digipots such as the [MAX5477](#) or [MAX5487](#), which combine the channels to vary the resistance step size while maintaining the digipot resolution.

In other cases a digipot with more specialized features might be needed. Applications that require temperature-compensated voltages or currents, such as laser-driver biasing in optical modules, benefit from lookup-table-based variable resistors. Some digipots integrate an EEPROM that stores thermal calibration lookup data in temperature increments; an internal temperature sensor measures the ambient temperature. The digipot then adjusts the variable resistor by using the modifier in the lookup table that corresponds to the measured temperature. Thermal lookup-table-based digipots typically either correct for a nonlinear temperature response from a circuit element, such as a laser or a photodiode, or intentionally create a precise, nonlinear resistive temperature response that is specific to an application.

Nonvolatility is a common and inexpensive add-on feature for digipots. Standard EEPROM-based nonvolatile (NV) digipots power up into a known state during power-on-reset (POR). EEPROM technology easily guarantees 50,000 write cycles, which is a significant reliability upgrade when compared to mechanical potentiometers. One-time programmable (OTP) digipots, such as the [MAX5427/MAX5428/MAX5429](#), permanently store the default wiper position using fuse programming. As with EEPROM-based digipots, after POR, OTP digipots initialize to a known state. However, the POR state of an OTP digipot cannot be rewritten once programmed. Consequently, OTP is well suited for factory or production calibration. While fuse programming permanently sets the POR wiper position for OTP digipots, fuse programming does not necessarily lock the wiper position. The wipers of many OTP digipots are fully adjustable after fuse programming. Yet in other OTP digipots, the wiper position is permanently set, resulting in a precise, calibrated resistor-divider. Some digipots offer a lockout register, or a digital control input, that tri-states the digipot interface, preventing inadvertent wiper adjustment. Disabling write capability in EEPROM digipots also reduces power consumption.

Digipots can help automate voltage and current calibration in power supplies or other systems that require factory calibration. Digipots increase manufacturing throughput and improve calibration accuracy and repeatability, when compared to more time-consuming and inexact manual calibration using mechanical potentiometers or discrete resistors. In addition, digital control of the potentiometer facilitates remote debugging and recalibration when desired. In systems where multiple voltages and/or currents are calibrated, digipots such as the [DS3904/DS3905](#) triple NV digipots are ideal (**Figure 2**). In this case one small digipot replaces up to three mechanical potentiometers. Layout flexibility also increases when digipots replace mechanical pots, as the digipots need not be readily accessible to technicians for calibration during assembly or rework. Calibration is a prime example of an application where OTP or EEPROM write-protection is desirable, and EEPROM write-protection can be useful as well.

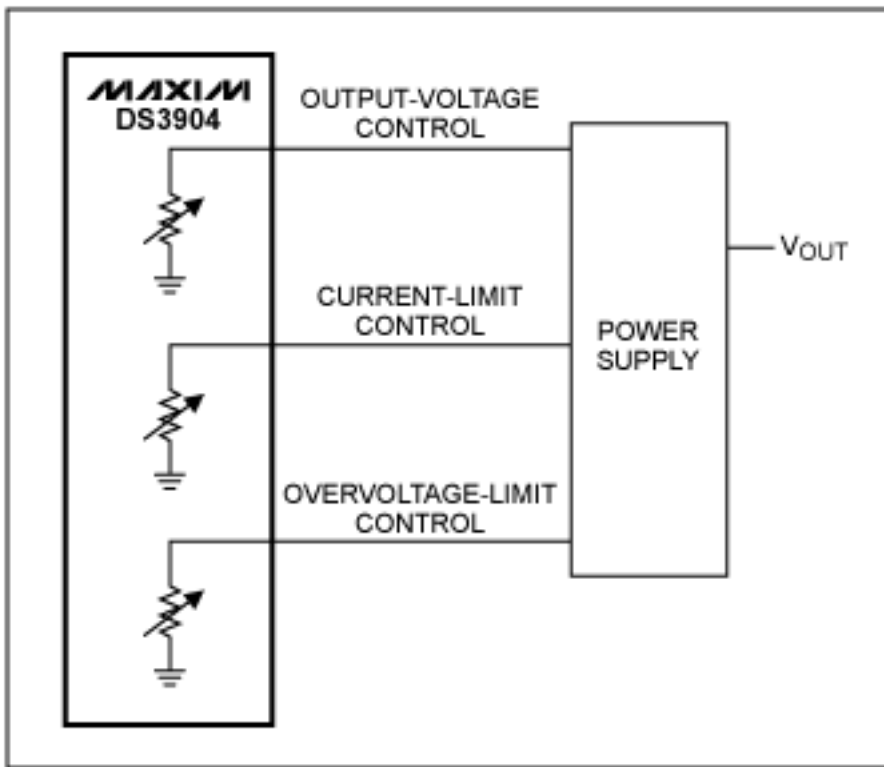

Figure 2. The DS3904/DS3905 triple nonvolatile digipots are ideal in systems where multiple voltages and/or currents are calibrated. This one small IC replaces up to three mechanical potentiometers.

Although not a digital potentiometer, a sample-and-hold voltage reference with a simple one-pin digital-control interface like the DS4303 can also assist with production calibration (Figure 3). Designed in a more compact space, which is especially beneficial during calibration, the voltage reference's output samples an applied input voltage until locked by the control input. After the output is locked, it will not change until reprogrammed or until power is removed, regardless of the voltage applied at the input. The most recently latched output voltage is stored in EEPROM and restored after power cycling.

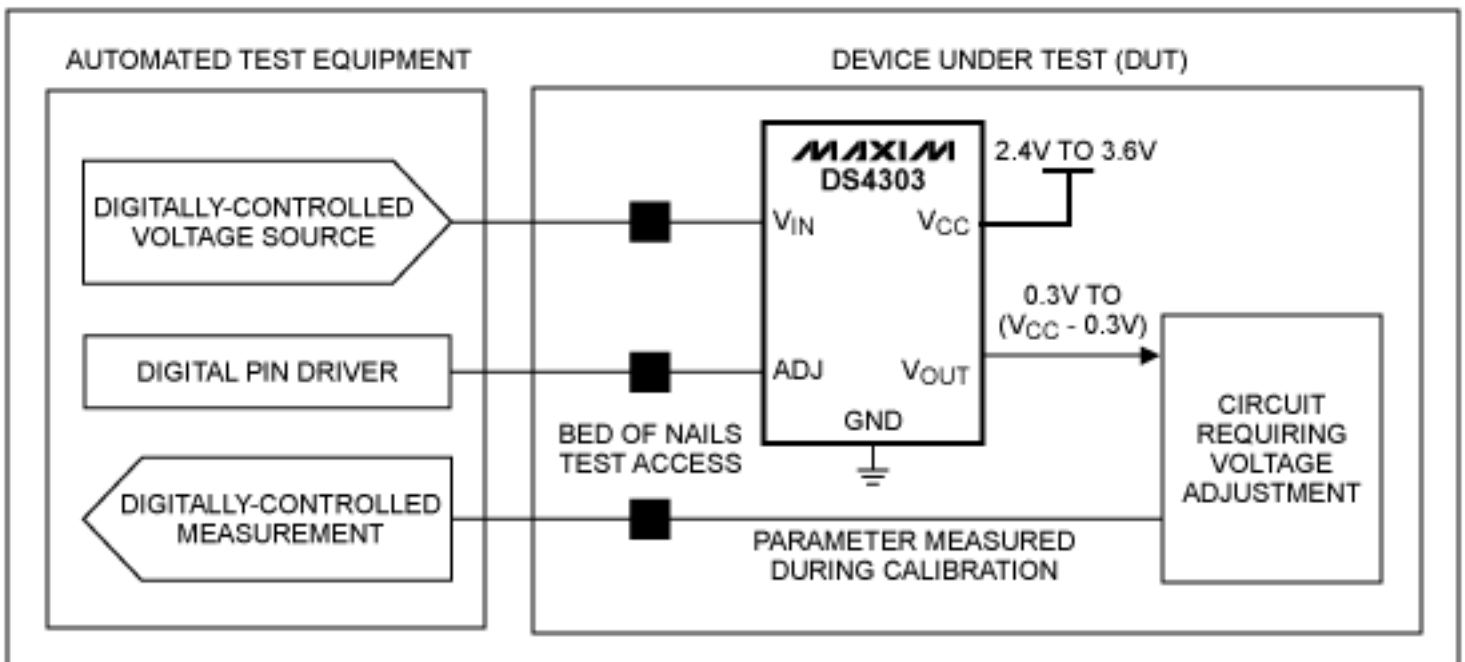

Figure 3. The nonvolatile DS4303 sample-and-hold voltage reference, although not a digital potentiometer, is useful for production calibration applications. During calibration, the DS4303's output (V_{OUT}) samples an applied input voltage (V_{IN}) until locked by the control input (ADJ).

Evolving pushbutton interfaces compliment traditional serial interface offerings like SPI™, I²C, increment/

decrement, and rotary control. One such interface is utilized in the [MAX5486](#) digipot with buffered wiper outputs. This debounced pushbutton interface advances the wiper at varied rates, depending on the duration of the button press. Pushbutton interfaces do not require a microcontroller, and hence reduce the system complexity. Debounced pushbutton interfaces are particularly useful for audio volume adjustment.

Digipots targeted for audio applications often feature zero-crossing-detection circuitry. Zero-crossing detection reduces the audible clicks and pops that can result when the wiper transitions from one setting to another. When active, zero-crossing detection delays wiper transitions until V_L is approximately equal to V_H . Many zero-crossing detection circuits also feature a maximum wiper-transition delay to facilitate DC applications and other specialized circuits.

Summary

Simple volatile digipots remain useful in system design, but digipots optimized for specific applications and variable resistors offer added functionality. Many designers today want to replace mechanical potentiometers, improve system reliability or performance over temperature, eliminate a need for a system microprocessor, or reduce audible clicks and pops. Whatever the need, digipots add value. Now there is also a digipot for most applications.

A similar article appeared in the May 2005 edition of *Electronic Products*.

SPI is a trademark of Motorola, Inc.

Application Note 4101: <http://www.maxim-ic.com/an4101>

More Information

For technical questions and support: <http://www.maxim-ic.com/support>

For samples: <http://www.maxim-ic.com/samples>

Other questions and comments: <http://www.maxim-ic.com/contact>

Related Parts

DS3904: [QuickView](#) -- [Full \(PDF\) Data Sheet](#) -- [Free Samples](#)

DS3906: [QuickView](#) -- [Full \(PDF\) Data Sheet](#) -- [Free Samples](#)

DS4303: [QuickView](#) -- [Full \(PDF\) Data Sheet](#) -- [Free Samples](#)

MAX5427: [QuickView](#) -- [Full \(PDF\) Data Sheet](#) -- [Free Samples](#)

MAX5428: [QuickView](#) -- [Full \(PDF\) Data Sheet](#) -- [Free Samples](#)

MAX5429: [QuickView](#) -- [Full \(PDF\) Data Sheet](#) -- [Free Samples](#)

MAX5457: [QuickView](#) -- [Full \(PDF\) Data Sheet](#) -- [Free Samples](#)

AN4101, AN 4101, APP4101, Appnote4101, Appnote 4101

Copyright © by Maxim Integrated Products

Additional legal notices: <http://www.maxim-ic.com/legal>