



Maxim > Design Support > Technical Documents > Application Notes > Amplifier and Comparator Circuits > APP 4088

Maxim > Design Support > Technical Documents > Application Notes > Power-Supply Circuits > APP 4088

Maxim > Design Support > Technical Documents > Application Notes > Video Circuits > APP 4088

Keywords: video, filter, amplifier, amp, low-power, low power, low power video, 1.8V, 1.8 volt, 2.5V, 2.5 volt, load detection, electrical load detection

Apr 01, 2008

APPLICATION NOTE 4088

# New-Generation Video Filter Amplifiers Extend Battery Life in Handheld Video Systems

By: Miles Bekgran  
Michael Petersen  
Apr 01, 2008

*Abstract: A growing number of portable devices, such as digital still cameras, cell phones, and portable media players, are adding composite video output connections. In these devices, the video digital-to-analog converter (DAC) generates the composite video signal, which must be lowpass filtered and amplified before reaching the output connector. Design engineers already consider power consumption, total cost, size, and video quality in choosing their video filter amplifiers. This article highlights how the new generation of video filter amplifiers can extend battery life and describes the additional requirements for the next generation of portable equipment.*

This article was also featured in [Maxim's Engineering Journal](#), vol. 61 (PDF, 440kB).

A similar article appeared in the October 2007 issue of [Electronic Products](#).

Increasing numbers of portable devices, like digital still cameras, cell phones, and portable media players, are adding composite-video output connections. In such devices, a video filter amplifier follows the video digital-to-analog converter (DAC) that generates the video signal. Today's 3.3V video filter amplifiers consume about 45mW of power while processing a video signal, which can cause a significant drain on battery power.

Battery life is an important issue for all portable equipment, and any system IC that can extend the battery life provides important benefits. It makes the handheld system more appealing to the user, because the device is plugged in less frequently for charging, so the user can be more mobile. Extended battery life also means that fewer disposable batteries are thrown away and there is less dependence on the grid for charging rechargeable batteries, both of which have a positive effect on the environment. Maxim's newest generation of video filter amplifiers, which operate from 1.8V, consume only 12mW—nearly a 70% reduction in power consumption when compared to the current 3.3V video filter amplifiers.

## Where Does All the Power Go?

In the simplest analysis, each circuit consumes power for its own operation and for driving the load. In Figure 1, the power supply provides total current ( $I_T$ ) to the circuit, where  $I_Q$  is the quiescent current for the operational amplifier and  $I_L$  is the load current.

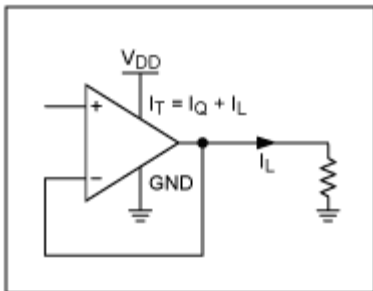

Figure 1. A single-supply operational amplifier is shown with a resistive load to ground.

Power is calculated by multiplying the current by the supply voltage. The quiescent power consumption ( $P_Q$ ), the load power consumption ( $P_L$ ), and the total power consumption ( $P_T$ ) are calculated to the first order with the following formulas:

$$P_Q = V_{DD} \times I_Q$$

$$P_L = V_{DD} \times I_L$$

$$P_T = P_Q + P_L = V_{DD} \times (I_Q + I_L)$$

To minimize actual power consumption in a real application, both  $P_Q$  and  $P_L$  must be reduced. Decreasing any combination of  $V_{DD}$ ,  $I_Q$ , and  $I_L$  achieves this end.

Usually, IC data sheets provide specifications for only  $I_Q$  or  $P_Q$ ; they almost never describe average power consumption with a typical signal and a typical load.  $P_Q$  is nearly useless information for any portable video filter amplifier, because the circuit is either in shutdown or fully enabled (defined as when the video filter amplifier drives a video signal into a video load). To conserve the battery, the video filter amplifier should be in shutdown if there is no video load; enabling the video filter amplifier when there is no video load wastes the battery.

## Power Consumption in 3.3V Video Filter Amplifiers

When a 3.3V video filter amplifier drives a video signal into a video load, its power consumption increases, as shown in Table 1. Average power consumption is defined as the condition in which the video filter amplifier drives a 50% flat-field video signal into a 150Ω load to ground. The 50% flat-field signal, which appears as a gray screen on a television, is used as a proxy for a typical video signal. (The  $P_L$  depends on the picture content. A black screen requires the least power, while a white screen requires the most power.) Note in Table 1 how the average power consumption of the parts is quite similar, although their  $P_Q$  differs considerably.

Table 1. Average and Quiescent Power Consumption of Various Video Filter Amplifiers

Company	Part	Supply Voltage (V)	Average Current (mA)	Average Power (mW)	$I_Q$ (mA)	$P_Q$ (mW)	Output Style
Maxim®	MAX9502	3.3	13.5	44.6	5.3	17.5	Positive DC bias
TI®	OPA360	3.3	12.2	40.1	6	19.8	Zero DC bias
Maxim	MAX9503	3.3	13.2	43.4	12	39.6	DirectDrive®

The increase in power consumption from driving a video signal into a video load greatly depends on the output style of the video amplifier. The MAX9502 outputs a video signal with a positive DC bias (see Figure 2). Maintaining the output signal's positive DC bias would cause an increase in overall power consumption. Therefore, the MAX9502 must source approximately 8.7mA (calculated by dividing the voltage, represented by the heavy blue line in Figure 2b, by 150Ω).

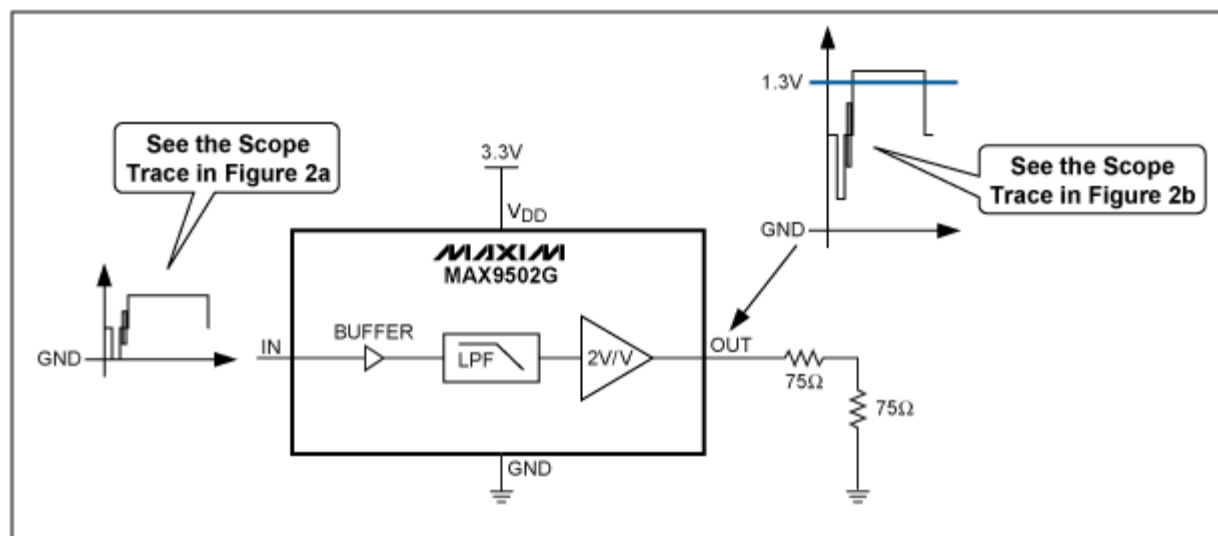

Figure 2. The MAX9502G application circuit shows the input and output of a 50% flat-field signal.

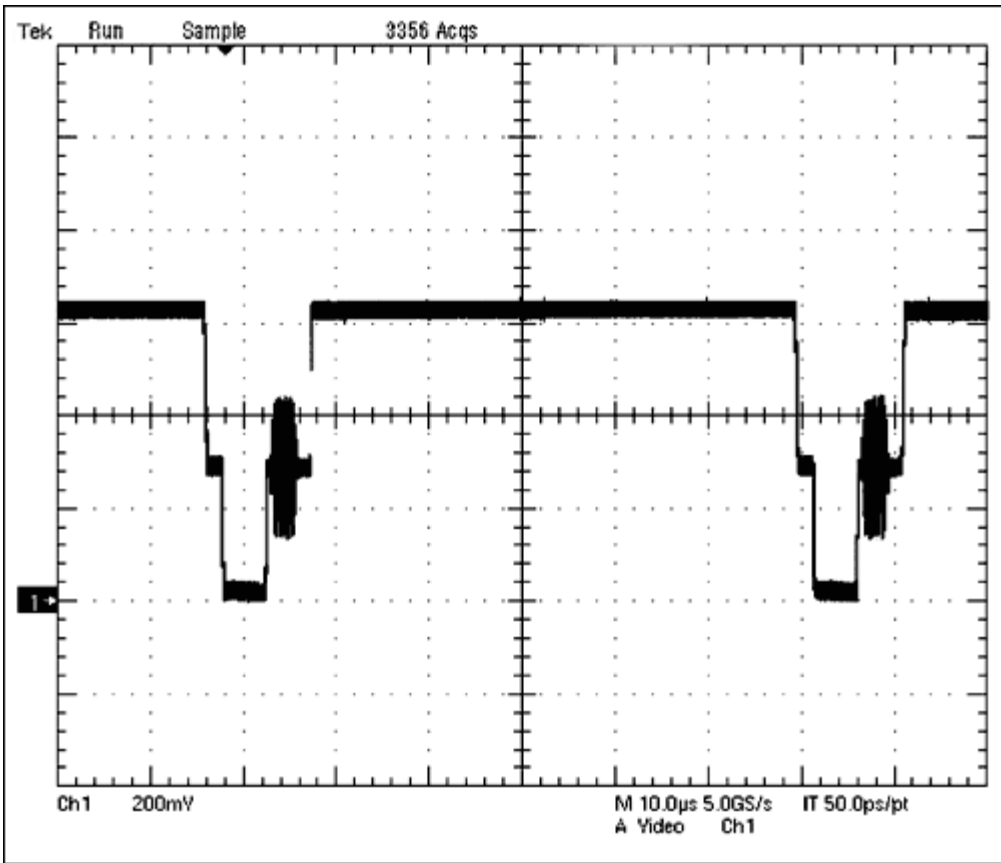

Figure 2a. This 50% flat-field waveform is input into the video filter amplifiers being considered.

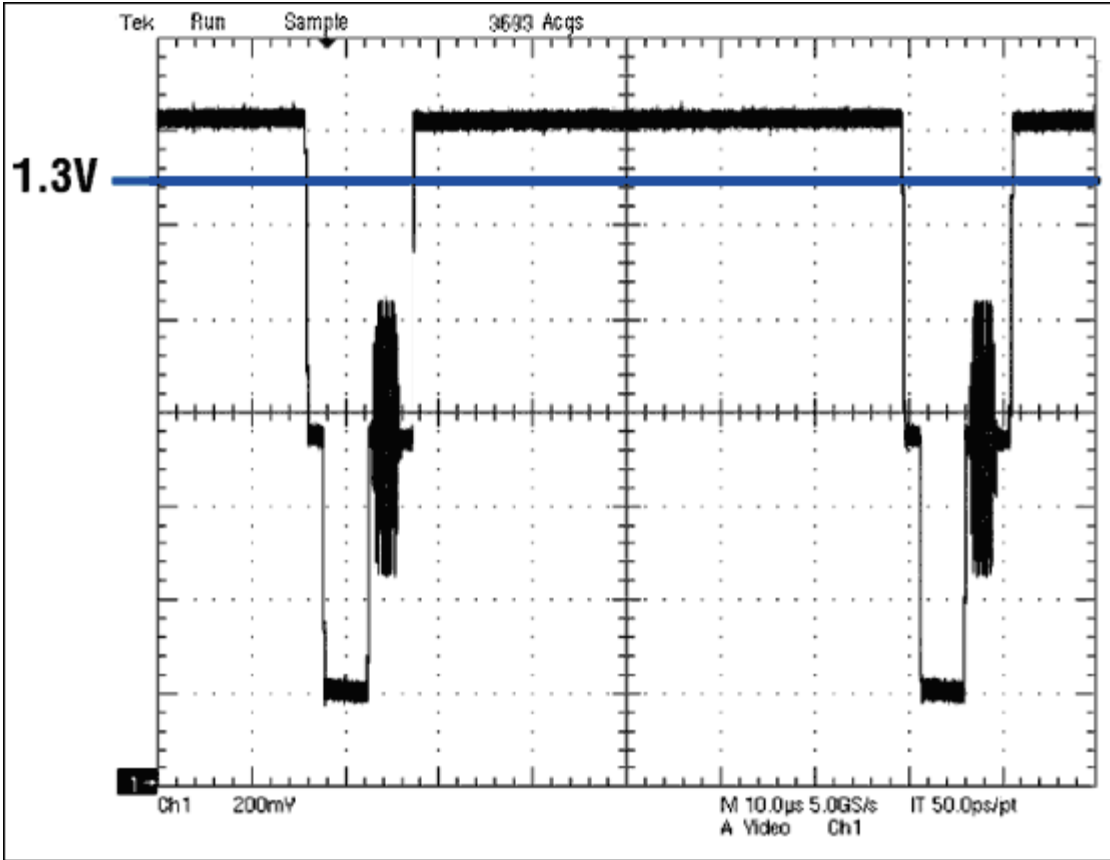

Figure 2b. In the MAX9502G's output waveform, the blue line indicates the approximate DC average of a 50% flat-field signal.

At its output, the OPA360 (in Table 1) can work with a SAG network, which is composed of two AC-coupling capacitors (Figure 3). These capacitors break the DC connection between the output and the load. As a result, the amplifier does not need to source or sink any current to maintain the bias at the output, thereby minimizing the power increase.

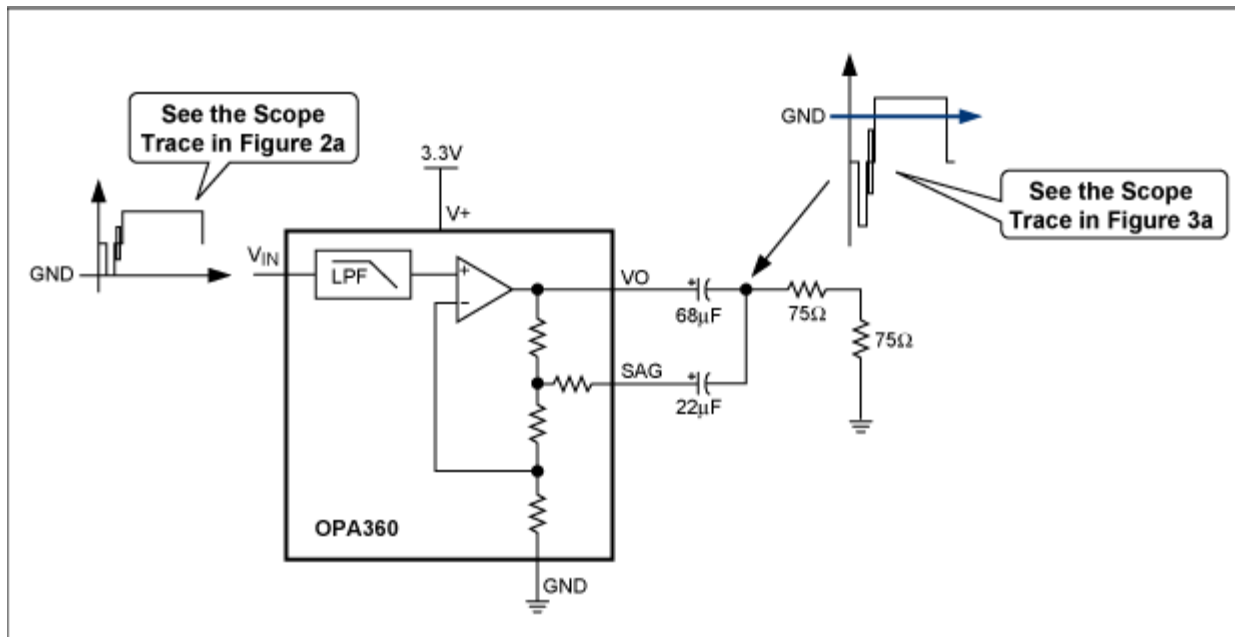

Figure 3. Given a 50% flat-field signal, the OPA360 application circuit minimizes power increase because the capacitors break the DC connection between the output and the load.

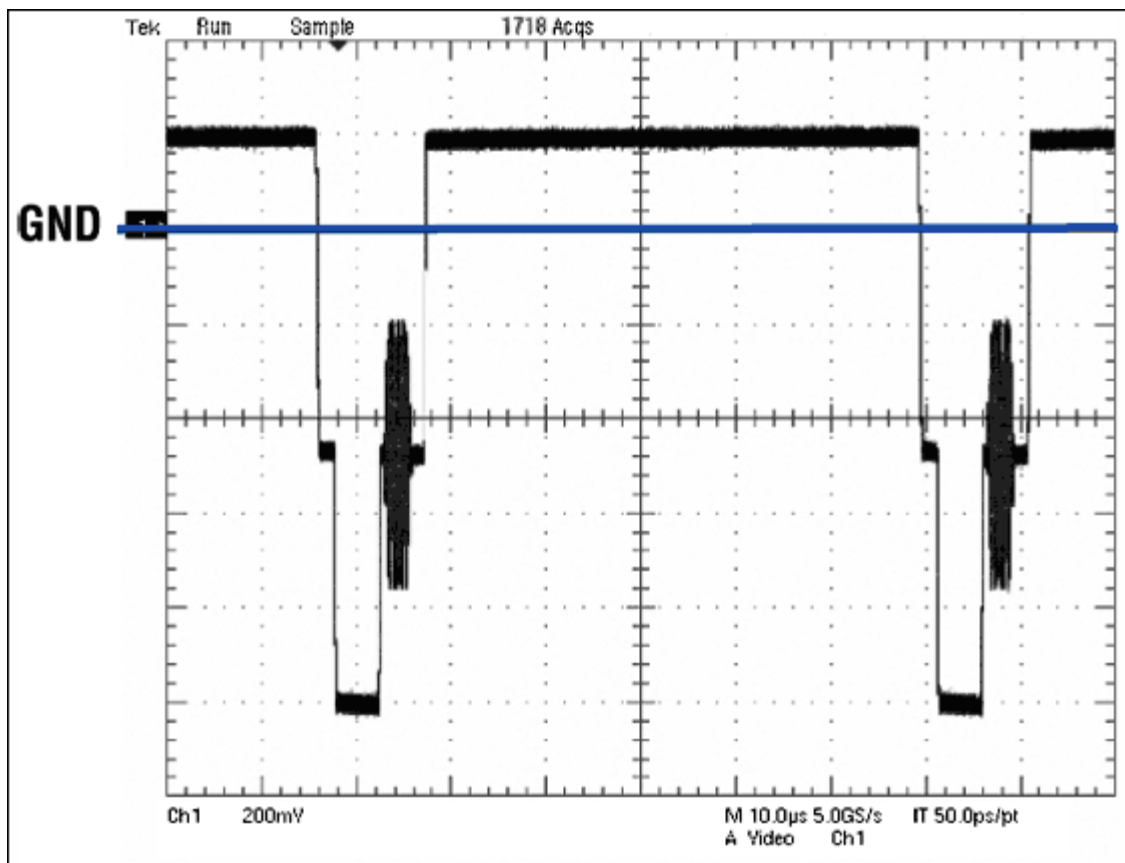

Figure 3a. The OPA360's output waveform contains a blue line indicating the approximate DC average of a 50% flat-field signal.

By using Maxim's DirectDrive technology, the MAX9503 outputs a video signal with close to zero DC bias, but does not require any AC-coupling capacitors (see Figure 4). This technology allows the MAX9503 to pull the output below ground because an on-chip, inverting charge pump creates a negative supply voltage. Although DirectDrive increases the  $P_Q$ , the MAX9503's average power consumption is in the same range as the MAX9502 and the OPA360 because the  $P_L$  is lower. The MAX9503 needs to source less current because the DC bias is close to ground.

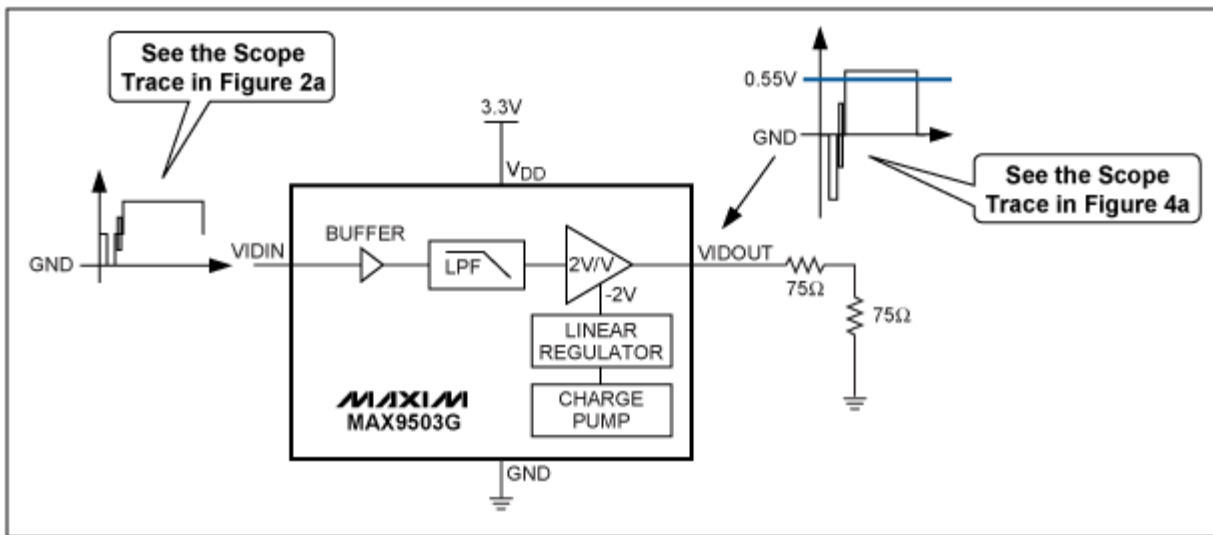

Figure 4. A 50% flat-field signal is processed through the MAX9503G application circuit.

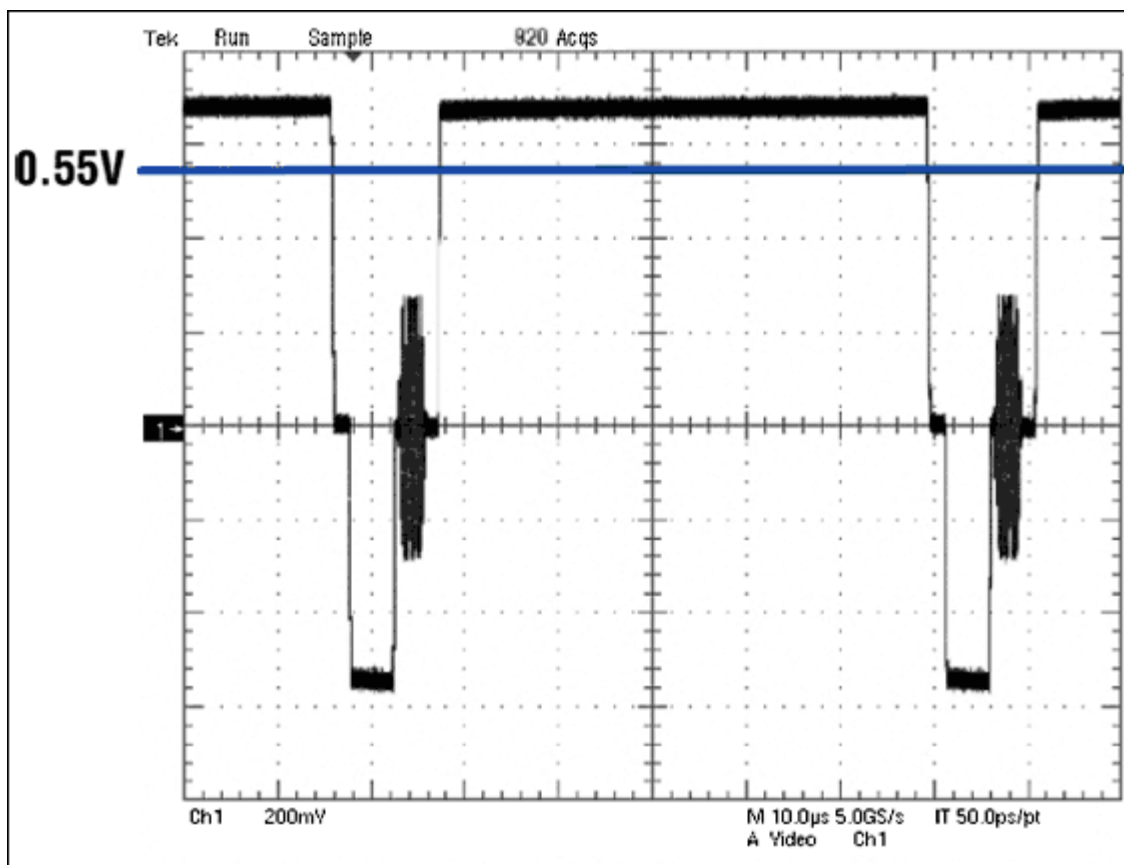

Figure 4a. The MAX9503G's output waveform has a blue line indicating the approximate DC average of a 50% flat-field signal.

## Power Consumption in the New Generation: 1.8V Video Filter Amplifiers

The MAX9509, the first released part in Maxim's newest video filter amplifier family, dramatically reduces both average power consumption and  $P_Q$ , as can be seen in Figure 5. Its supply voltage ( $V_{DD}$ ) has been reduced from 3.3V to 1.8V, which is the digital I/O voltage to which mobile phones are migrating. The quiescent supply current ( $I_Q$ ) has also been reduced from 12mA to 3.1mA (see Table 2).

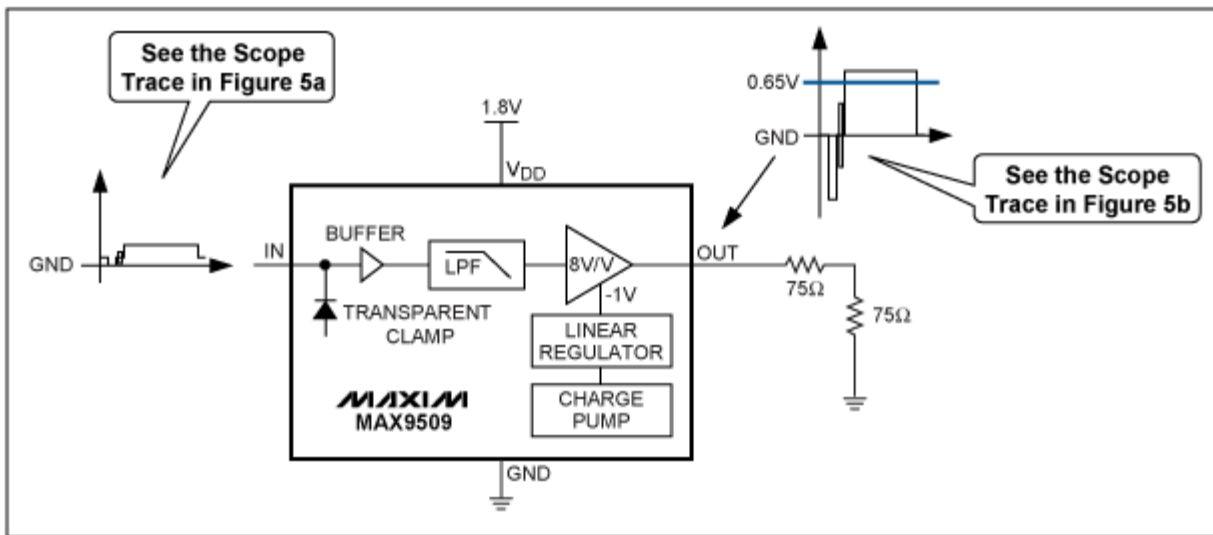

Figure 5. The MAX9509 1.8V application circuit processes a 50% flat-field signal, showing significantly reduced power consumption.

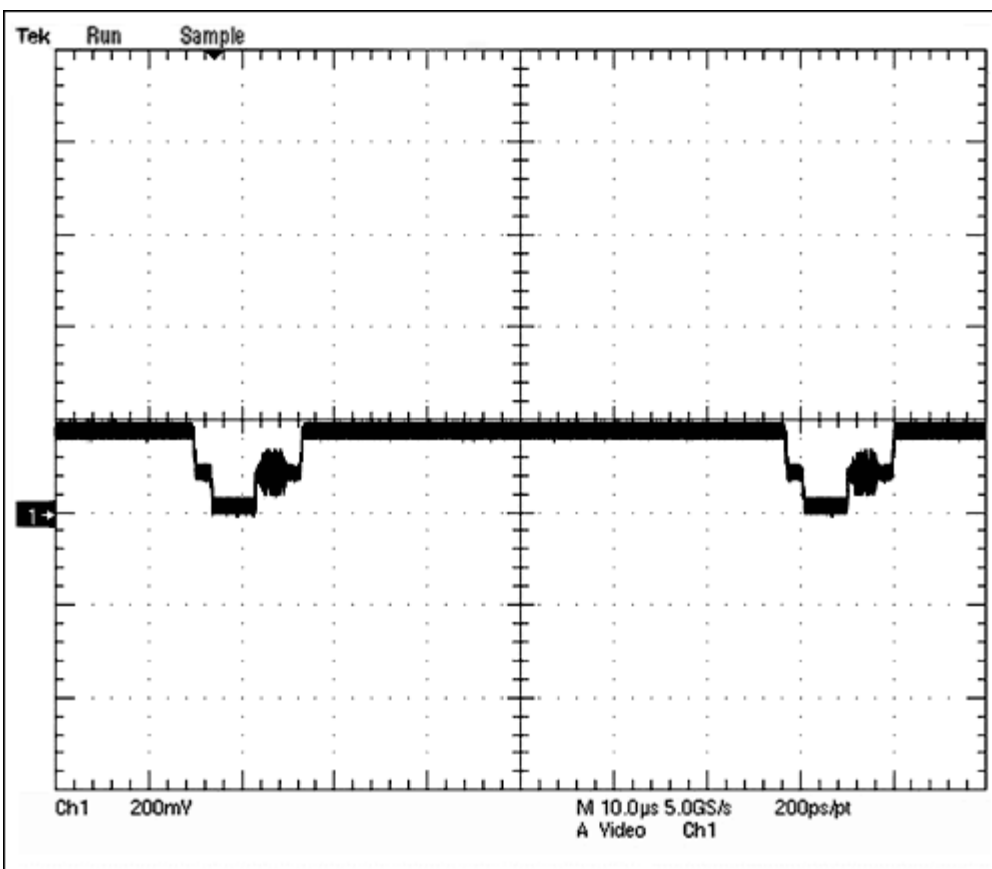

Figure 5a. A 50% flat-field waveform is input into the MAX9509; it has one-quarter the amplitude of the waveform used in Figure 2a.

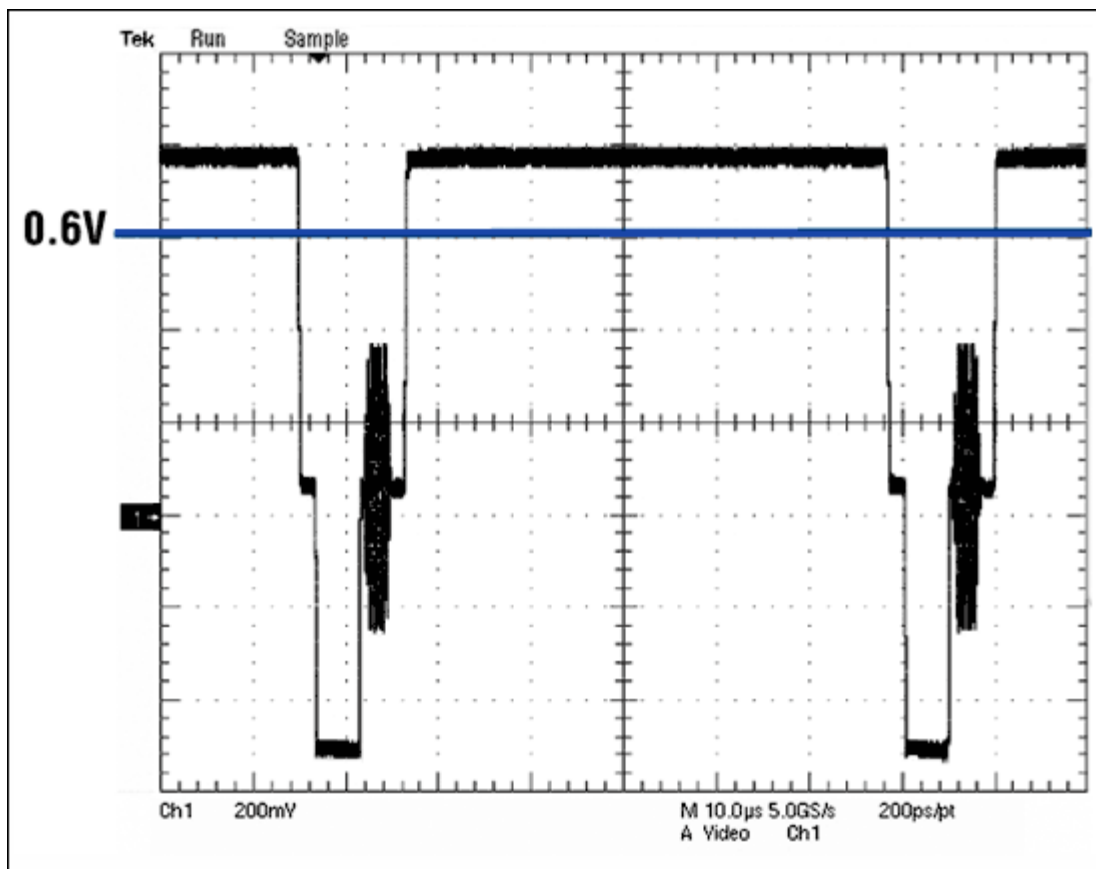

Figure 5b. In the MAX9509's output waveform, the blue line indicates the approximate DC average of a 50% flat-field signal.

Table 2. Average and Quiescent Power Consumption of the MAX9509

Company	Part	Supply Voltage (V)	Average Current (mA)	Average Power (mW)	$I_Q$ (mA)	$P_Q$ (mW)	Output Style
Maxim	MAX9509	1.8	6.5	11.7	3.1	6	DirectDrive

See the sidebar, *Circuit Considerations for 1.8V Video Filter Amplifiers*, for special issues to address when designing video circuits utilizing the new 1.8V digital I/O voltage.

DirectDrive is absolutely necessary when the video filter amplifier operates from a 1.8V supply. An amplifier with a voltage-mode output stage must swing at least  $2V_{P-P}$  to output a composite video signal. A traditional amplifier operating from a single 1.8V supply does not have enough headroom to handle a  $2V_{P-P}$  output signal. With DirectDrive, however, the integrated inverting charge pump creates a noisy -1.8V supply; a negative linear regulator then increases the -1.8V supply to -1V with minimal charge-pump noise. Therefore, due to a supply voltage that spans -1V to +1.8V, the MAX9509 now has just barely enough headroom to output the  $2V_{P-P}$  video signal.

With the combination of low supply voltage, low  $I_Q$ , and the DirectDrive output stage, the MAX9509's average power consumption (Table 2) is significantly lower than that of the 3.3V-generation devices seen in Table 1. This means that if the same battery is used for a system with the MAX9509 and for a system with one of the 3.3V devices, the battery would only need to supply up to 70% less power to the amplifier, thus extending battery life. This has a direct environmental impact, as disposable batteries would then be thrown away less frequently and there would be less dependence on the power grid for charging rechargeable batteries.

What is remarkable is that the MAX9509's average power consumption is lower than the  $P_Q$  of the 3.3V video filter amplifiers. One of the concerns with operating high-speed circuits at such a low power level is that the noise will greatly increase. This is because the circuits operate at lower current levels than normal. Noise was carefully considered during the MAX9509's design process, and this device has a very respectable peak signal-to-noise ratio (SNR) of 64dB, which is more than enough for consumer applications. To become visible on a video screen, the peak SNR needs to be around 40dB.

Having a noisy charge pump on the same die as the filter and amplifier was a major design concern. The charge pump could potentially inject switching noise into the delicate video waveform. The isolation between the MAX9509's charge pump and the video-

signal-path circuitry is so effective that the charge-pump noise is not evident on a frequency sweep (Figure 6) and is barely noticeable in the time domain (Figure 7).

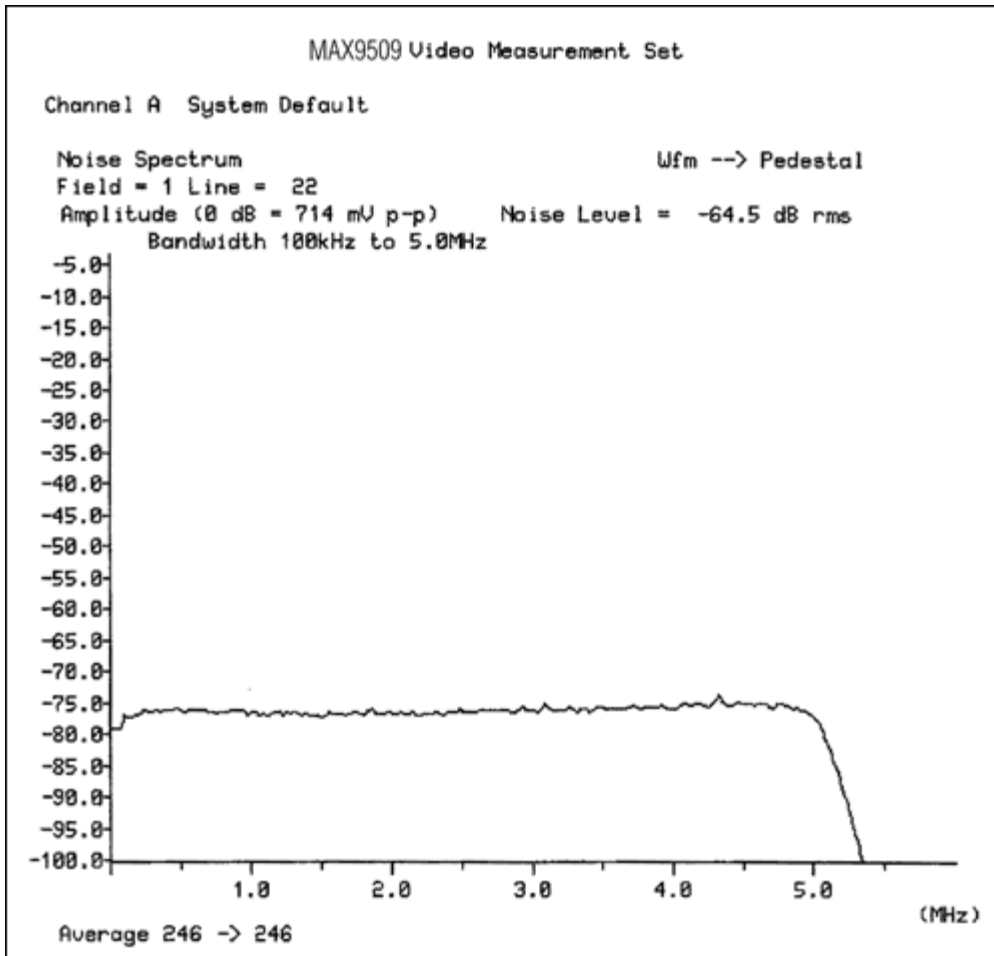

Figure 6. Charge-pump frequency spikes are not discernable when measuring the MAX9509's noise vs. frequency.

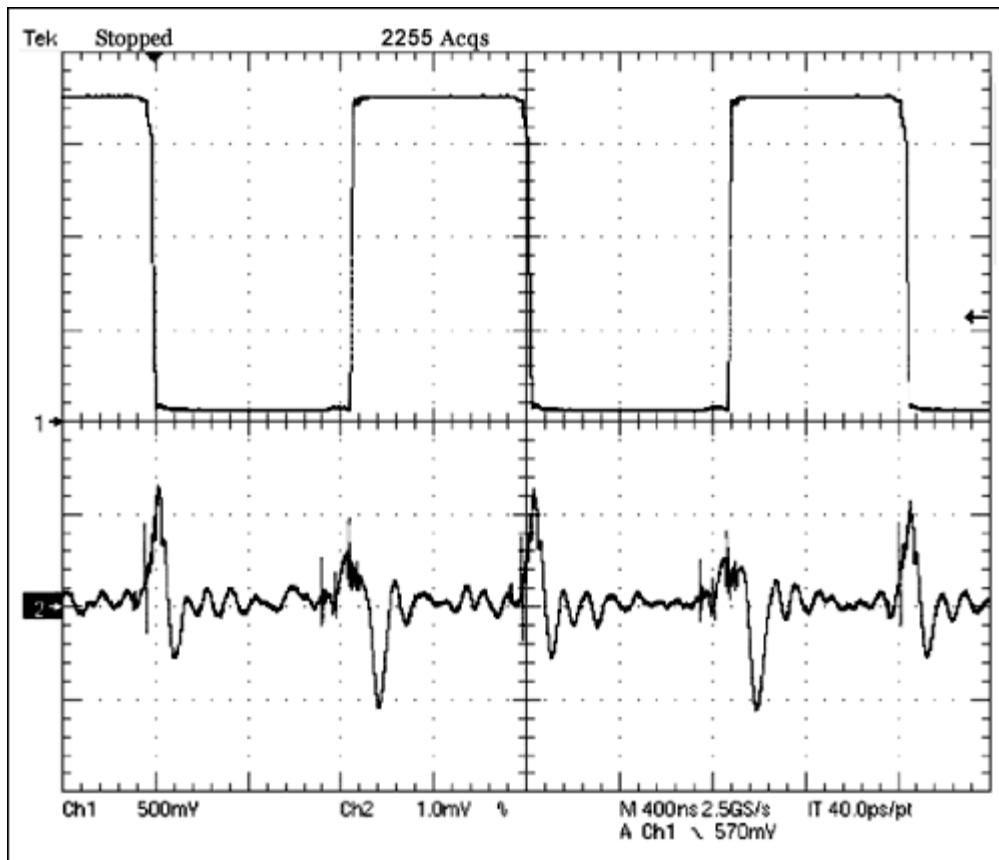

Figure 7. The MAX9509's output (bottom trace) is measured vs. time, taken with respect to a 1V<sub>P-P</sub> video signal. The spikes are 1.4mV<sub>P-P</sub>. The top trace is the voltage on the top plate of the charge pump's flying capacitor.

From the perspective of the consumer, neither wideband noise nor charge-pump noise are visible on a video screen displaying a signal output by the MAX9509.

## Future Direction for Low-Power Video Filter Amplifiers

While recent developments have been made in low-power video filter amplifiers, IC designers still have work to do. Consider video-load detection. If, for example, a video filter amplifier could electrically detect the load and provide load status to the microcontroller operating a system, then the video output circuitry could be turned on only when a valid video load was present. As a result, the system could manage video power more intelligently. The current method of video-load detection is to turn on the video output circuitry upon the mechanical detection of a jack insertion. This could waste battery power if the other end of the cable were not actually plugged into the jack of a television or other video monitor. A side benefit of electrical video-load detection is that it needs only a standard connector instead of a connector with mechanical jack sense, which adds cost and increases space compared to a standard connector.

Low power consumption has always been important in portable devices, but it is becoming more important even for wall-powered devices because of higher energy costs and concerns about global warming. Hence, the trend is for more intelligent power management to be integrated into analog chips. For the video filter amplifier, not only must it be low power, but it must have video-load detection, video-input detection, and control circuitry to cycle through operating modes. The greatest challenge will be to add intelligent power management without significantly increasing cost, as video chips are mostly used in competitively priced consumer electronics.

## Sidebar: Circuit Considerations for 1.8V Video Filter Amplifiers

Apart from designing affordable products with increasingly better features, companies worldwide are doing their best to design systems that are more and more environmental friendly. An IC that reduces power consumption and is available in a lead-free/ROHS-compliant package is an essential step in a designing an environmentally friendly product.

Special considerations were made in designing the MAX9509 low-power video filter amplifier. Bias current values were chosen to allocate the supply current where it is most productive. Layout techniques that result in smaller parasitics and good device matching were used. Finally, careful questioning and analysis was performed for the current used in all branches of the circuit. These efforts

have optimized power consumption, reducing the bandwidth of the circuitry to only what is required to maintain the necessary frequency response and video performance.

What makes the power consumption of the MAX9509 lower than previous generations of video filter amplifiers is careful circuit design and Maxim's advanced BiCMOS process technology. All of the circuits from the previous generation of video designs were analyzed and optimized to result in the lowest power consumption while still maintaining adequate performance for the intended applications. For example, the number of times that a bias current is mirrored between supply rails in the MAX9509 was reduced. Use of the generated negative rail was also minimized. Additionally, proprietary circuitry was applied to eliminate distortions that would otherwise be introduced by running the amplifier on such lean currents. The MAX9509's power consumption was also reduced by Maxim's advanced analog process technology, which permits the optimal selection of components (e.g., bipolar vs. MOS) for the particular video signal path. The MAX9509's 5-pole filter eliminates an extra biquad filter stage needed for previous generations of amplifiers with 6-pole filters (Figures 8 and 9). The difference in filter specifications between a 5-pole and 6-pole filter is minimal for consumer applications, and the elimination of a biquad filter stage enables greater than 10% reduction in overall supply current.

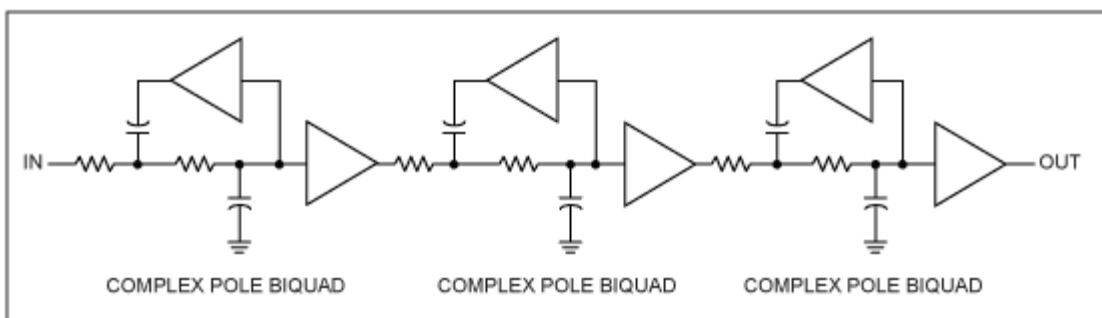

Figure 8. Previous generations of video filter amplifiers had 6-pole filters.

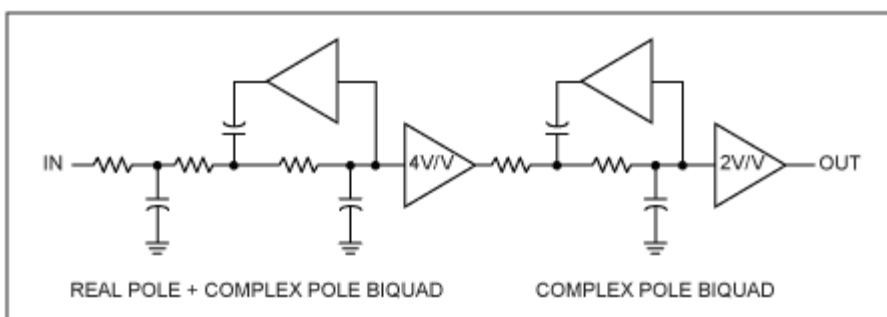

Figure 9. The MAX9509 has only a 5-pole filter, which eliminates a biquad filter stage, thus providing a 10% reduction in overall supply current.

Through careful partitioning of the filter and amplifier circuitry, the requirements of each block in the signal path can be optimized to use less total current for a given set of system specifications. For example, to achieve the gain of 8 in the MAX9509, a gain-of-4 preamplifier is used within the filter. Therefore, only a gain of 2V/V is required in the final video amplifier (Figure 9), thus reducing the requirements, and hence the power needs, of the final video amplifier. The overall power consumption of both amplifiers is low and optimized for the function being performed.

DirectDrive is a registered trademark and registered service mark of Maxim Integrated Products, Inc.

Maxim is a registered trademark of Maxim Integrated Products, Inc.

TI is a registered trademark and registered service mark of Texas Instruments Incorporated.

Related Parts		
<a href="#">MAX9507</a>	1.8V, DirectDrive Video Filter Amplifier with Load Detection and Dual SPST Analog Switches	<a href="#">Free Samples</a>
<a href="#">MAX9509</a>	1.8V, Ultra-Low Power, DirectDrive Video Filter Amplifiers	<a href="#">Free Samples</a>
<a href="#">MAX9510</a>	1.8V, Ultra-Low Power, DirectDrive Video Filter Amplifiers	<a href="#">Free Samples</a>
<a href="#">MAX9516</a>	1.8V, Ultra-Low-Power, DirectDrive Video Filter Amplifier with Load Detect	<a href="#">Free Samples</a>

---

More Information

For Technical Support: <http://www.maxim-ic.com/support>

For Samples: <http://www.maxim-ic.com/samples>

Other Questions and Comments: <http://www.maxim-ic.com/contact>

---

Application Note 4088: <http://www.maxim-ic.com/an4088>

APPLICATION NOTE 4088, AN4088, AN 4088, APP4088, Appnote4088, Appnote 4088

Copyright © by Maxim Integrated Products

Additional Legal Notices: <http://www.maxim-ic.com/legal>