

APPLICATION NOTE 4075

How to Use the DS1864's Current DACs as Voltage DACs

Abstract: This article describes how to convert the current DACs in the DS1864 SFP laser controller/monitor to a voltage output by using standard components.

The Current DACs

The [DS1864](#) contains two 8-bit current-sink DACs with 1.5mA or 0.5mA selectable full-scale range. The DAC outputs must be at a voltage level between 0.7V and the DS1864's V_{CC} .

Current-to-Voltage Conversion

An operational amplifier in differential amplifier configuration is used to convert the 0.5mA full-scale current-mode output to 1V full-scale voltage-mode output (**Figure 1**).

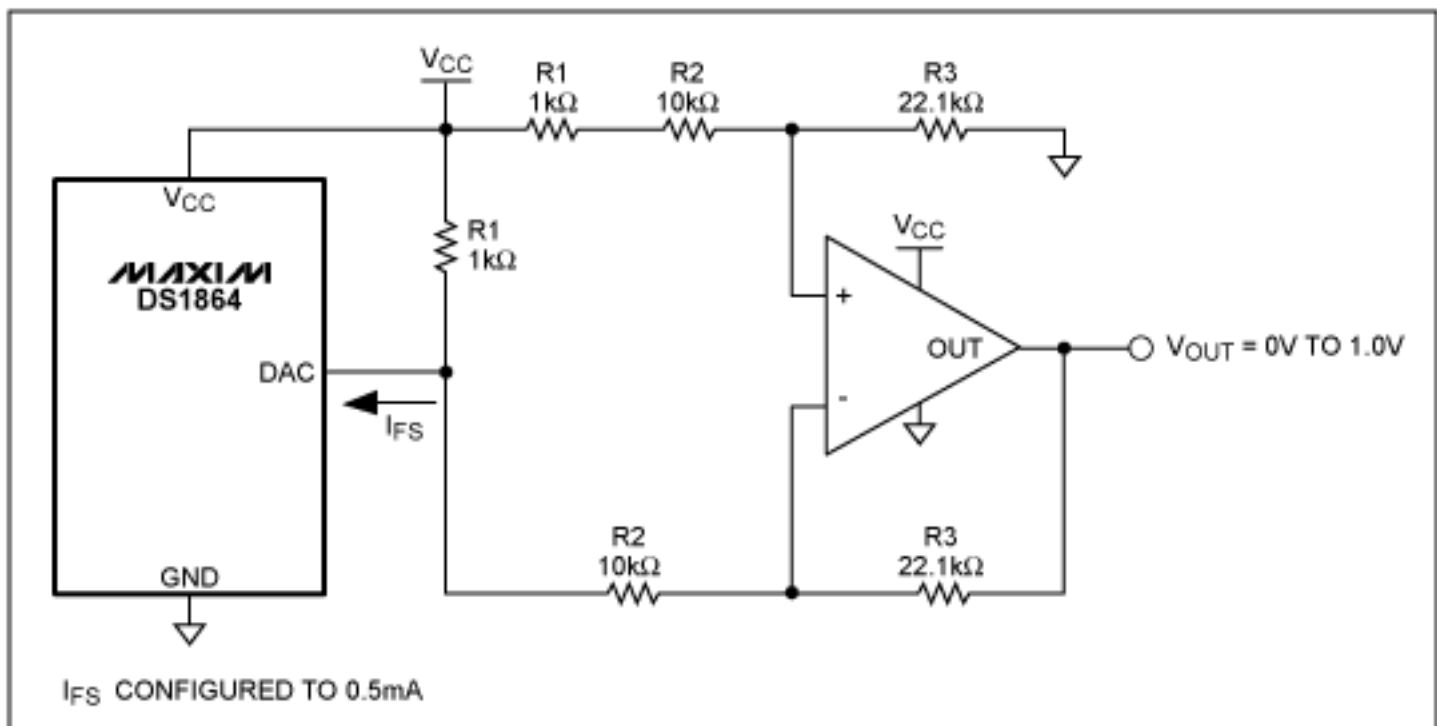

Figure 1. Circuit shows current-to-voltage conversion.

Compact Solution

Using a chip-scale packaged op amp and 0201 resistors will provide the most compact solution. The [MAX4233](#) is a two-channel op amp available in 1.5mm x 2mm 10-bump UCSP™.

Output Voltage Calculation

The output voltage is calculated in Equation 1.

$$V_{OUT} = \frac{(I_{DAC} \times R1)(R3)}{R1 + R2} \quad (\text{Eq. 1})$$

Using the values shown in the Figure 1 drawing, the maximum output voltage is 1.005V when the DAC current is 0.5mA. To minimize offset and gain errors, 1% tolerance resistors should be used. Further, R1 should be selected so that the voltage at the DAC pin never falls below 0.7V.

UCSP is a trademark of Maxim Integrated Products, Inc.

Application Note 4075: www.maxim-ic.com/an4075

More Information

For technical questions and support: www.maxim-ic.com/support

For samples: www.maxim-ic.com/samples

Other questions and comments: www.maxim-ic.com/contact

Keep Me Informed

Preview new application notes in your areas of interest as soon as they are published. Subscribe to [EE-Mail - Application Notes](#) for weekly updates.

Related Parts

DS1864: [QuickView](#) -- [Full \(PDF\) Data Sheet](#) -- [Free Samples](#)

MAX4233: [QuickView](#) -- [Full \(PDF\) Data Sheet](#) -- [Free Samples](#)

AN4075, AN 4075, APP4075, Appnote4075, Appnote 4075

Copyright © by Maxim Integrated Products

Additional legal notices: www.maxim-ic.com/legal