

APPLICATION NOTE 4050

Current Sensing on a Negative Voltage Supply Rail, using a Precision Instrumentation Amplifier

By: Akshay Bhat, Strategic Applications Engineer
Prashanth Holenarsipur, Lead Product Definer

Abstract: Applications like ISDN and telecom systems need a negative voltage, current-sense amplifier. This application note describes one method for designing a negative-rail, current-sense amplifier. The design is quite flexible and can be easily changed for monitoring different negative rails. The MAX4460 single-supply instrumentation amplifier is used to demonstrate the design.

Introduction

High-side current-sense amplifiers are used principally for monitoring the current from a positive supply rail. Applications like ISDN and telecom power supplies, however, require current-sense amplifiers that operate at negative rail. This application note describes one method for designing a negative-rail, current-sense amplifier.

Application Example

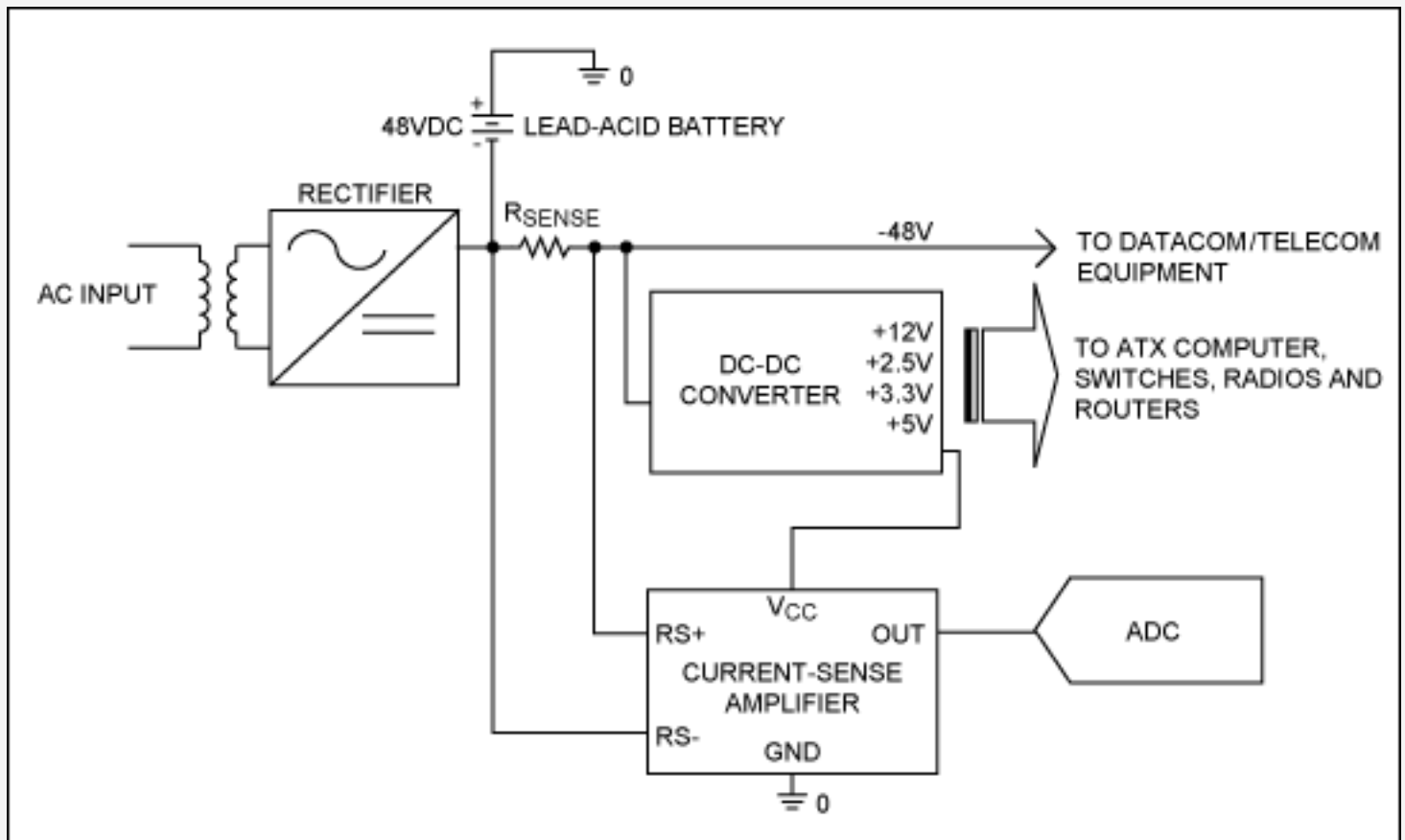

Figure 1. Block diagram of a telephone central-exchange, power-supply system.

Figure 1 shows a block diagram of the power-distribution network in a typical telephone exchange. A rectifier converts the AC at the power mains to DC, and the DC output from the rectifier is used to charge a 48V lead-acid battery. The battery powers the user telephones through the telephone line. The battery polarities are connected so that the line voltage is negative (-48V). A negative line voltage helps to reduce the corrosion from electrochemical reactions occurring on a wet telephone line. A telecom network also uses several DC-DC converters to derive intermediate power-supply rails from the -48V DC input. The intermediate power supply rails power the switches, radios, routers, ATX computers, and other electronic equipment in the telephone exchange. A current-sense amplifier oversees the system health by monitoring the -48V power-supply current.

Circuit Description

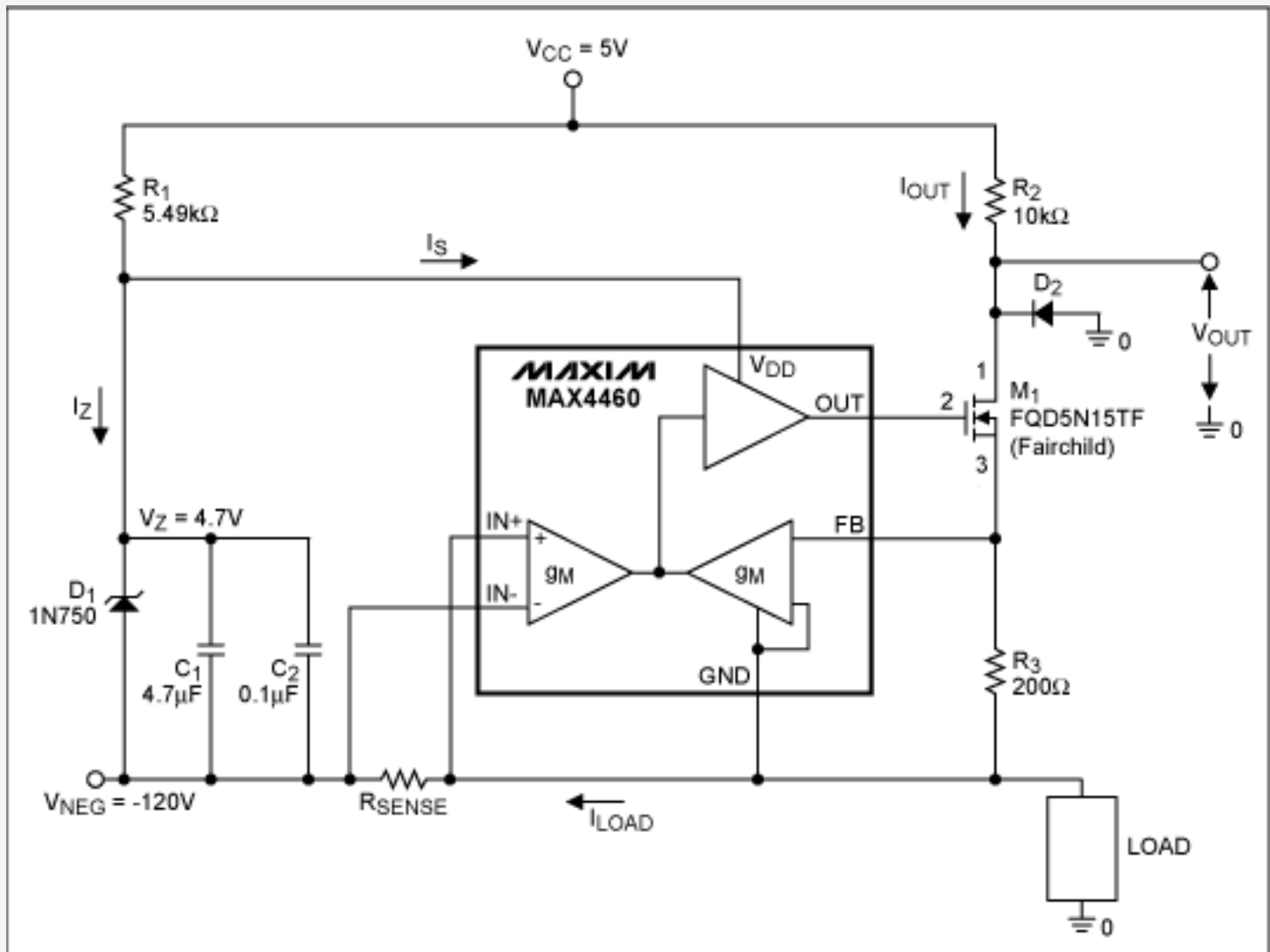

Figure 2. Negative-rail, current-sense amplifier using the MAX4460.

The circuit in **Figure 2** shows an implementation of the negative-rail, current-sensing block. It uses an instrumentation amplifier like the [MAX4460](#) or the [MAX4208](#) and some discrete components.

The zener diode, D_1 , protects the instrumentation amplifier from overvoltage damage while providing sufficient supply voltage for its operation. The current to be monitored flows to the negative supply through the sense resistor, R_{SENSE} . The instrumentation amplifier must have a single supply and operate with a ground-sensing capability.

The MAX4460's output provides the gate drive for MOSFET M_1 . Negative feedback ensures that the voltage drop across resistor R_3 equals V_{SENSE} , the voltage across R_{SENSE} . Consequently, R_3 sets a current proportional to the

load current:

$$I_{OUT} = (I_{LOAD} \times R_{SENSE})/R_3 = V_{SENSE}/R_3 \quad (\text{Eq. 1})$$

R_2 is chosen so that the output voltage lies within the desired range of the following circuit, typically an ADC. The drain-source breakdown voltage rating of the MOSFET must exceed the total voltage drop between the two supply rails (+125V in this case). An additional op-amp buffer can be used at V_{OUT} if the ADC does not have a high-impedance input. If the sense current increases above the rated value during a fault condition, then the output voltage goes negative. Diode D_2 protects the ADC from damage by limiting the negative voltage at output to one diode drop.

Design Steps

The above design can easily be adapted to add high-voltage, negative supply, current-sense monitoring capability. This flexibility is illustrated by choosing -120V as the negative rail. By using the following straightforward steps, one can design a current-sense amplifier for a different supply rail.

1. Specify the Zener Regulator

It is important to bias the zener on a point in its transfer characteristic that gives a low dynamic resistance (i.e., well into its reverse breakdown region) to prevent PSRR errors. **Figure 3** shows a plot of the zener current versus the zener voltage for a standard zener diode configured in reverse bias. Data show that the zener voltage is not well-regulated close to the breakdown voltage. A general rule then is to select the bias point to be about 25% of the maximum current specified by the power rating. This bias point gives a low dynamic resistance without wasting too much power. The bias point is set to the desired value by choosing the resistor, R_1 , based on the following equation:

$$I_{R1} = (V_{CC} + |V_{NEG}| - V_Z)/R_1 = I_S + I_Z \quad (\text{Eq. 2})$$

Where:

V_{CC} = Positive rail-supply voltage

V_Z = Regulated zener voltage

$|V_{NEG}|$ = Absolute value of the negative-rail voltage

I_S = Supply current for MAX4460

I_Z = Current through the zener diode

R_1 must have a suitable power rating and be able to withstand the large voltages across it. Alternatively, one can use a series-parallel combination of lower wattage resistors to ease these constraints.

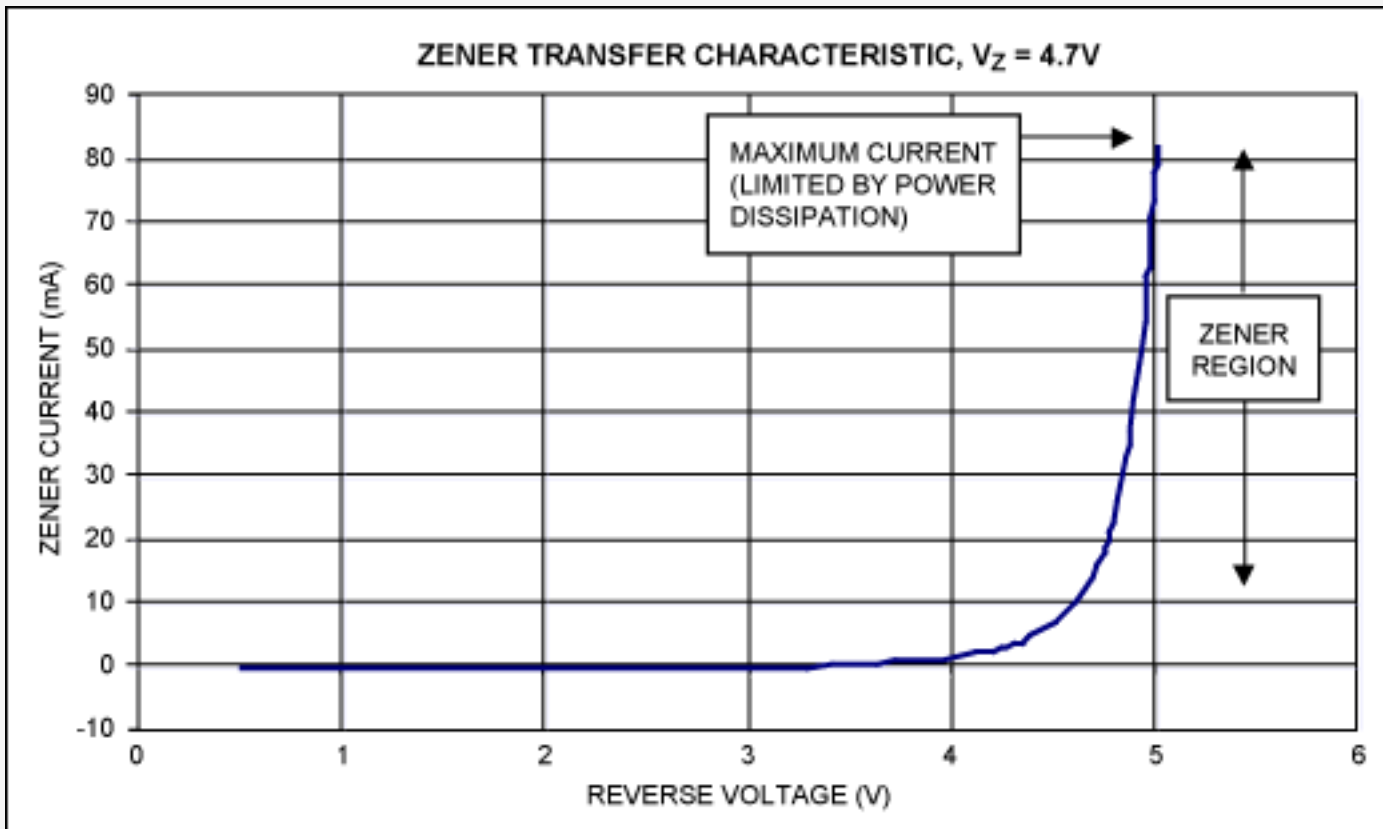

Figure 3. 1N750 Zener diode transfer characteristic, $V_Z = 4.7V$.

2. Select the Power Transistor

The n-channel MOSFET, or JFET, must have a drain to source breakdown voltage rating greater than $|V_{NEG}| + V_{CC}$. This is an important constraint if the negative supply voltage is high.

3. Choose R_{SENSE}

Select R_{SENSE} so that the full-scale, sense voltage across R_{SENSE} is less than or equal to 100mV.

4a. Select R_3

There is considerable flexibility in choosing R_3 . A good selection is influenced by the following two observations:

1. As R_3 is reduced, Equation 1 implies that for a fixed gain, the dissipated power increases.
2. The thermal noise and leakage current of the FET set the upper limit on the selected value of R_3 .

4b. Select R_2

The ratio of resistors R_2 and R_3 equals the voltage gain of the resulting current-sense amplifier. The output voltage is given as:

$$V_{OUT} = V_{CC} - I_{OUT} \times R_2 \quad (\text{Eq. 3})$$

From Equations 1 and 3 we get:

$$V_{OUT} = V_{CC} - (V_{SENSE} \times R_2/R_3)$$

Differentiating with respect to V_{SENSE} :

$$\text{Voltage gain, } A_v = -R_2/R_3 \quad (\text{Eq. 4})$$

The negative sign represents the inverting relationship between the output voltage and the input sense voltage. From Equation 4, R_2 can thus be determined.

Results

Figure 4 plots the resulting typical output voltage as a function of the sense voltage. The following typical parameters can be inferred for the current-sense amplifier:

$$\begin{aligned} \text{Input referred offset voltage} &= (5 - 4.9831)/49.942 \\ &= 338\mu\text{V} \end{aligned}$$

$$\text{Gain} = -49.942$$

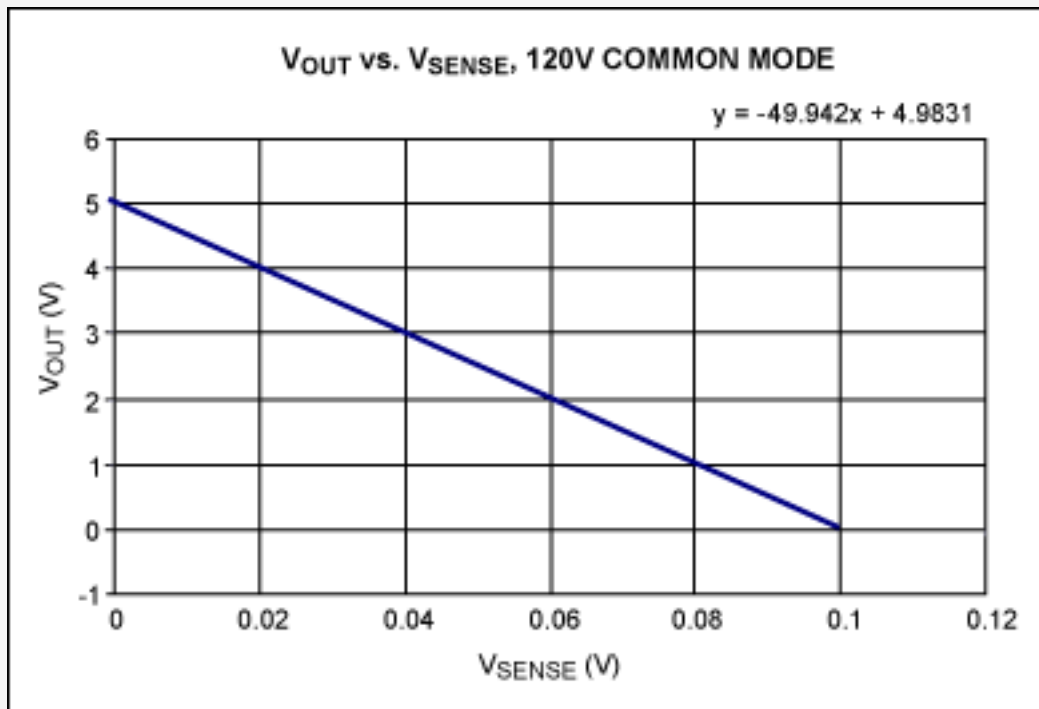

Figure 4. Output voltage variation with variation in sense voltage at $T = +25^{\circ}\text{C}$.

Conclusion

This application note demonstrates the use of a precision, instrumentation amplifier like the MAX4460 for current sensing of a negative voltage. The described circuit can be easily redesigned for monitoring different negative rails by following the design steps listed above.

A similar article appeared in the August, 2007 issue of *Power Electronics Technology* magazine, a Penton Publication.

Application note 4050: www.maxim-ic.com/an4050

More Information

For technical support: www.maxim-ic.com/support

For samples: www.maxim-ic.com/samples

Other questions and comments: www.maxim-ic.com/contact

Automatic Updates

Would you like to be automatically notified when new application notes are published in your areas of interest?

[Sign up for EE-Mail™](#).

Related Parts

MAX4208: [QuickView](#) -- [Full \(PDF\) Data Sheet](#) -- [Free Samples](#)

MAX4460: [QuickView](#) -- [Full \(PDF\) Data Sheet](#) -- [Free Samples](#)

AN4050, AN 4050, APP4050, Appnote4050, Appnote 4050

Copyright © by Maxim Integrated Products

Additional legal notices: www.maxim-ic.com/legal