



APPLICATION NOTE 4048

Use a DS3882 CCFL Controller to Drive a Two-Lamp Common-Return Configuration

Abstract: This application note describes a backlight LCD application in which two adjacent CCFL lamps share a common, low-voltage side lamp connection. This design is found in automotive, industrial, and avionic applications. The article describes how a DS3882 CCFL controller can be used to drive the two CCFL lamps that share a common return.

Introduction

The [DS3882](#) is a two-channel controller for cold-cathode fluorescent lamps (CCFL) that backlight liquid crystal displays (LCD) in automotive, industrial, and avionic applications. In some of these applications, the LCD panels contain two adjacent CCFL lamps that are mounted on one side of the panel. These arrangements typically use a common low-voltage, side lamp connection. This configuration presents a system challenge because the normal scheme of sensing lamp current on the low-voltage side of the lamp cannot be implemented when both lamps share a common return.

This application note describes how to use a CCFL controller to drive two CCFL lamps that share a common return. The article guides the practical implementation for this type of drive arrangement. The DS3882 CCFL controller will be used as the controller in the example.

Two-Lamp, Common-Return-Drive Scheme

The drive scheme shown in the DS3882's data sheet applies when access to the low-voltage side of each lamp is available. Driving two CCFL lamps that share a common low-voltage return, however, requires a different configuration. **Figure 1** shows how the CCFL lamps are arranged in an LCD panel. This alternate drive scheme uses the DS3882 to provide full protection for both lamps and adds only a few extra passive components. The unique design elements of this example configuration will be discussed in detail.

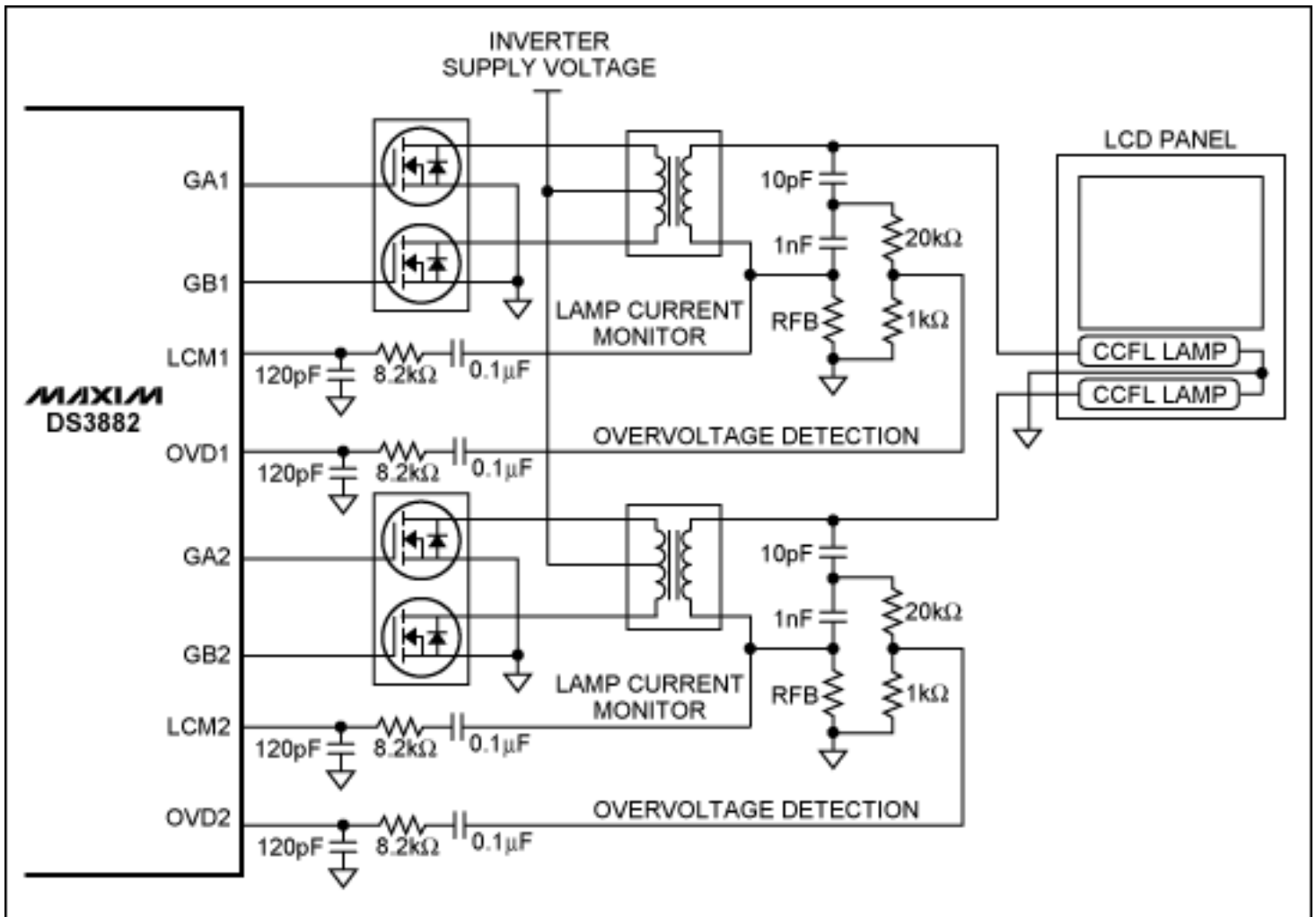

Figure 1. The DS3882 is shown in a two-lamp, common-return-drive scheme.

Change in Lamp Current-Sense Point

As the two lamps in the application share a common return, measuring the lamp current at the low-voltage side of the lamps is no longer possible. The drive scheme in Figure 1 places the lamp-current feedback resistor (RFB) on the low-voltage side of the transformer secondary, rather than on the low-voltage side of the lamp. This approach presents a design challenge: the current sensed in the RFB resistor consists not only of the current flowing through the lamp, but also current that flows due to parasitic capacitance in the LCD panel and due to the overvoltage capacitor-divider network (10pF and 1nF in Figure 1). In the drive scheme of Figure 1, the proper value for the RFB resistor can no longer be calculated in advance, but must be derived empirically because the amount of excess current from parasitic affects is not known. Nonetheless, to account for the current lost from the parasitic affects, the value of the RFB resistor must be somewhat lower than the value of a resistor placed at the low-voltage side of the lamp. If one assumes that 10% of the current is lost to parasitic affects, the starting value for the RFB resistor can be calculated from the following formula:

$$RFB(\text{starting value}) = 0.636 / I_{LAMP(RMS)}$$

$$\text{where } I_{LAMP(RMS)} = \text{nominal lamp current}$$

Overvoltage Detection Circuit Modification

The overvoltage detection circuit shown in Figure 1 does not tie the capacitor divider to ground. Instead the capacitor divider is tied through the RFB resistor to ground. This design removes some of the affect that the capacitor divider has on the lamp-current measurement. With the capacitor tied to ground through the RFB resistor, the divide ratio is set higher to help mitigate the affect of the varying low-side reference. To compensate for the low divide ratio, an additional resistor-divider is needed to properly set the overvoltage limit

which is controlled by the DS3882. In Figure 1 the capacitor divider is set to 101:1 and the resistor-divider is set to 21:1. These settings make the overvoltage limit 2121Vpk or 1500V_{RMS}, since the overvoltage threshold in the DS3882 is 1.0Vpk.

Lowpass Filter Added to the LCM and OVD Inputs

The application includes a lowpass filter on each of the DS3882's LCM and OVD inputs. When the lamp current is sensed on the low-voltage side of the lamps, this filter is not necessary. However, high-frequency ripple can occur when the current is sensed on the low-voltage side of the transformer secondary. As Figure 1 shows, the lowpass filter is comprised of the series 8.2k Ω resistor and the 120pF shunt capacitor.

Both DS3882 Channels in Phase

The DS3882 has a special mode which will place both channels in phase instead of the normal operation where channel 2 lags channel 1 by 90 degrees. Setting bit 3 of the EMIC register (address = F6h) to a 1 will force both channels in phase. Operating both channels in phase results in better current balance between the two lamps, as there will be less current loss due to the capacitance between the two adjacent lamps.

Typical Waveforms

Figures 2 through 5 are typical waveforms captured when the DS3882 drives an LCD panel with two adjacent CCFL lamps sharing a common return. Figure 2 graphs the noise that exists across the RFB resistor. Figure 3 illustrates how the lowpass filter helps remove the noise to determine the true lamp-current signal. Figure 4 shows the middle of the capacitor divider before the resistor-divider, and Figure 5 shows the signal at the OVD input on the DS3882.

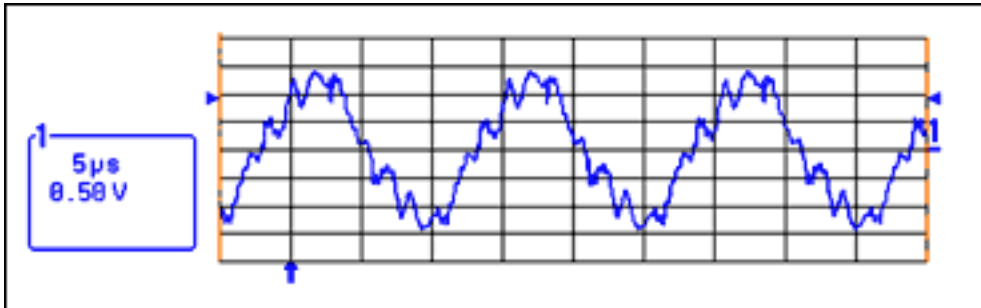

Figure 2. Lamp-current feedback resistor (RFB).

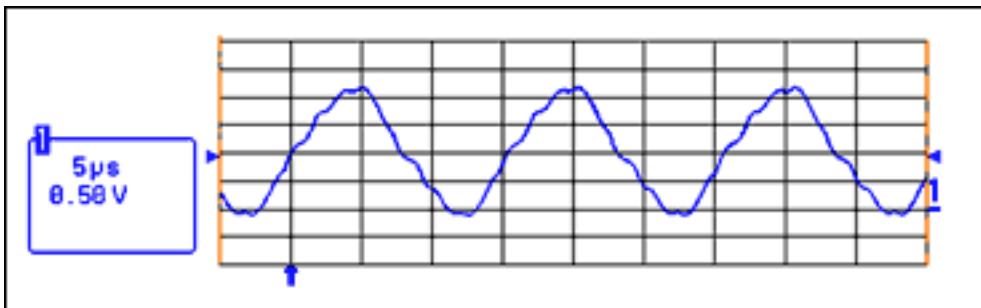

Figure 3. The DS3882's LCM input.

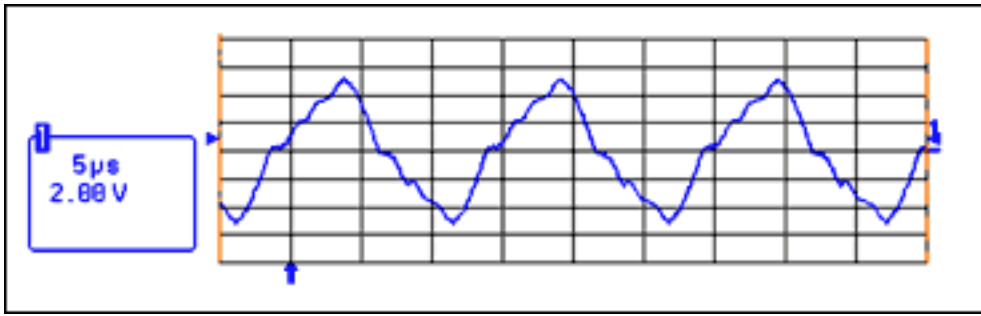

Figure 4. Lamp overvoltage capacitor divider before the resistor-divider.

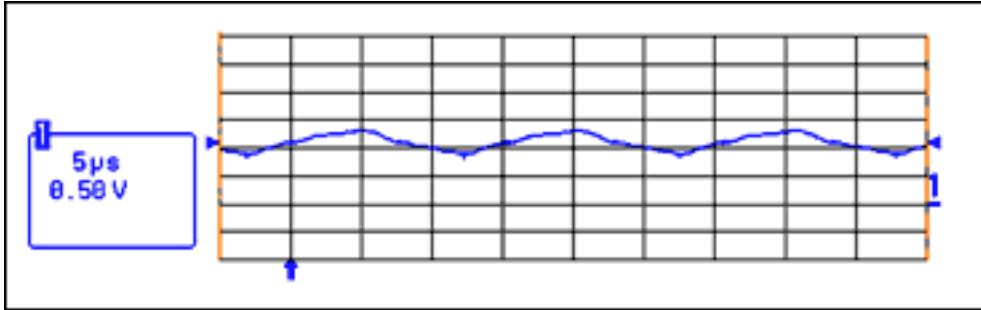

Figure 5. The DS3882's OVD input.

A similar article appeared in the September 2007 issue of *Power Electronics Technology* magazine.

Application Note 4048: www.maxim-ic.com/an4048

More Information

For technical support: www.maxim-ic.com/support

For samples: www.maxim-ic.com/samples

Other questions and comments: www.maxim-ic.com/contact

Automatic Updates

Would you like to be automatically notified when new application notes are published in your areas of interest?
[Sign up for EE-Mail™.](#)

Related Parts

DS3882: [QuickView](#) -- [Full \(PDF\) Data Sheet](#)

AN4048, AN 4048, APP4048, Appnote4048, Appnote 4048

Copyright © by Maxim Integrated Products

Additional legal notices: www.maxim-ic.com/legal