

APPLICATION NOTE 4028

How to Level Shift Video Signals for DC-Coupled Video Amplifiers/ Filters

Abstract: This application note describes a method to level shift a -0.3V to 0.7V video signal to 0 to 1V.

Maxim offers chips for filtering and amplifying analog video signals. Many of these chips are designed to be connected to the output of a video digital-to-analog converter (DAC).

To characterize the video performance of these video amplifiers/filters, standard video test signals such as color bars are applied. Although the video test signals from most video test-pattern generators range between -0.3V and 0.7V, many Maxim chips expect a video signal between 0 and 1V. The simple circuit shown in **Figure 1** can level shift the output of the video test generator so that the resulting signal is between 0 and 1V.

The circuit consists of a first amplifier with a gain of -1, followed by a second amplifier in a gain of -2. Hence, the total gain is +2. By moving the wiper of the potentiometer connected to the noninverting input on the second amplifier, the output DC level can be adjusted.

The input termination resistance of the level-shift circuit in Figure 1 is still approximately 75Ω . This is because the parallel combination of the 100Ω resistor to ground and the 300Ω input resistance of the inverting amplifier is 75Ω .

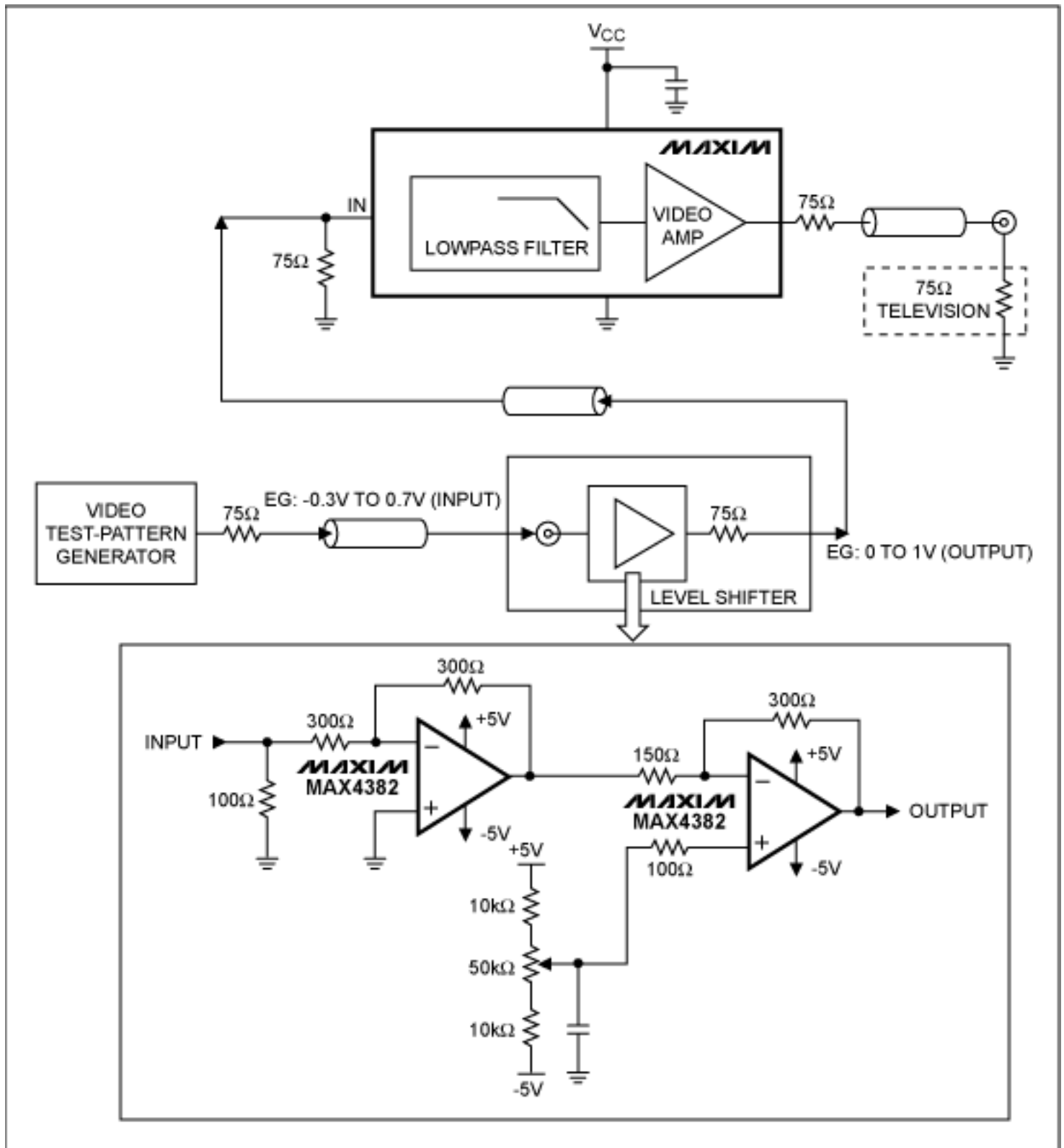

Figure 1. Implementation of a level shifter.

Figure 2 shows a standard NTSC composite test-video signal (color-bar signal generated with a Tektronix 1910 digital generator), to which a DC offset is added.

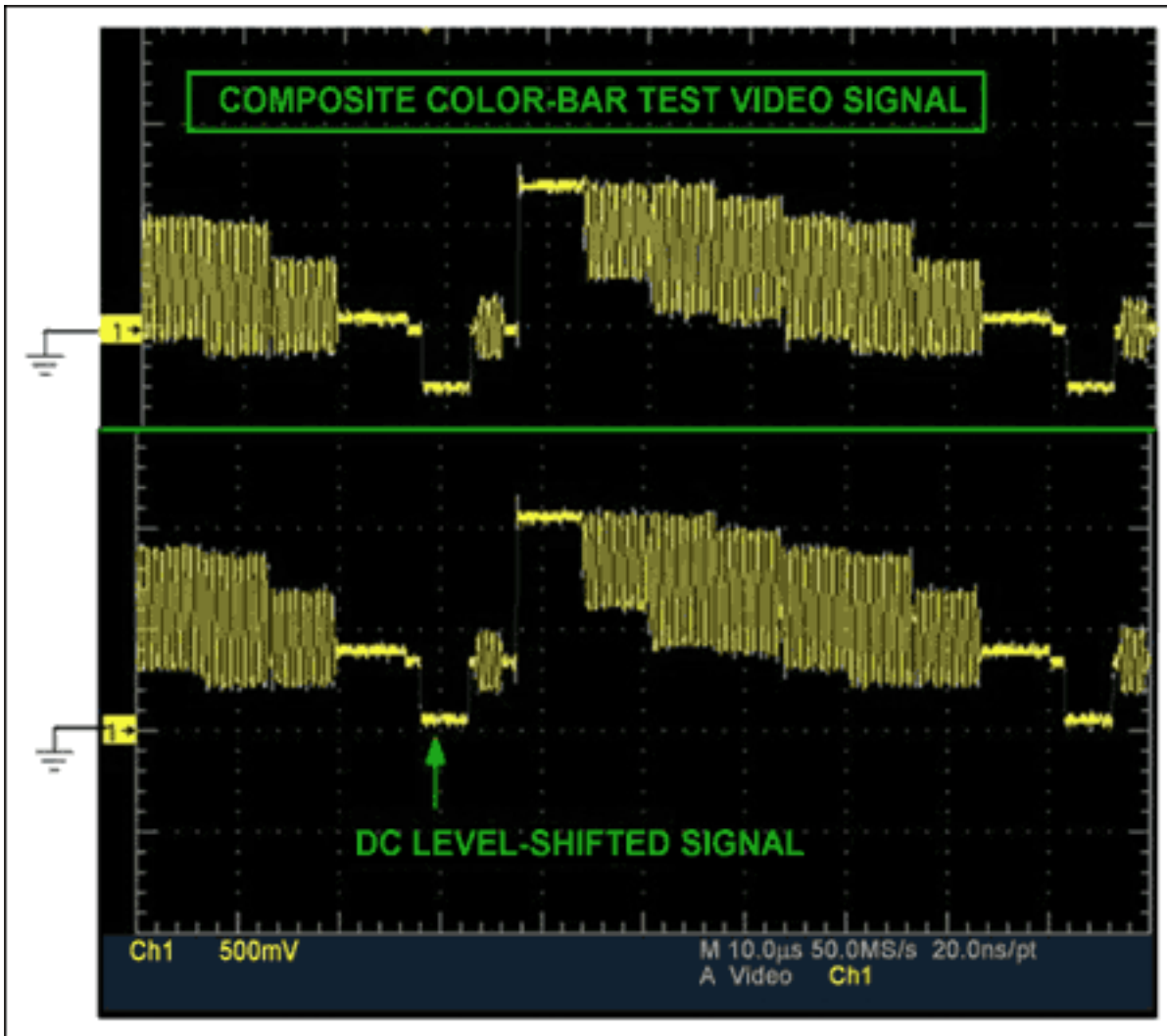

Figure 2. Composite color-bar test video signal.

Figure 3 shows the component S-video signals, both luma and chroma (color bar generated with a Quantum Data 802 BT video test generator), to which an offset voltage is added to level shift the test signal.

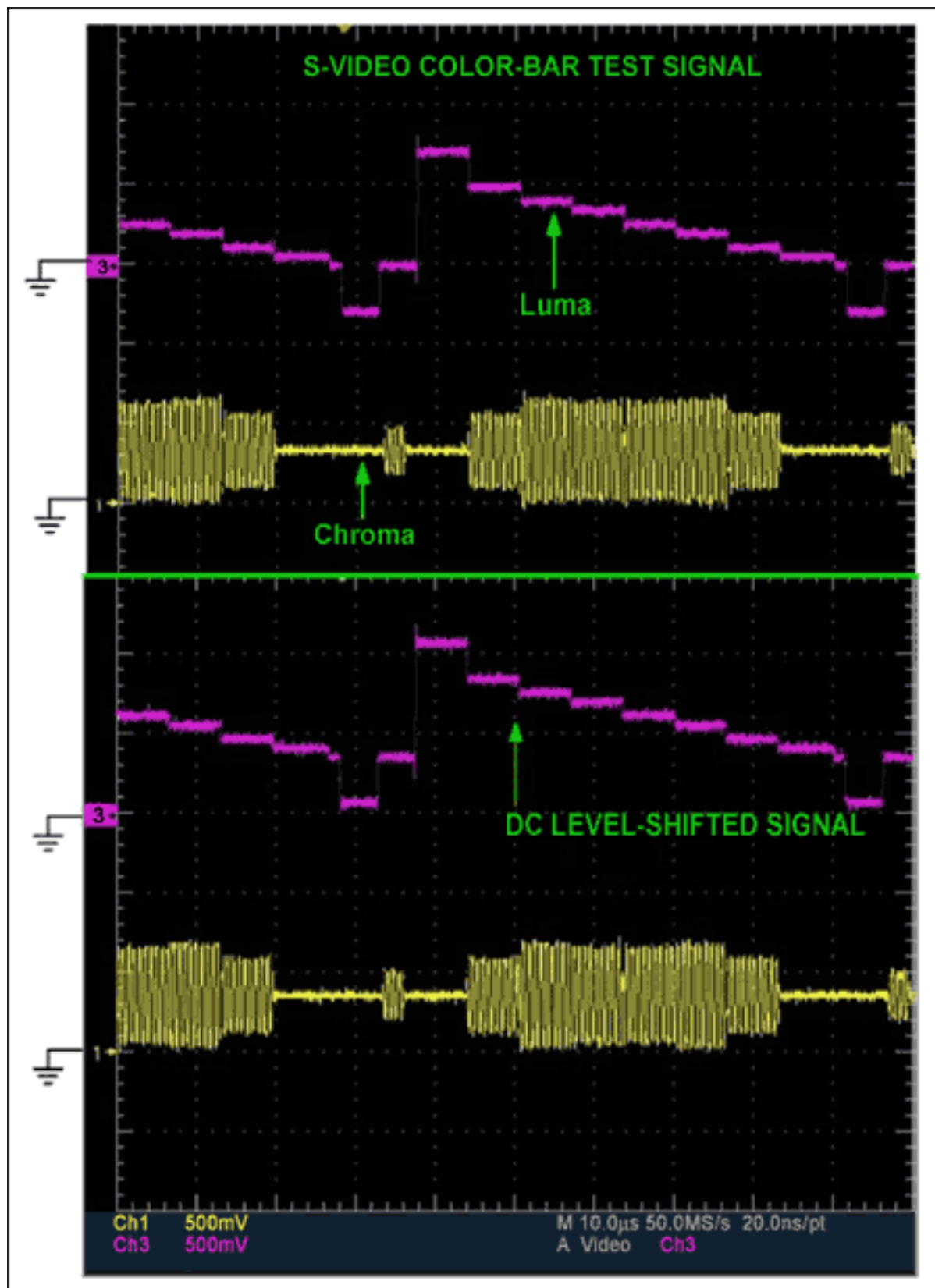

Figure 3. An S-video color-bar test video signal.

Figure 4 shows the 1080i format test signal (generated with a Quantum Data 802 BT video test generator), to which an offset voltage is added to level shift the test signal.

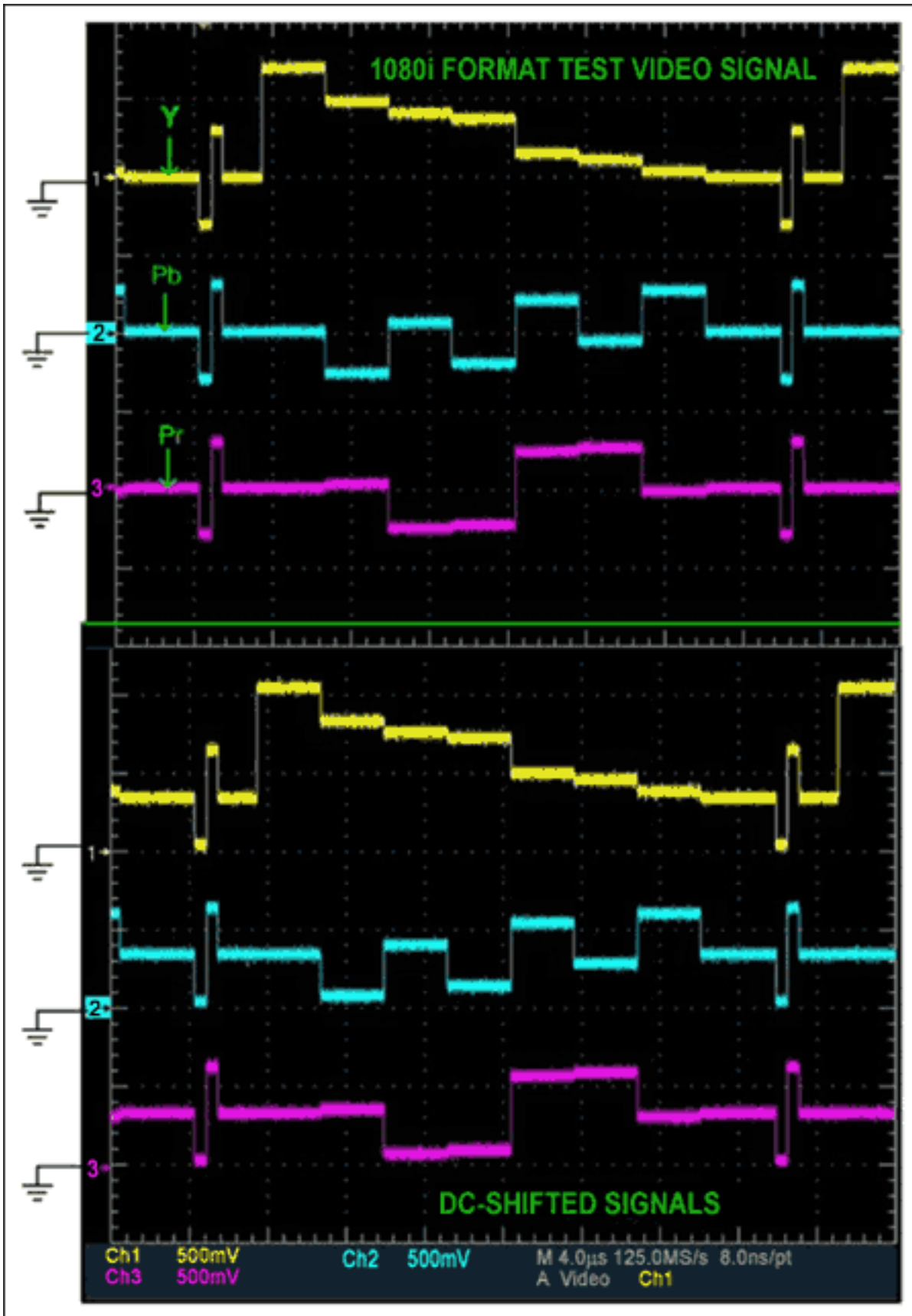

Figure 4. 1080i format test video signal.

Application Note 4028: <http://www.maxim-ic.com/an4028>

More Information

For technical questions and support: <http://www.maxim-ic.com/support>

For samples: <http://www.maxim-ic.com/samples>

Other questions and comments: <http://www.maxim-ic.com/contact>

AN4028, AN 4028, APP4028, Appnote4028, Appnote 4028

Copyright © by Maxim Integrated Products

Additional legal notices: <http://www.maxim-ic.com/legal>