



APPLICATION NOTE 4022

MAX1452 Nonlinearity-Correction Application Circuit

Abstract: The MAX1452 is a high-performance analog signal conditioner that has been widely accepted and is used in a variety of industrial and automotive applications. Sensor-output nonlinearity correction is a critical requirement in some applications. Although nonlinearity correction has not been implemented in the MAX1452, it can be achieved simply by using an additional three resistors in the application circuit. This application note presents such a circuit and provides data that supports its effectiveness.

Introduction

In sensor applications that have nonlinear outputs (such as humidity sensors), it is important that the signal conditioner be able to correct the nonlinearity of the sensor output. This application note describes how to use the [MAX1452](#)—a popular low-cost, high-performance signal conditioner with on-chip flash memory, an on-chip temperature sensor, and a fully analog signal path—to correct the nonlinearity of a sensor output. Although a nonlinearity-correction function has not been implemented in the MAX1452, it can be achieved by a very simple external circuit that utilizes three additional resistors in the application circuit. Please note that this approach is only possible using the MAX1452 in bridge-voltage-drive mode and cannot be implemented in the [MAX1455](#), since bridge-drive mode is not possible in the MAX1455.

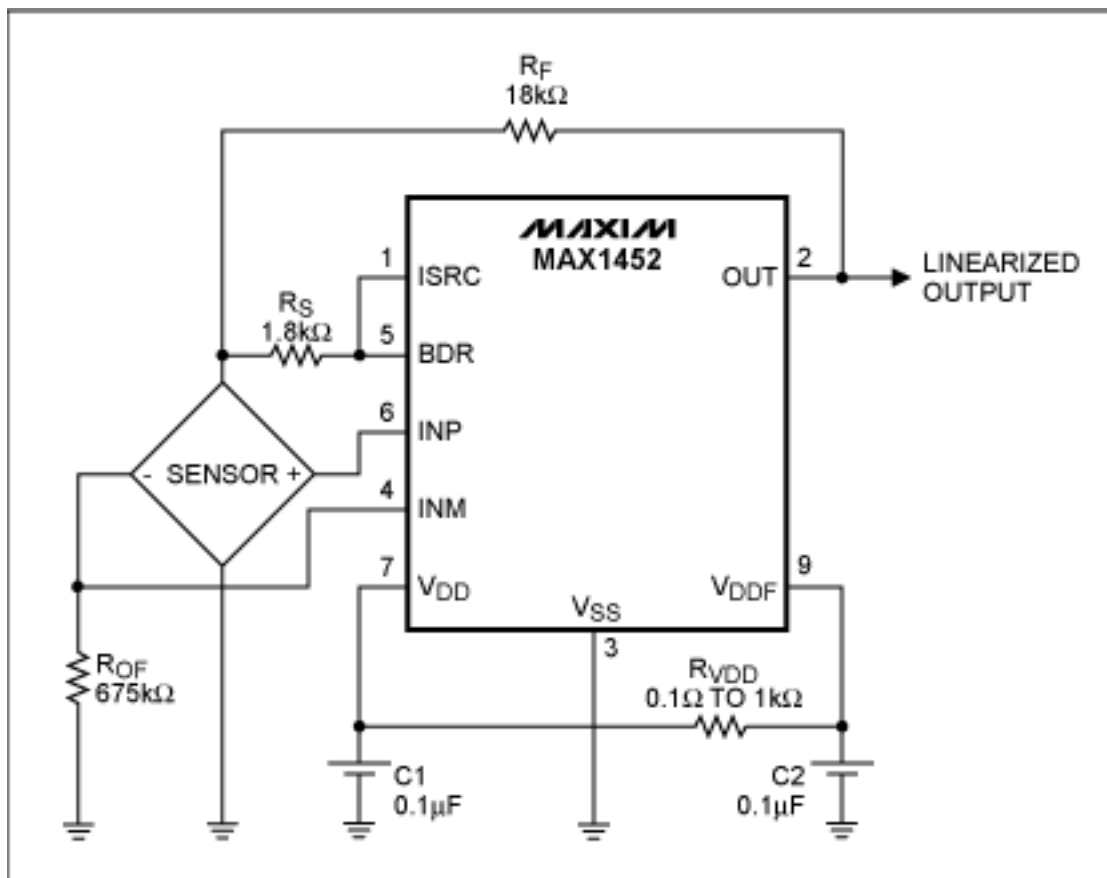

Figure 1. Basic nonlinearity-correction circuit.

Implementing a Nonlinearity-Correction Circuit

Figure 1 illustrates the circuit required for implementing nonlinearity correction in the MAX1452. In this linearizing circuit, the principle of operation is that the excitation voltage to the sensor bridge is modulated by the amplified output voltage from the OUT pin. As OUT goes high with increasing output from the sensor, the excitation on the bridge increases slightly, creating a nonlinear transfer function.

The values of $R_F = 18k\Omega$ and $R_S = 1.8k\Omega$ were selected for bridge resistances of $4.7k\Omega$ nominal. R_{OF} is added to shift the bridge output to a positive value over the whole range of the application. Based on the transfer function of the feedback circuit, R_{OF} is required to ensure that the differential output of the bridge is always positive: $INP - INM > 0$.

In the example circuit and sensor presented in this application note, the parameters were set as follows. The BDR voltage (which is the direct output of the voltage set by the FSO DAC) is set to 3.6V nominal. This produces a bridge-drive voltage of approximately 2.6V due to BDR voltage divided between R_S and the sensor bridge. The PGA gain is set to create enough gain in the system for the OUT pin to swing from 0.5V to 4.5V over 0 to 100% of the differential bridge output in the application. These values can be adjusted to suit the particular bridge offset, bridge sensitivity, and output range required by the application.

Summary of Results

The sensor used in this experiment had a linear output. So, applying the circuit above on a linear input (the input to the MAX1452) will make the output nonlinear, as presented in **Figure 2**. Figure 2 shows how changing the value of the R_F resistor affects the linearity of the output signal. In the graph, the baseline curve is the output without a feedback resistor, $R_F = \text{open}$, and no nonlinearity correction. When R_F is installed, contribution from the feedback resistor increases as the value of R_F decreases. In application, the bridge output is nonlinear and contribution from this circuit linearizes the output. Note that this circuit only corrects negative nonlinearity. No oscillation or other anomalies were noted due to this circuit.

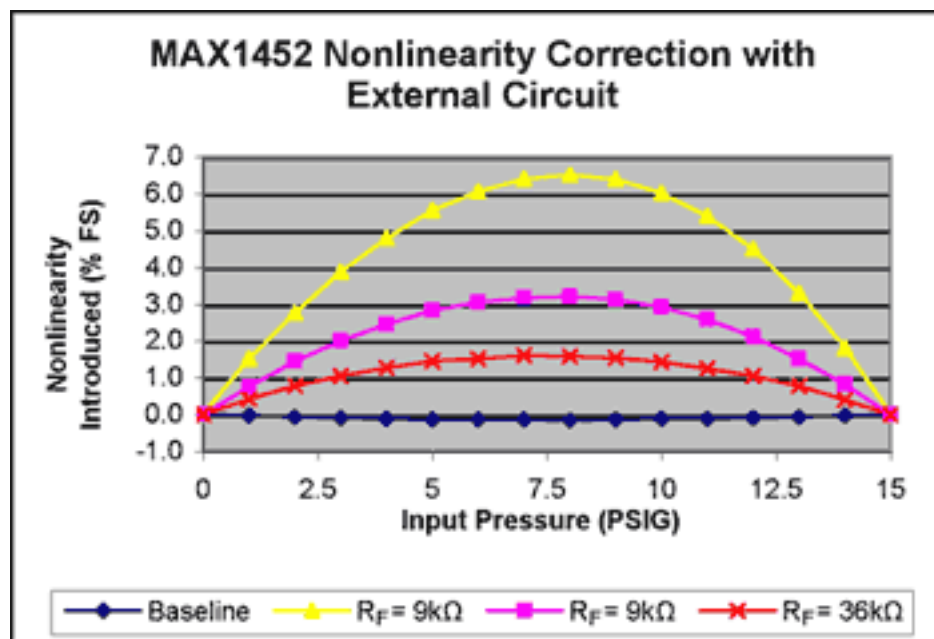

Figure 2. This graph illustrates how changing the value of the R_F resistor affects the linearity of the output signal.

References:

[MAX1452 Datasheet](#)

[MAX1452 User Manual](#)

[MAX1452 EVKit Software](#)

Application Note 4022: <http://www.maxim-ic.com/an4022>

More Information

For technical questions and support: <http://www.maxim-ic.com/support>

For samples: <http://www.maxim-ic.com/samples>

Other questions and comments: <http://www.maxim-ic.com/contact>

Related Parts

MAX1452: [QuickView](#) -- [Full \(PDF\) Data Sheet](#) -- [Free Samples](#)

MAX1455: [QuickView](#) -- [Full \(PDF\) Data Sheet](#) -- [Free Samples](#)

AN4022, AN 4022, APP4022, Appnote4022, Appnote 4022

Copyright © by Maxim Integrated Products

Additional legal notices: <http://www.maxim-ic.com/legal>