

APPLICATION NOTE 4003

Series or Shunt Voltage Reference?

Abstract: This article describes some simple steps in choosing between types of voltage references. Explanations of key parameters to use in the selection process between series- and shunt-type voltage references are presented.

Series Reference

A series reference has three terminals: V_{IN} , V_{OUT} , and GND. Though similar in concept to a linear voltage regulator, it is designed for lower current and higher accuracy. A series reference operates in series with the load (**Figure 1**), and can be regarded as a voltage-controlled resistance between the V_{IN} and V_{OUT} terminals. It regulates by adjusting its internal resistance such that V_{IN} minus the drop across the internal resistance equals the reference voltage at V_{OUT} . Because current flow is necessary to generate a voltage drop, the device draws a small quiescent current to ensure regulation when the load is removed. Series references have the following characteristics:

- The power-supply voltage (V_{CC}) must be high enough to allow a voltage drop across the internal resistance, but not high enough to damage the reference IC.
- The IC and its package must handle power dissipation in the series pass element.
- With no load current, the only source of power dissipation is the reference IC's quiescent current.
- Series references generally have a better initial tolerance and temperature coefficient than do shunt references.

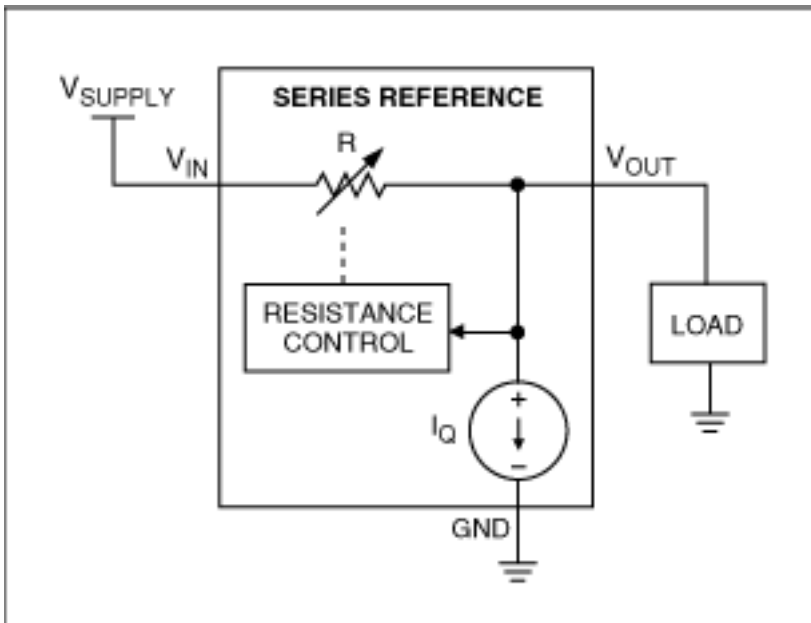

Figure 1. Block diagram of the 3-terminal series voltage reference.

Design Equations for the Series Reference

A series reference design is fairly easy. Just make sure the input voltage and power dissipation are within the maximums specified for the IC:

$$P_{\text{SER}} = (V_{\text{SUP}} - V_{\text{REF}})I_{\text{L}} + (V_{\text{SUP}} \times I_{\text{Q}})$$

For a series reference, the worst-case power dissipation occurs for maximum power-supply voltage and maximum load:

$$\text{WC_P_SER} = (V_{\text{MAX}} - V_{\text{REF}})I_{\text{L_MAX}} + (V_{\text{MAX}} \times I_{\text{Q}})$$

where:

P_{SER} = power in series reference

V_{SUP} = power-supply voltage

V_{REF} = reference output voltage

I_{L} = load current

I_{Q} = reference quiescent current

WC_P_SER = worst-case power in series reference

V_{MAX} = maximum power-supply voltage

$I_{\text{L_MAX}}$ = maximum load current

Shunt Reference

A shunt reference has two terminals, OUT and GND. It is similar in concept to a zener diode, but has much better specifications. Like a zener diode, it requires an external resistor and operates in parallel with its load (**Figure 2**). It can be regarded as a voltage-controlled current source between the OUT and GND terminals. Regulation is achieved by adjusting the current level so that V_{SUPPLY} minus the drop across R1 equals the reference voltage at OUT. As an alternate description, the shunt reference maintains a constant voltage at OUT by forcing the sum of load current and current through the reference to be constant. Shunt references have these characteristics:

- Given an R1 appropriately sized for power dissipation, the shunt reference imposes no limit on the maximum power-supply voltage.
- The power supply delivers the same maximum current regardless of load. Supply current flows through load and reference, dropping just the right voltage across R1 to maintain the OUT reference voltage.
- As a simple 2-terminal device, the shunt regulator can be used in novel circuit configurations such as negative regulators, floating regulators, clipping circuits, and limiting circuits.
- Shunt references generally have lower operating currents than do series references.

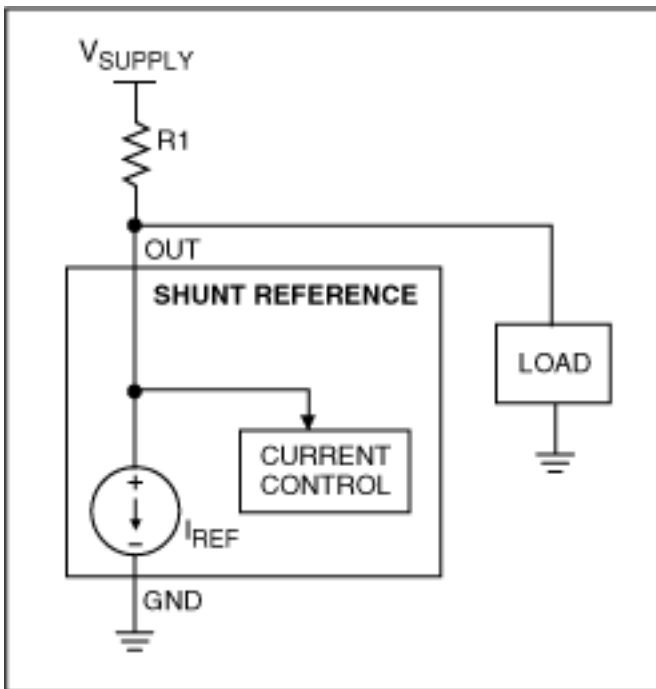

Figure 2. Block diagram of the 2-terminal shunt voltage reference.

Design Equations for the Shunt Reference

A shunt reference design is somewhat more difficult because you must calculate the external resistor value. That value ($R1$) must ensure that its voltage drop due to reference and load currents equals the difference between supply voltage and reference voltage. $R1$ must be calculated at minimum supply voltage and maximum load current to ensure operation under this worst-case condition. The following equations calculate the value and power dissipation of $R1$, and power dissipation in the shunt reference (**Figure 3**).

$$R1 = (V_{MIN} - V_{REF}) / (I_{MO} + I_{LMAX})$$

The current and power dissipation in $R1$ depend only on the power-supply voltage. Load current has no effect, because the sum of currents through load and reference is constant:

$$I_{R1} = (V_{SUP} - V_{REF}) / R1$$

$$P_{R1} = (V_{SUP} - V_{REF})^2 / R1$$

$$P_{SHNT} = V_{REF}(I_{MO} + I_{R1} - I_L)$$

The worst-case conditions are maximum power-supply voltage and no load:

$$WC_{I_{R1}} = (V_{MAX} - V_{REF}) / R1$$

$$WC_{P_{R1}} = (V_{MAX} - V_{REF})^2 / R1$$

$$WC_{P_{SHNT}} = V_{REF}(I_{MO} + WC_{I_{R1}})$$

or

$$WC_{P_{SHNT}} = V_{REF}(I_{MO} + (V_{MAX} - V_{REF}) / R1)$$

where:

$R1$ = external resistor

I_{R1} = current flowing through $R1$

P_{R1} = power dissipation in $R1$

P_{SHNT} = power dissipation in shunt reference

V_{MIN} = minimum power-supply voltage

V_{MAX} = maximum power-supply voltage

V_{REF} = reference output voltage

I_{MO} = reference minimum operating current

$I_{L_{MAX}}$ = maximum load current

$WC_{I_{R1}}$ = worst-case current through R1

$WC_{P_{R1}}$ = worst-case power dissipation in R1

$WC_{P_{SHNT}}$ = worst case power dissipation in shunt reference

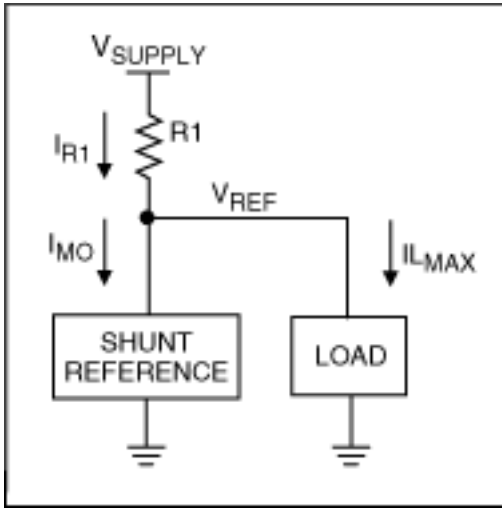

Figure 3. A shunt reference in this configuration varies its current (I_{MO}) to produce a constant V_{REF} .

Choosing a Reference

Now that you understand the differences between a series and shunt reference, the next step is to determine which is better for your application. The best way to make sure you are getting a suitable part is to consider both the series and shunt types. After doing the design calculations for each, the preferred type should be obvious. Here are some rules of thumb:

- If you need better than 0.1% initial accuracy and a 25ppm temperature coefficient, you should probably select a series reference.
- If you want the lowest operating current, consider a shunt reference.
- Be careful when combining a shunt reference with a widely varying power supply or load. Be sure to calculate the expected power dissipation, which can be much higher than that of an equivalent series reference. (See examples, which follow.)
- For power-supply voltages higher than 40V, a shunt reference may be your only choice.
- Consider shunt references when building a negative reference, floating reference, clipping circuit, or limiting circuit.

Example 1—Low Voltage, Steady Load

In this portable application, the most critical parameter is low power dissipation. These are the specifications:

$$V_{MAX} = 3.6V$$

$$V_{MIN} = 3.0V$$

$$V_{REF} = 2.5V$$

$$I_{L_{MAX}} = 1\mu A$$

We have narrowed the search to two parts, as follows:

MAX6029 Series Reference

$$I_Q = 5.75\mu\text{A}$$

$$WC_P_SER = (V_{MAX} - V_{REF})I_{L_MAX} + (V_{MAX} \times I_Q)$$

$$WC_P_SER = (3.6\text{V} - 2.5\text{V})1\mu\text{A} + (3.6\text{V} \times 5.75\mu\text{A}) = 21.8\mu\text{W}$$

The series reference is the only part that dissipates power in this circuit, so the total worst-case power dissipation is 21.8 μ W.

MAX6008 Shunt Reference

$$I_{MO} = 1\mu\text{A}$$

$$R1 = (V_{MIN} - V_{REF}) / (I_{MO} + I_{L_MAX})$$

$$R1 = (3.0\text{V} - 2.5\text{V}) / (1\mu\text{A} + 1\mu\text{A}) = 250\text{k}\Omega$$

$$WC_I_R1 = (V_{MAX} - V_{REF}) / R1$$

$$WC_I_R1 = (3.6\text{V} - 2.5\text{V}) / 250\text{k}\Omega = 4.4\mu\text{A}$$

$$WC_P_R1 = (V_{MAX} - V_{REF})^2 / R1$$

$$WC_P_R1 = (3.6\text{V} - 2.5\text{V})^2 / 250\text{k}\Omega = 4.84\mu\text{W}$$

$$WC_P_SHNT = V_{REF}(I_{MO} + (V_{MAX} - V_{REF}) / R1)$$

$$WC_P_SHNT = 2.5\text{V} (1\mu\text{A} + (3.6\text{V} - 2.5\text{V}) / 250\text{k}\Omega) = 13.5\mu\text{W}$$

Total worst-case power dissipation for this circuit is the sum of the worst-case power dissipations in R1 (WC_P_R1) plus the worst-case power in the shunt reference (WC_P_SHNT), which equals 18.3 μ W.

The preferred part for this application is the MAX6008 shunt reference, because its power dissipation is 18.3 μ W (vs. 21.8 μ W for the MAX6029 series reference). This example illustrates the large effect of power-supply variation on design. Initially it appeared that the shunt reference had a huge advantage with its 1 μ A minimum operating current. However, to guarantee operation under worst-case conditions, the operating current had to be increased to 4.4 μ A. Any variation in the power-supply voltage greater than specified in this case (3.0V to 3.6V) would call for the use of a series reference.

Example 2—Low Voltage, Varying Load

This example is similar to Example 1, but with a small change in the specifications. Instead of a steady 1 μ A load, this load alternately draws 1 μ A for 99ms, then 1mA for 1ms.

$$V_{MAX} = 3.6\text{V}$$

$$V_{MIN} = 3.0\text{V}$$

$$V_{REF} = 2.5\text{V}$$

$$I_{L_MAX} = 1\text{mA} \text{ (1\% of time)}$$

$$I_{L_MIN} = 1\mu\text{A} \text{ (99\% of time)}$$

We consider the same two parts:

MAX6029 Series Reference

$$I_Q = 5.75\mu\text{A}$$

$$WC_P_SER = (V_{MAX} - V_{REF})I_{L_MAX} + (V_{MAX} \times I_Q)$$

$$WC_P_SER \text{ (1mA IL)} = (3.6\text{V} - 2.5\text{V})1\text{mA} + (3.6\text{V} \times 5.75\mu\text{A})$$

$$\begin{aligned} &= 1.12\text{mW (1\% of time)} \\ \text{WC_P_SER (1}\mu\text{A IL)} &= (3.6\text{V} - 2.5\text{V})1\mu\text{A} + (3.6\text{V} \times 5.75\mu\text{A}) \\ &= 21.8\mu\text{W (99\% of time)} \end{aligned}$$

$$\text{Average power dissipation} = 1.12\text{mW} \times 1\% + 21.8\mu\text{W} \times 99\% = 32.78\mu\text{W}$$

MAX6008 Shunt Reference

$$I_{\text{MO}} = 1\mu\text{A}$$

$$R1 = (V_{\text{MIN}} - V_{\text{REF}})/(I_{\text{MO}} + I_{\text{LMAX}})$$

$$R1 = (3.0\text{V} - 2.5\text{V})/(1\mu\text{A} + 1\text{mA}) = 499\Omega$$

For $I_{\text{LOAD}} = 1\text{mA}$:

$$\text{WC_P_R1} = (V_{\text{MAX}} - V_{\text{REF}})^2/R1$$

$$\text{WC_P_R1} = (3.6\text{V} - 2.5\text{V})^2/499\Omega = 2.42\text{mW (1\% of time)}$$

$$P_{\text{SHNT}} = V_{\text{REF}}(I_{\text{MO}} + I_{\text{R1}} - I_{\text{L}})$$

$$P_{\text{SHNT}} = 2.5\text{V}(1\mu\text{A} + 1\text{mA} - 1\text{mA}) = 2.5\mu\text{W (1\% of time)}$$

For $I_{\text{LOAD}} = 1\mu\text{A}$:

$$\text{WC_P_R1} = (V_{\text{MAX}} - V_{\text{REF}})^2/R1$$

$$\text{WC_P_R1} = (3.6\text{V} - 2.5\text{V})^2/499\Omega = 2.42\text{mW (99\% of time)}$$

$$P_{\text{SHNT}} = V_{\text{REF}}(I_{\text{MO}} + I_{\text{R1}} - I_{\text{L}})$$

$$P_{\text{SHNT}} = 2.5\text{V}(1\mu\text{A} + 1\text{mA} - 1\mu\text{A}) = 2.5\text{mW (99\% of time)}$$

$$\text{Average power dissipation is } 2.42\text{mW} \times 1\% + 2.5\mu\text{W} \times 1\% + 2.42\text{mW} \times 99\% + 2.5\text{mW} \times 99\% = 4.895\text{mW}.$$

As you can see, the average power dissipation in the shunt reference is over 100 times higher than in the series reference. For applications in which the load current varies widely, a series reference is usually the better choice.

A similar article appeared on the [Planet Analog](#) website in May of 2006.

Application Note 4003: www.maxim-ic.com/an4003

More Information

For technical questions and support: www.maxim-ic.com/support

For samples: www.maxim-ic.com/samples

Other questions and comments: www.maxim-ic.com/contact

Keep Me Informed

Preview new application notes in your areas of interest as soon as they are published. Subscribe to [EE-Mail - Application Notes](#) for weekly updates.

AN4003, AN 4003, APP4003, Appnote4003, Appnote 4003

Copyright © by Maxim Integrated Products

Additional legal notices: www.maxim-ic.com/legal