

Keywords: 1-wire, 1wire, interface, ibutton, overview, memory, security, control, single contact

Feb 09, 2007

## APPLICATION NOTE 3989

# Add Control, Memory, Security, and Mixed-Signal Functions with a Single Contact

*Abstract: This application note provides a high-level overview of the 1-Wire® interface. It discusses power and data delivery along with data-bit-level communication, device selection, and the unalterable, unique ID in each device. As its name implies, the single-contact 1-Wire interface is an unmatched solution that provides key functions to systems where interconnect must be minimized.*

## Overview

The Maxim 1-Wire bus is a simple signaling scheme that performs half-duplex bidirectional communications between a host/master controller and one or more slaves sharing a common data line (Figure 1). Both power and data communication for slave devices are transmitted over this single 1-Wire line. For power delivery, slaves capture charge on an internal capacitor when the line is in a high state and then use this charge for device operation when the line is low during data transmission. A typical 1-Wire master consists of an open-drain I/O port pin and a 3V to 5V resistor pullup. More sophisticated masters, including dedicated line-driver solutions, are available from Maxim. This clever communication scheme also allows you to add memory, authentication, and mixed-signal functions at any time, easily and efficiently.

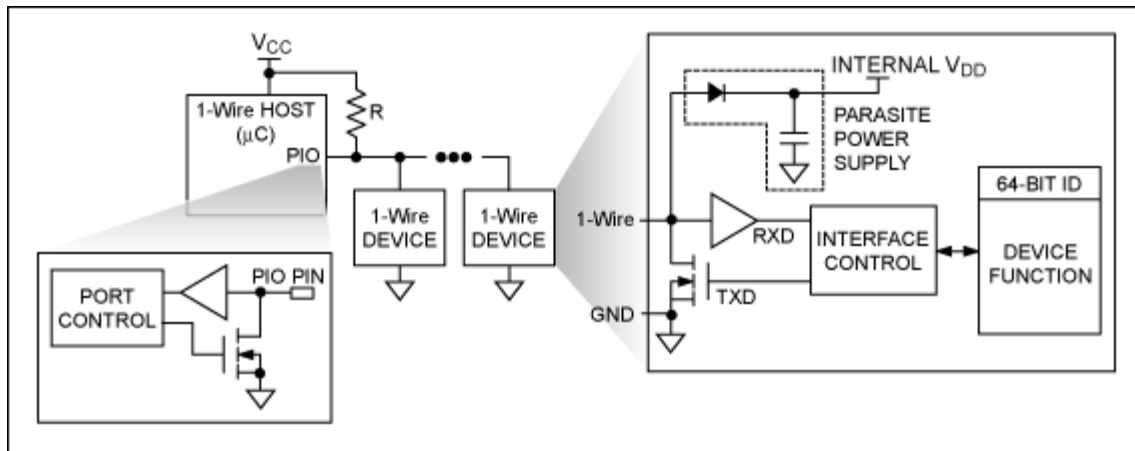

Figure 1. In a 1-Wire master/slave configuration, all devices share a common data line.

## 64-Bit Serial Numbers

There is an important, fundamental feature in every 1-Wire system: each slave device has a unique, unalterable (ROM), 64-bit, factory-lasered serial number (ID) that will never be repeated in another device. Besides providing a unique electronic ID to the end product, this 64-bit ID value allows the master device to select a slave device among the many that can be connected to the same bus wire. Part of the 64-bit ID is also an 8-bit family code that identifies the device type and functionality supported.

## Data-Bit-Level Communication

The bus master initiates and controls all 1-Wire communication. As illustrated in Figure 2, the 1-Wire communication waveform is similar to pulse-width modulation, because data is transmitted by wide (logic 0) and narrow (logic 1) pulse widths during data-bit time periods or time slots. A communication sequence starts when the bus master drives a defined length "Reset" pulse that synchronizes the entire bus. Every slave responds to the Reset pulse with a logic-low "Presence" pulse. To write data, the master first initiates a time slot by driving the 1-Wire line low, and then either holds the line low (wide pulse) to transmit a logic 0 or releases the line (short pulse) to allow the bus to return to the logic 1 state. To read data, the master again initiates a time slot by driving the line with a narrow low pulse. Slaves can then either return a logic 0 by turning on the open-drain output and holding the line low to extend the

pulse, or a logic 1 by leaving the open-drain output off to allow the line to recover. Most 1-Wire devices support two data rates: Standard speed of about 15kbps and Overdrive speed of about 111kbps. The protocol is self-clocking and tolerates long inter-bit delays, which ensures smooth operation in interrupted software environments.

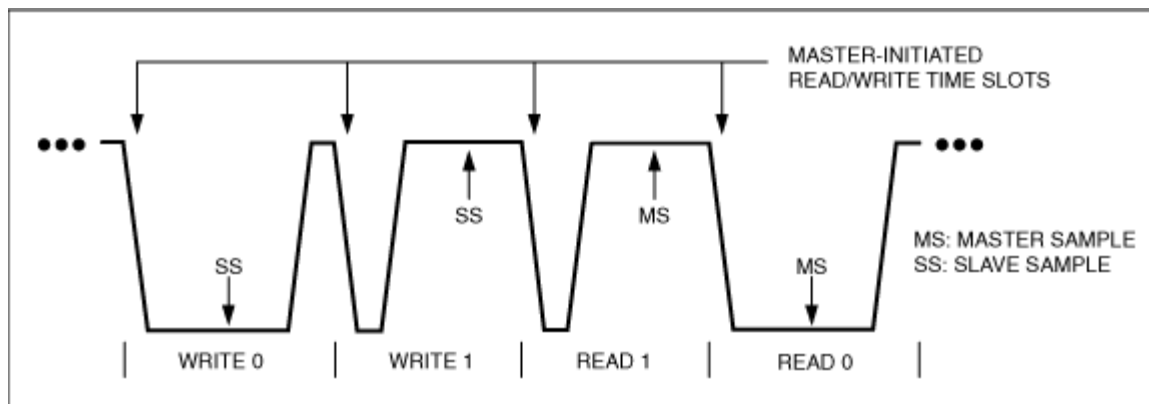

Figure 2. This waveform example shows master-initiated write/read of data bits with slave and master sampling points.

## Device Selection

The first action in a 1-Wire communication is selecting a slave device for subsequent communications. In a single slave-device environment, the selection sequence is minimal. In a multidevice environment, however, slave selection is done either by selecting all slaves or a specific slave targeted by its 64-bit ID. A binary search algorithm (described as ROM-level commands in the 1-Wire literature) "learns" and subsequently selects the respective 64-bit IDs of all slave devices on the line. When a specific slave is selected, the master issues device-specific commands and sends data to it, or reads data from it. Meanwhile, all the other slave devices ignore communications until the next reset pulse is issued.

## Summary

You can layer a variety of memory, digital, analog, and mixed-signal functions onto a 1-Wire communication system. The resulting diverse product portfolio will definitely solve interconnect limitations in a constrained design and/or add value with unique product features. The 1-Wire products are available in standard IC packaging and the Company's rugged, stainless steel iButton® package. Products, packaging, and extensive software support are detailed at: [1-Wire](#). For a more text-oriented presentation of 1-Wire devices, see application note 1796, "[Overview of 1-Wire Technology and Its Use](#)." Maxim's 1-Wire products have more than 15 years of history in the medical field. Application note 4702, "[Easily Add Memory, Security, Monitoring, and Control to Medical Sensors and Consumables](#)," provides details and practical examples.

1-Wire is a registered trademark of Maxim Integrated Products, Inc.

iButton is a registered trademark of Maxim Integrated Products, Inc.

## Related Parts

DS2401	Silicon Serial Number	-- <a href="#">Free samples</a>
DS2406	Dual Addressable Switch Plus 1Kb Memory	-- <a href="#">Free samples</a>
DS2411	Silicon Serial Number with V <sub>CC</sub> Input	-- <a href="#">Free samples</a>
DS2413	1-Wire Dual Channel Addressable Switch	-- <a href="#">Free samples</a>
DS2417	1-Wire Time Chip With Interrupt	-- <a href="#">Free samples</a>
DS2431	1024-Bit 1-Wire EEPROM	-- <a href="#">Free samples</a>
DS2432	1Kb Protected 1-Wire EEPROM with SHA-1 Engine	-- <a href="#">Free samples</a>
DS2450	1-Wire Quad A/D Converter	-- <a href="#">Free samples</a>
DS2480B	Serial to 1-Wire Line Driver	-- <a href="#">Free samples</a>
DS2482-100	Single-Channel 1-Wire Master	-- <a href="#">Free samples</a>
DS2502	1Kb Add-Only Memory	-- <a href="#">Free samples</a>
DS2505	16Kb Add-Only Memory	-- <a href="#">Free samples</a>
DS28E01-100	1Kb Protected 1-Wire EEPROM with SHA-1 Engine	-- <a href="#">Free samples</a>
DS28E04-100	4096-Bit Addressable 1-Wire EEPROM with PIO	-- <a href="#">Free samples</a>

DS28EA00 1-Wire Digital Thermometer with Sequence Detect and PIO -- [Free samples](#)

DS28EC20 20Kb 1-Wire EEPROM -- [Free samples](#)

---

#### Automatic Updates

Would you like to be automatically notified when new application notes are published in your areas of interest? [Sign up for EE-Mail™](#).

---

#### More Information

For technical support: <http://www.maxim-ic.com/support>

For samples: <http://www.maxim-ic.com/samples>

Other questions and comments: <http://www.maxim-ic.com/contact>

---

Application note 3989: <http://www.maxim-ic.com/an3989>

AN3989, AN 3989, APP3989, Appnote3989, Appnote 3989

Copyright © by Maxim Integrated Products

Additional legal notices: <http://www.maxim-ic.com/legal>