



APPLICATION NOTE 3961

## TD-SCDMA RD V2.1 Design Meets Rx-Blocking Mask and Sensitivity Requirements

*Abstract: This application note introduces Maxim's 2nd-generation TD-SCDMA radio frequency transceiver chipset with its V2.1 reference design. It also discusses some of the key system issues, such as sensitivity and blocker tests, that warrant careful consideration in order to create an optimum TD-SCDMA RF design.*

### Maxim TD-SCDMA RF Transceiver Chipset

Maxim's TD-SCDMA mobile-phone RF chipset consists of the MAX2507 (Tx) and the MAX2392 (Rx). Both RF ICs are fabricated using Maxim's in-house, high-frequency process technology. The MAX2507 is a fully-integrated transmitter chip that includes circuits from analog I/Q input to power-amplifier output. Its main functional blocks include an I/Q quadrature modulator, an upconverter, a variable-gain amplifier (VGA), an RF voltage-controlled oscillator (VCO) and phase-locked loop (PLL), IF local oscillator generation, and an RF power amplifier (PA). This device is packaged in a 7mm x 7mm land grid array (LGA). The companion zero-IF receiver, the MAX2392, includes circuits from a low-noise amplifier (LNA) to analog I/Q output. Its main functional blocks include an LNA, an RF I/Q demodulator, RF VCO and PLL circuitry, baseband channel-select filters, DC-offset correction circuitry, and automatic gain control (AGC) baseband amplifiers. The MAX2392 is housed in a 5mm x 5mm QFN package. A complete reference design that facilitates the OEM radio RF board design shows an effective overall PCB size of 6.6cm<sup>2</sup>. The functional block diagram of the reference design is shown in **Figure 1** and a photograph of the reference board in **Figure 2**.

### Rx Requirements in TD-SCDMA Standard

The main Rx requirements of the TD-SCDMA standard are shown in **Table 1**. The minimum sensitivity that needs to be met is -108dBm, while the blocking spec is a canyon shape with frequency offset.

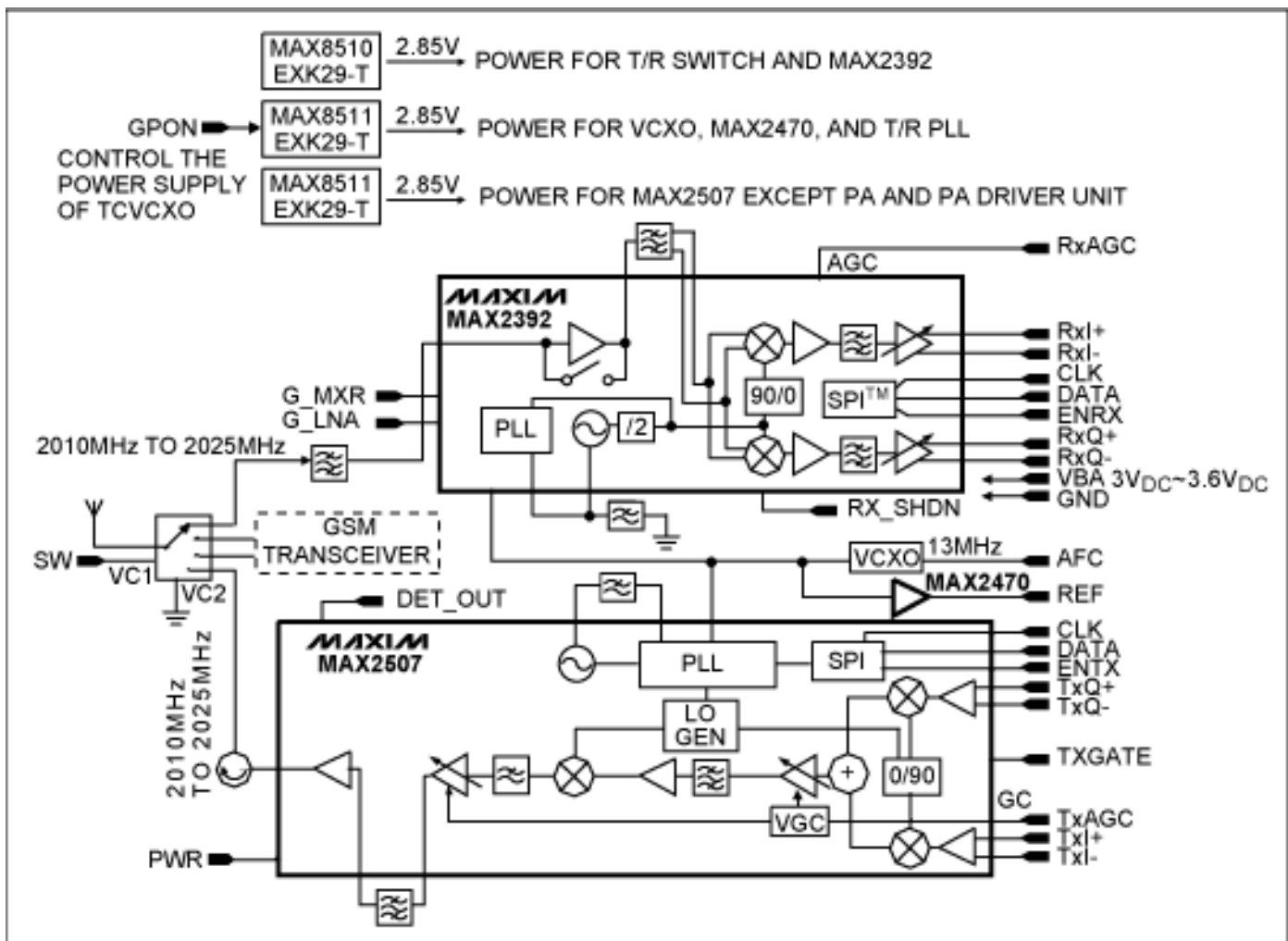

Figure 1. TD-SCDMA reference-design functional block diagram.

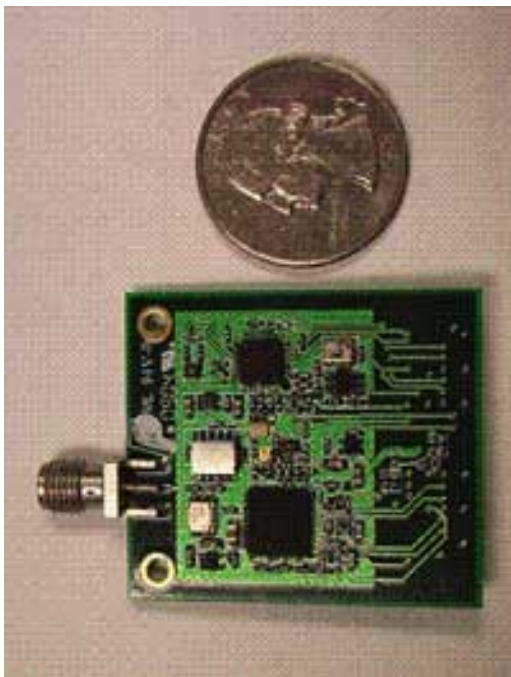

Figure 2. TD-SCDMA reference design board.

**Table 1. TD-SCDMA Rx Requirements**

General Requirements		
Description	Spec	Note
Frequency Band	2010MHz to 2025MHz	—
BER	< 0.001	—
Eb/Nt	5.2dB	<ul style="list-style-type: none"> <li>• Estimation/simulation</li> <li>• Subject to change</li> </ul>
Rx Sensitivity	-108dBm	12.2kbps data rate
Maximum Input Level	-25dBm/1.28MHz	DPCH_Ec/Ior is 7dB
Adjacent Channel Selectivity (ACS)	33dB	±1.6MHz frequency offset
Receiver System NF	< 6.8dB	Customer proposed
I and Q Output Power	1V <sub>p-p</sub> with 2kΩ loading	Customer proposed
I and Q LPF Requirements	-40dBc at 5.12MHz, -3dBc at 800kHz, Bessel response with 3° phase delay and 0.2dB amp ripple below 640kHz	<ul style="list-style-type: none"> <li>• Customer proposed</li> <li>• Design with MAX4134 op amp</li> </ul>

Blocking Requirements		
In-Band Blocking	Case 1	Case 2
Blocking Offset	±3.2MHz	±4.8MHz
Desired Signal Level	-105dBm/1.28MHz	-105dBm/1.28MHz
Undesired Signal Level (Modulated)	-61dBm/1.28MHz	-49dBm/1.28MHz

Out-of-Band Blocking				
Parameter	Band 1	Band 2	Band 3	Unit
Desired Signal Level	-105	-105	-105	dBm/1.28MHz
Undesired Signal Level (CW)	-44	-30	-15	dBm
Frequency Band	1840 < f < 1885 1935 < f < 1995 2040 < f < 2095	1815 < f < 1840 2095 < f < 2120	1 < f < 1815 2120 < f < 12750	MHz

## Sensitivity and Blocking Spec Analysis and Measured Results

Receiver sensitivity is a system specification that is very much influenced by the signal quality in the RF channel and the baseband processing in the DSP modem section. Under minimum input signal level conditions, the RF channel quality is purely limited by the receiver's noise contribution, which is determined by its noise figure (NF). Note that, under these signal conditions, receiver phase noise is not considered because its level is much smaller than that of thermal noise. Therefore, receiver phase noise has minimal impact on the degradation of the input SNR. In the 3GPP TR 25.945 standard [3], receiver sensitivity is specified at -108dBm. Based on typical baseband processing gain and desired BER after demodulation, this receiver sensitivity corresponds to a 9dB maximum receiver NF. The measured NF of the TD-SCDMA reference design receiver path, shown in Figure 1, is around 5.7dB. Hence, the corresponding measured sensitivity is -111dBm, which allows for 3dB additional margin over the standard specification.

The effects of in-band blockers on receiver performance are typically manifested in three phenomena: cross-modulation, 2nd-order intermodulation products, and reciprocal mixing, which are discussed in the following three subsections.

# Cross-Modulation

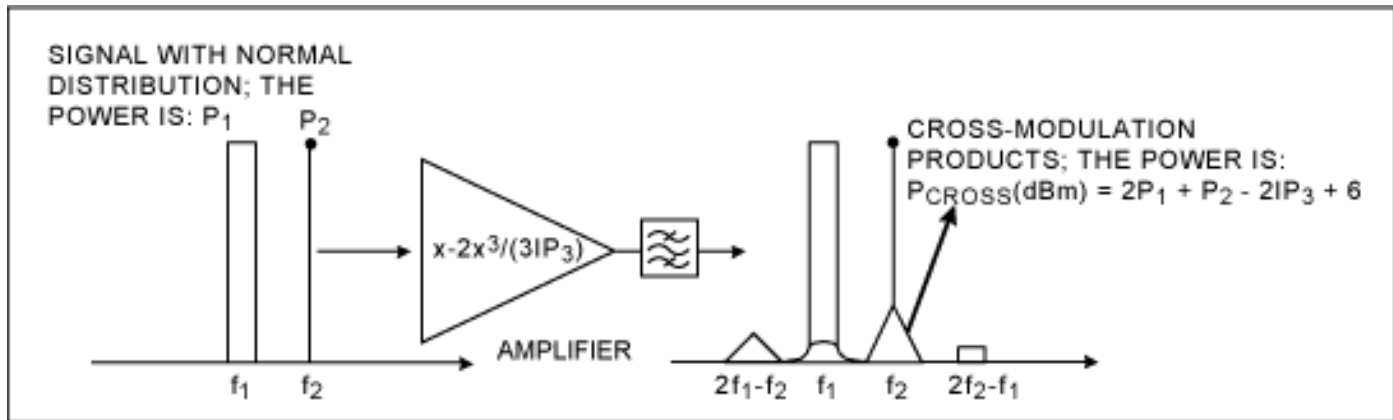

Figure 3. Cross-modulation products.

**Figure 3** shows the cross-modulation phenomenon that occurs in a nonlinear component such as an amplifier or a mixer. In the figure, the signal at  $f_1$  is a modulated blocker with a certain bandwidth, and the CW signal at  $f_2$  represents the desired signal. At the amplifier output, a triangular intermodulation product results at  $f_2$  centered around the desired signal-frequency spectrum. This cross-modulation product is typically related to the component's 3rd-order nonlinearity characteristics and, hence, its 3rd-order intercept point. When the blocking signal has a Gaussian-noise-like normal distribution, the power of the resulting cross-modulation product can be estimated using the following formula:

$$P_{X_{mod}}(dBm) = 2P_1 + P_2 - 2IIP_3 + 6 \quad (\text{Eq. 1})$$

In the case when the input signal is also modulated, the shape of the output product is the convolution of a triangle and the signal-power spectral-density function. As the blocker characteristics deviate from the Gaussian noise-like normal distribution, the cross-modulation product becomes smaller. When the interfering signal is considered as a modulated blocker with a constant envelope, the cross-modulation product is zero.

The 3GPP TDD standard specifies that 3dB degradation in sensitivity is allowed for a -49dBm modulated interferer at a  $\pm 4.8$ MHz offset. If we consider that the sensitivity degradation results solely from the cross-modulation product, this performance level is achievable as long as the power of the cross-modulation product is small in relation to the power of the receiver's in-band thermal noise at sensitivity level. Assuming that noise figure of the receiver is less than 9dB, as required by the standard, we can deduce from equation 2 the equivalent receiver's 3rd-order intercept point, as dictated by cross-modulation.

$$P_{X_{mod}}(dBm) = 2P_1 + P_2 - 2IIP_{3,RX} + 6 = 2 \times (-49) + (-105) - 2IIP_{3,RX} + 6 \leq -174 + 10\text{Log}(1.28M) + 9$$

$$\Rightarrow IIP_{3,RX}: X_{mod} \geq -47\text{dBm} \quad (\text{Eq. 2})$$

## 2nd-Order Intermodulation Products (IM2)

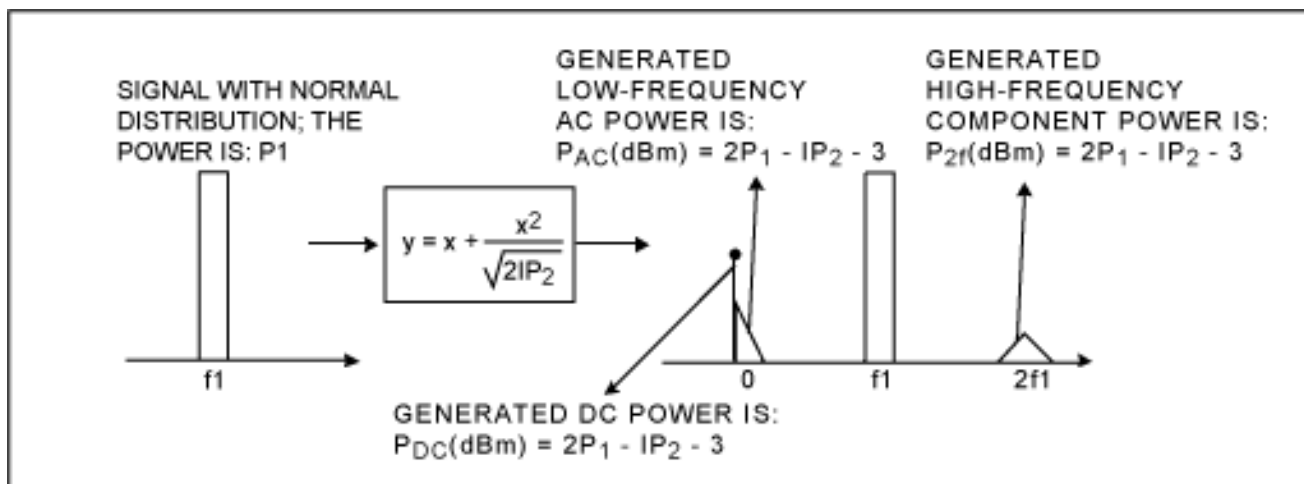

Figure 4. 2nd-order intermodulation products.

The 2nd-order intermodulation products due to a modulated blocker consist of three components, as shown in **Figure 4**: DC offset, low-frequency products around 0Hz, and products around  $2f_1$ . When the blocker's signal statistics follow a Gaussian-noise-like normal distribution, the three components are equal in power, and they can be estimated using the formulas shown in Figure 4. When the blocker's signal statistics approach those of a constant envelope signal, the power level of the low-frequency products gets minimized. When the interfering signal is a constant envelope blocker, there are no low-frequency IM2 products generated at the output. At the I/Q outputs of a zero-IF receiver, these low-frequency and DC IM2 components fall in the desired downconverted signal band and can result in receiver performance degradation. In the MAX2392 receiver circuitry, DC offsets are removed on-chip; therefore, only the low-frequency IM2 products need to be accounted for when looking at the receiver interference budget.

The 3GPP TDD standard specifies that 3dB degradation in sensitivity is allowed for a -49dBm modulated interferer at a  $\pm 4.8$ MHz offset. Similar to the cross-modulation case, if we consider that the sensitivity degradation results solely from low-frequency IM2 products, and the NF of the receiver is less than 9dB as required by the standard, we can estimate the required receiver 2nd-order intercept point,  $IIP_{2,RX}$ , as shown in equation 3. Assuming that the downconverted in-band blockers are eliminated in the post-mixer baseband channel-select filters, the receiver 2nd-order intercept point is solely dictated by that of the zero-IF downconverter block.

$$P_{AC}(dBm) = 2P_1 - IP_2 - 3 = 2 \times (-49) - IP_{2,RX} - 3 \leq -174 + 10\text{Log}(1.28\text{M}) + 9 \quad (\text{Eq. 3})$$

$$\Rightarrow IIP_{2,RX} \geq 3\text{dBm}$$

Note: The term "-3" is dependant upon the modulation index.

There are four operational modes of the MAX2392. The high-gain high-linearity (HGHL) and high-gain medium-linearity (HGML) modes are recommended for receiving a weak signal in the presence of a large blocker. Both modes result in measured  $IIP_{2,RX} \geq +15\text{dBm}$  for the reference-design receiver section, which meets the requirement by at least 12dB of margin.

## Phase Noise and Reciprocal Mixing

The 3GPP TD-SCDMA standard does not explicitly specify the phase noise of the VCO; instead it is derived from other specifications that depend on it. Transmitter EVM is one of the parameters that is impacted by the transmitter's VCO +PLL phase noise, as previously described, though it does not place a stringent phase-noise requirement on the radio. Receiver sensitivity is also dependent on LO phase noise, but it also does not place a stringent phase-noise requirement on the radio, even in the case of 16QAM modulation. Two specifications that tend to impose stringent specifications on LO phase noise are the blocking and two-tone intermodulation characteristics minimum requirements. These imposed specifications are manifested in a phenomenon referred to as reciprocal mixing, or the modulation of the LO sideband noise onto an interferer, as demonstrated in **Figure 5**.

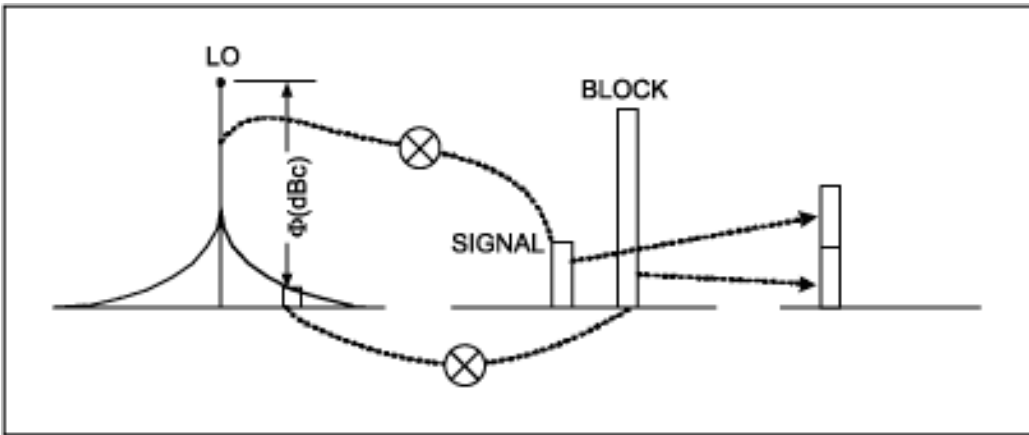

Figure 5. Reciprocal mixing of LO phase noise onto an interferer.

As mentioned in the discussion of blocking and two-tone intermodulation requirements, receiver sensitivity is allowed to degrade by 3dB in these test scenarios. We assume that all degradation is due to the phase-noise reciprocal mixing, and the receiver noise figure is less than 9dB as required by the standard. We can then deduce the required LO phase noise using the following equation:

$$P_{MIX}(dBm) = (P_{BLOCKER} + \Phi_N) \leq -174 + 9 \quad (\text{Eq. 4})$$

$$\Rightarrow \Phi(dBc/Hz) \leq -165 - P_{BLOCKER}(dBm)$$

The maximum interference power noted in the blocking and two-tone intermodulation test cases is a -46dBm tone at  $\pm 3.2$ MHz offset from the desired signal center frequency. Substituting this value into the above equation, we get a requirement for receiver LO phase noise to be less than -119dBc/Hz at 3.2MHz offset from the carrier. The measured phase noise of the MAX2392 VCO is -129dBc/Hz, which meets the requirement with 10dB of margin.

For out-of-band blocking, the SAW filter before the LNA knocks down all out-of-band interferences to an acceptable level to avoid LNA compression. The SAW filter between the LNA and mixer may not be needed because the blocker level at the LNA output is already low enough as compared with the mixer IP2 and IP3. An interstage filter provides the required balun function, so the additional filtering benefit is provided at no extra cost. For example, at  $\pm 85$ MHz offset, the specified blocker is -15dBm. If the SAW provides 30dB attenuation, the blocker level at LNA is -46dBm (1dB loss from T/R switch), which is similar to the in-band blocker level and can be analyzed by the above method in terms of IM2 and IM3. Measured results suggest that there is at least 3dB of margin from 3GPP requirements in each blocker test.

## Summary

Maxim's TD-SCDMA reference design V2.1 fully meets the 3GPP standard requirements with at least 3dB of margin for all key receiver specifications.

---

Application Note 3961: [www.maxim-ic.com/an3961](http://www.maxim-ic.com/an3961)

### More Information

For technical support: [www.maxim-ic.com/support](http://www.maxim-ic.com/support)

For samples: [www.maxim-ic.com/samples](http://www.maxim-ic.com/samples)

Other questions and comments: [www.maxim-ic.com/contact](http://www.maxim-ic.com/contact)

---

### Automatic Updates

Would you like to be automatically notified when new application notes are published in your areas of interest? [Sign up for EE-Mail™](#).

---

### Related Parts

MAX2392: [QuickView](#) -- [Full \(PDF\) Data Sheet](#) -- [Free Samples](#)

MAX2507: [QuickView](#)

AN3961, AN 3961, APP3961, Appnote3961, Appnote 3961

Copyright © by Maxim Integrated Products

Additional legal notices: [www.maxim-ic.com/legal](http://www.maxim-ic.com/legal)