

APPLICATION NOTE 3956

## Modifying the MAX2010 for Operation at 360MHz

*Abstract: This application note showcases simple changes to a standard EV kit for the MAX2010 (adjustable RF predistorter) to optimize its operational frequency to 360MHz. By default, this predistortion component is specified for 500MHz to 1100MHz operation. However, a few modifications to a standard MAX2010 EV kit can optimize its operation for lower frequency operation.*

### Overview of Modifications

Experimentation has shown that the frequency range of the [MAX2010](#) adjustable RF predistorter can be extended below 500MHz by implementing simple changes to the input and output matches of the phase section. Note that these changes pertain to the phase section only. Similar changes may be possible for the gain section as well, though Class AB applications are best served by employing only the phase expansion from the MAX2010.

Using the standard MAX2010 EV kit (**Figure 1**), modify the following components to yield optimal performance at 360MHz:

- C1: change from 100pF to 330pF
- C11: change from 2.2pF to 5.6pF
- L1, L2: change from 5.6nH to 19nH (Coilcraft 0402CS-19NXJB)
- C12: change from 2.2pF to 5.6pF
- C10: change from 100pF to 220pF

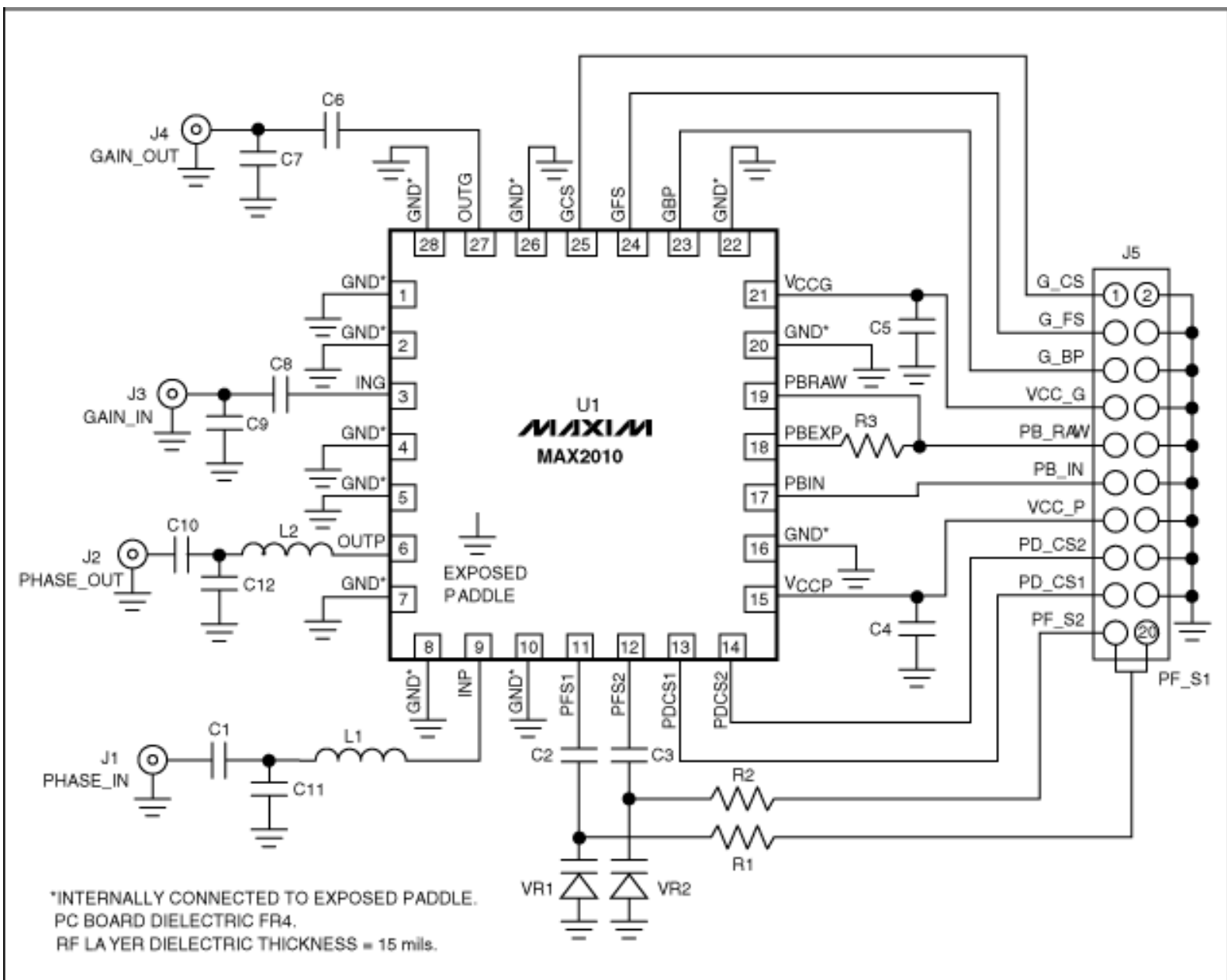

Figure 1. MAX2010 EV kit schematic.

# Resulting Phase-Expansion Characteristics at 360MHz

The plot in **Figure 2** depicts the typical phase expansion possible at 360MHz after employing the changes outlined in the previous section.

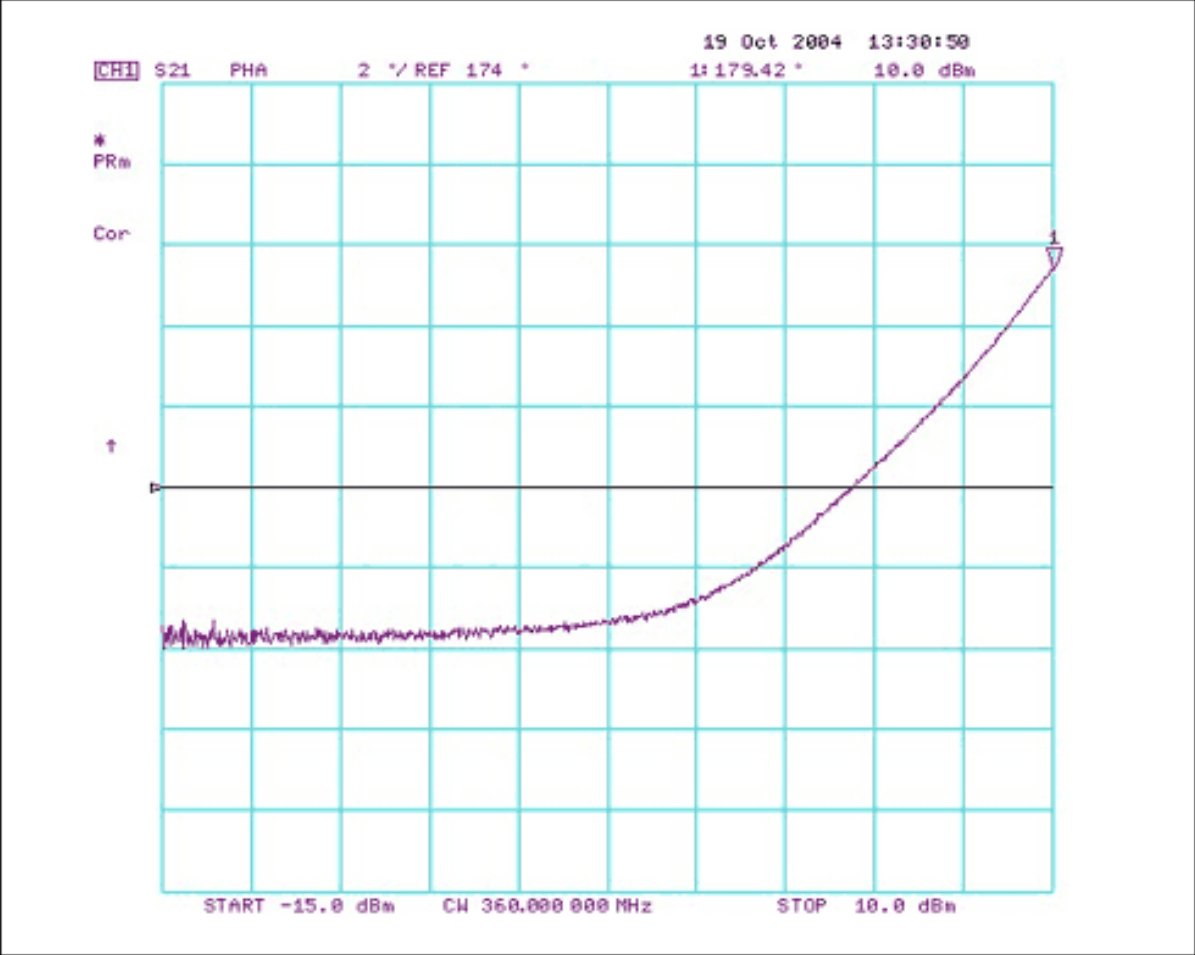

Figure 2. MAX2010 phase-expansion characteristics at 360MHz.

# Input-Matching Characteristics at 360MHz

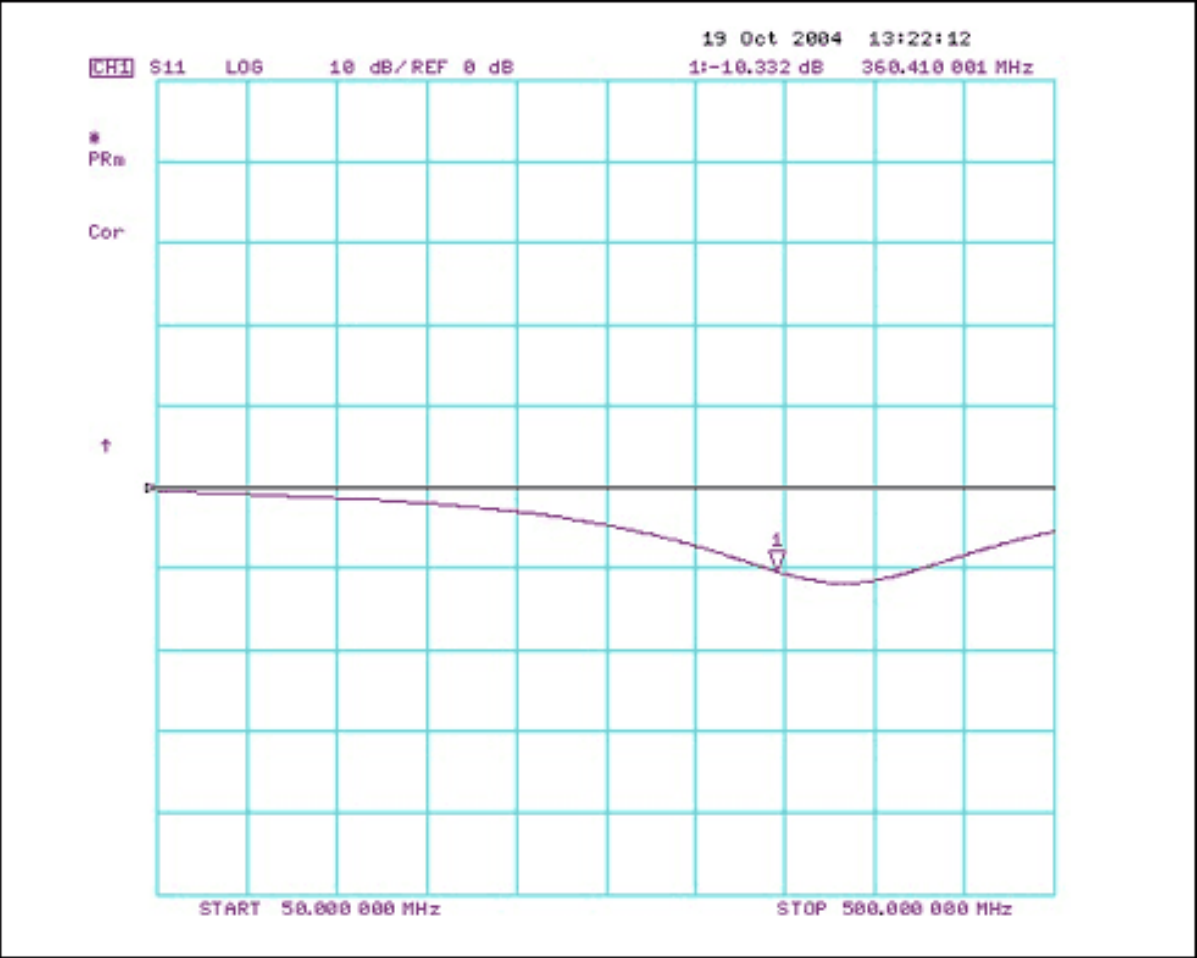
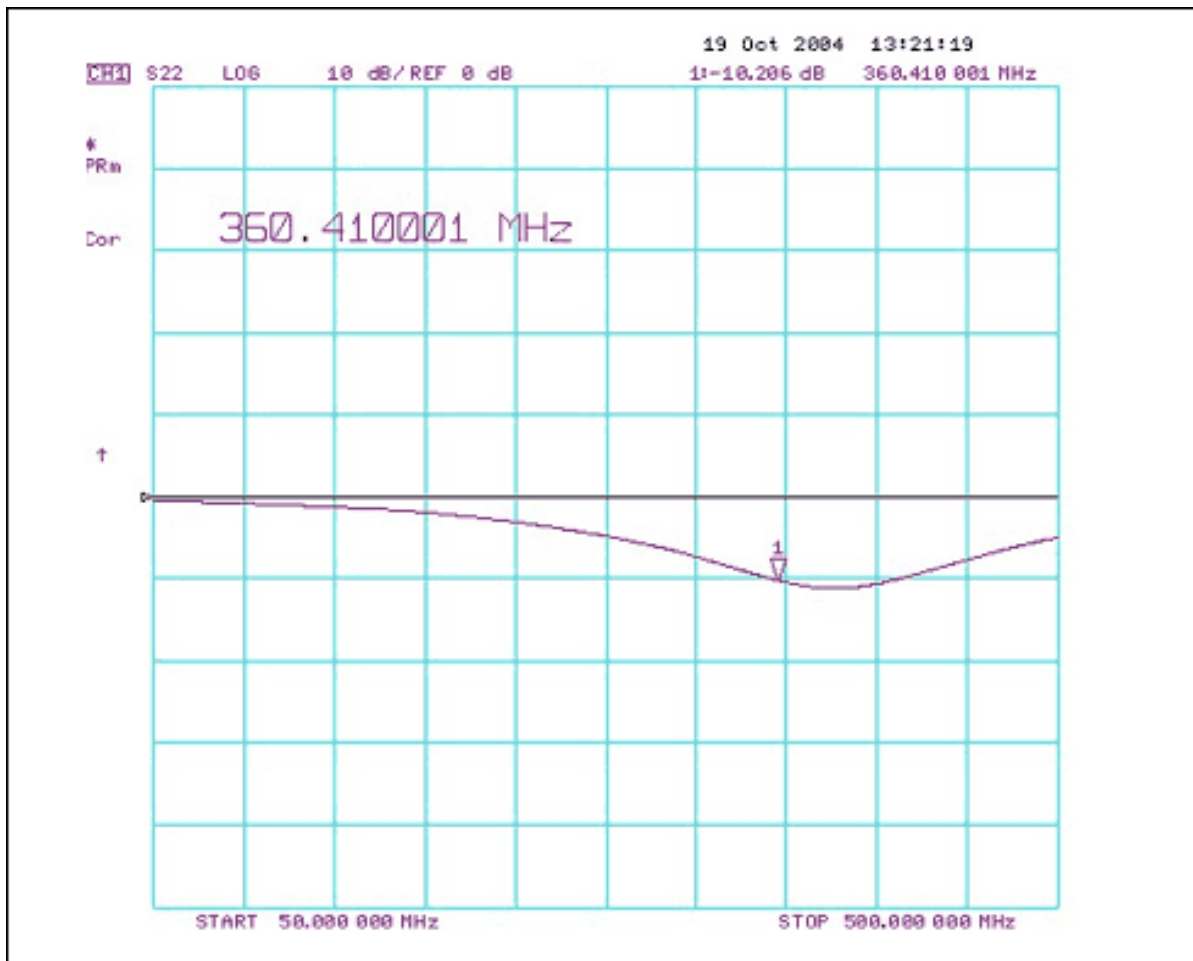

Figure 3. MAX2010 input match at 360MHz.

## Output-Matching Characteristics at 360MHz



**Figure 4.** MAX2010 output match at 360MHz.

Application Note 3956: [www.maxim-ic.com/an3956](http://www.maxim-ic.com/an3956)

### More Information

For technical support: [www.maxim-ic.com/support](http://www.maxim-ic.com/support)

For samples: [www.maxim-ic.com/samples](http://www.maxim-ic.com/samples)

Other questions and comments: [www.maxim-ic.com/contact](http://www.maxim-ic.com/contact)

### Automatic Updates

Would you like to be automatically notified when new application notes are published in your areas of interest? [Sign up for EE-Mail™](#).

### Related Parts

MAX2010: [QuickView](#) -- [Full \(PDF\) Data Sheet](#) -- [Free Samples](#)

AN3956, AN 3956, APP3956, Appnote3956, Appnote 3956

Copyright © by Maxim Integrated Products

Additional legal notices: [www.maxim-ic.com/legal](http://www.maxim-ic.com/legal)