

APPLICATION NOTE 3955

Modifying the MAX2010 for Operation at 450MHz

Abstract: This application note showcases simple changes to a standard EV kit for the MAX2010 (adjustable RF predistorter) to optimize its operational frequency to 450MHz. By default, this predistortion component is specified for 500MHz to 1100MHz operation. However, a few modifications to a standard MAX2010 EV kit can optimize its operation for lower frequency operation.

Overview of Modifications

Experimentation has shown that the frequency range of the [MAX2010](#) adjustable RF predistorter can be extended below 500MHz by implementing simple changes to the input and output matches of the phase section. Note that these changes pertain to the phase section only. Similar changes may also be possible for the gain section, though Class AB applications are best served by employing only the phase expansion from the MAX2010.

Using the standard MAX2010 EV kit (**Figure 1**), modify the following components to yield optimal performance at 450MHz:

- C11: change from "not installed" to 4.7pF
- C1: change from 8.2pF to 330pF
- L1: change from 5.6nF to 15nH
- C12: change from "not installed" to 4.7pF
- L2: change from 5.6nF to 15nH

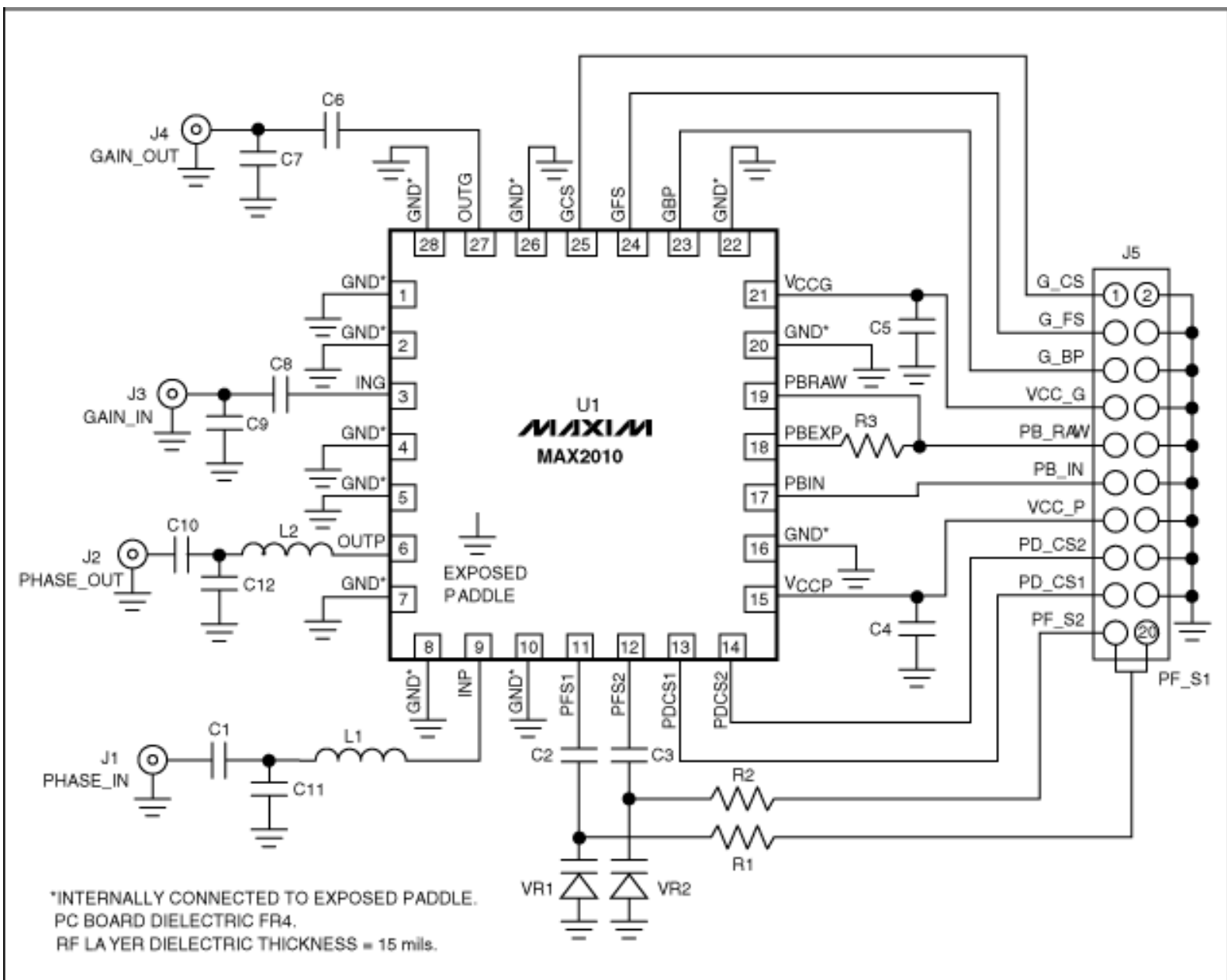

Figure 1. MAX2010 EV kit schematic.

Resulting Phase-Expansion Characteristics at 450MHz

The plot in **Figure 2** depicts the typical phase expansion possible at 450MHz after employing the changes outlined in the previous section.

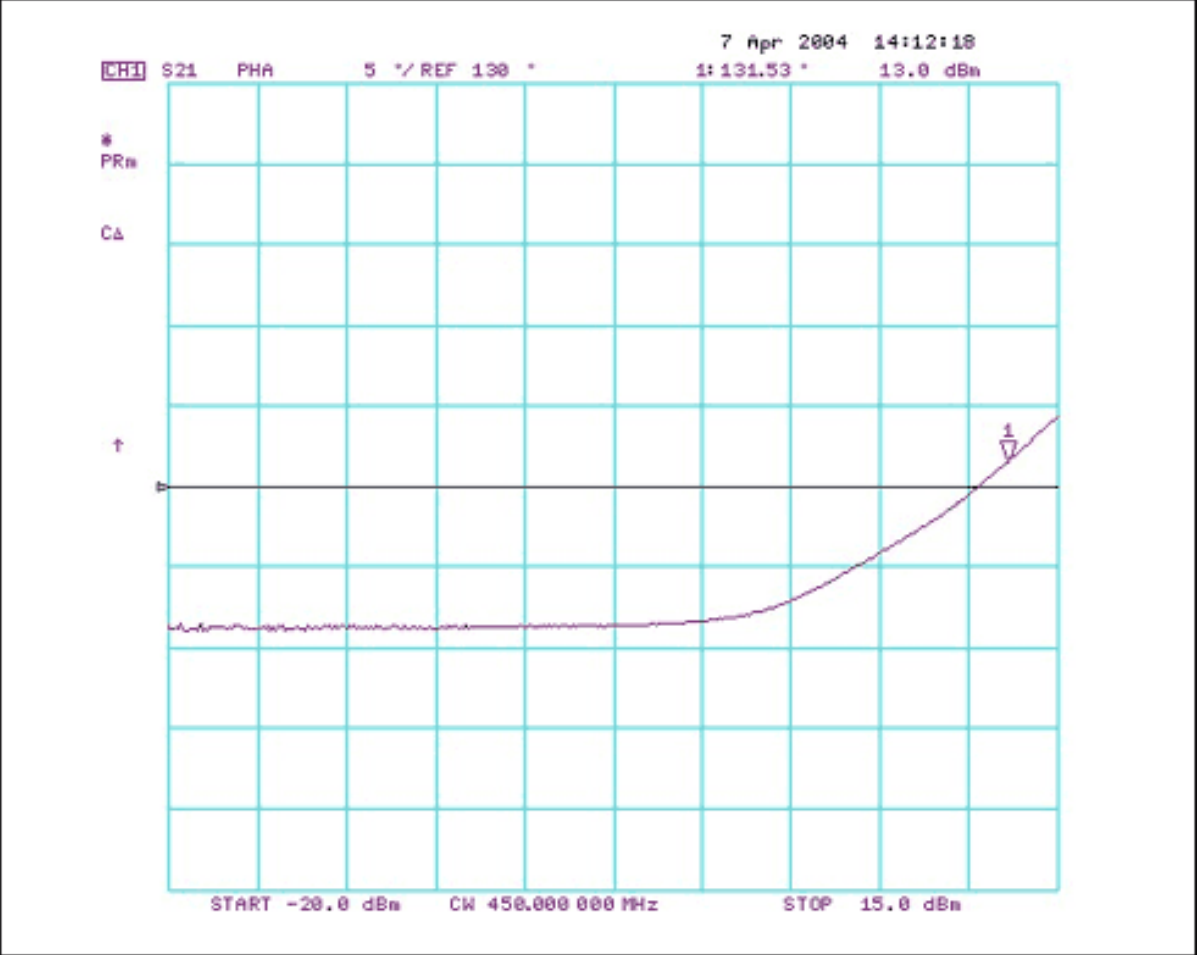

Figure 2. MAX2010 phase expansion characteristics at 450MHz.

Parasitic Gain-Compression Characteristics at 450MHz

The graph in **Figure 3** displays the typical gain-compression characteristic that can be achieved after changing the aforementioned components to their new values.

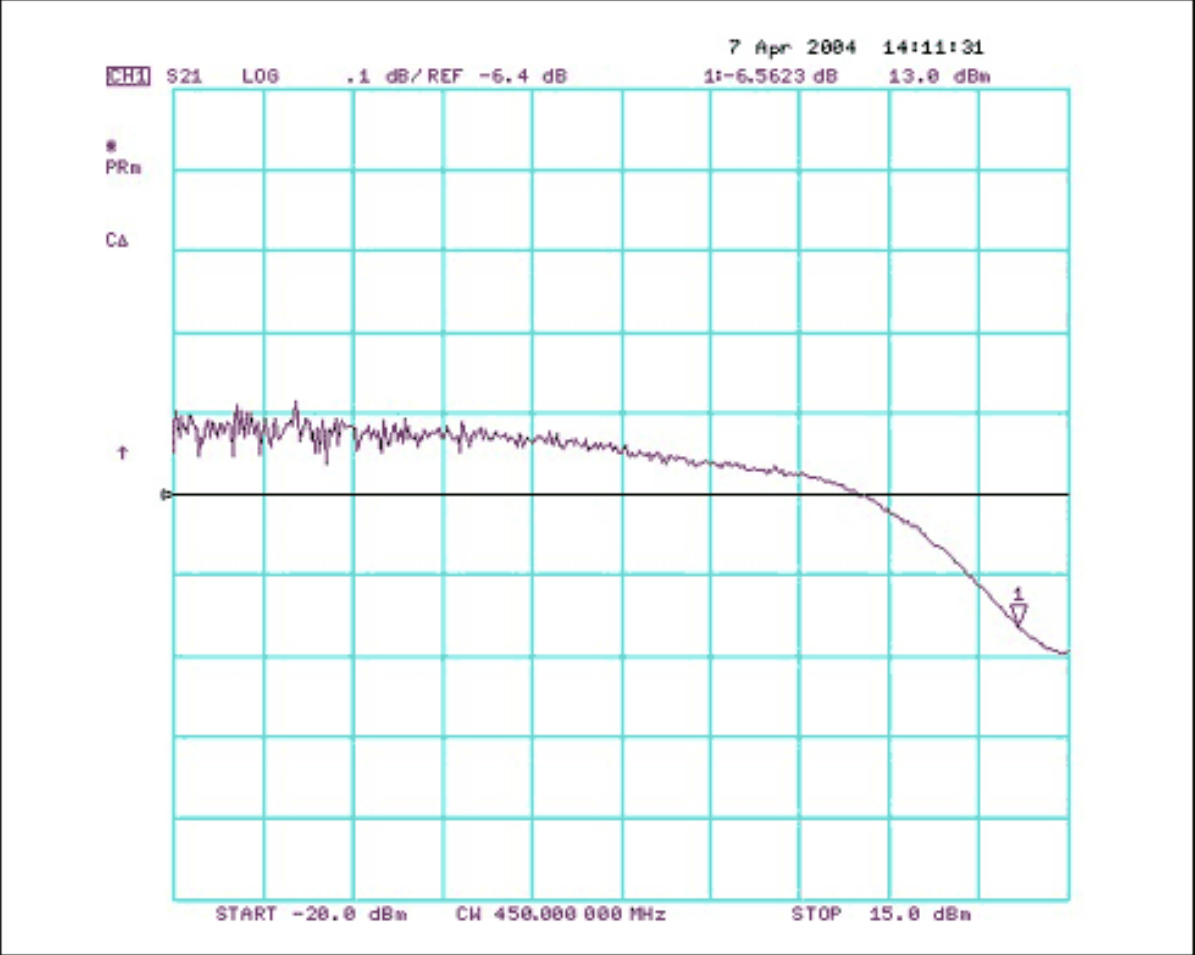

Figure 3. MAX2010 parasitic gain-compression characteristics at 450MHz.

Input-Matching Characteristics at 450MHz

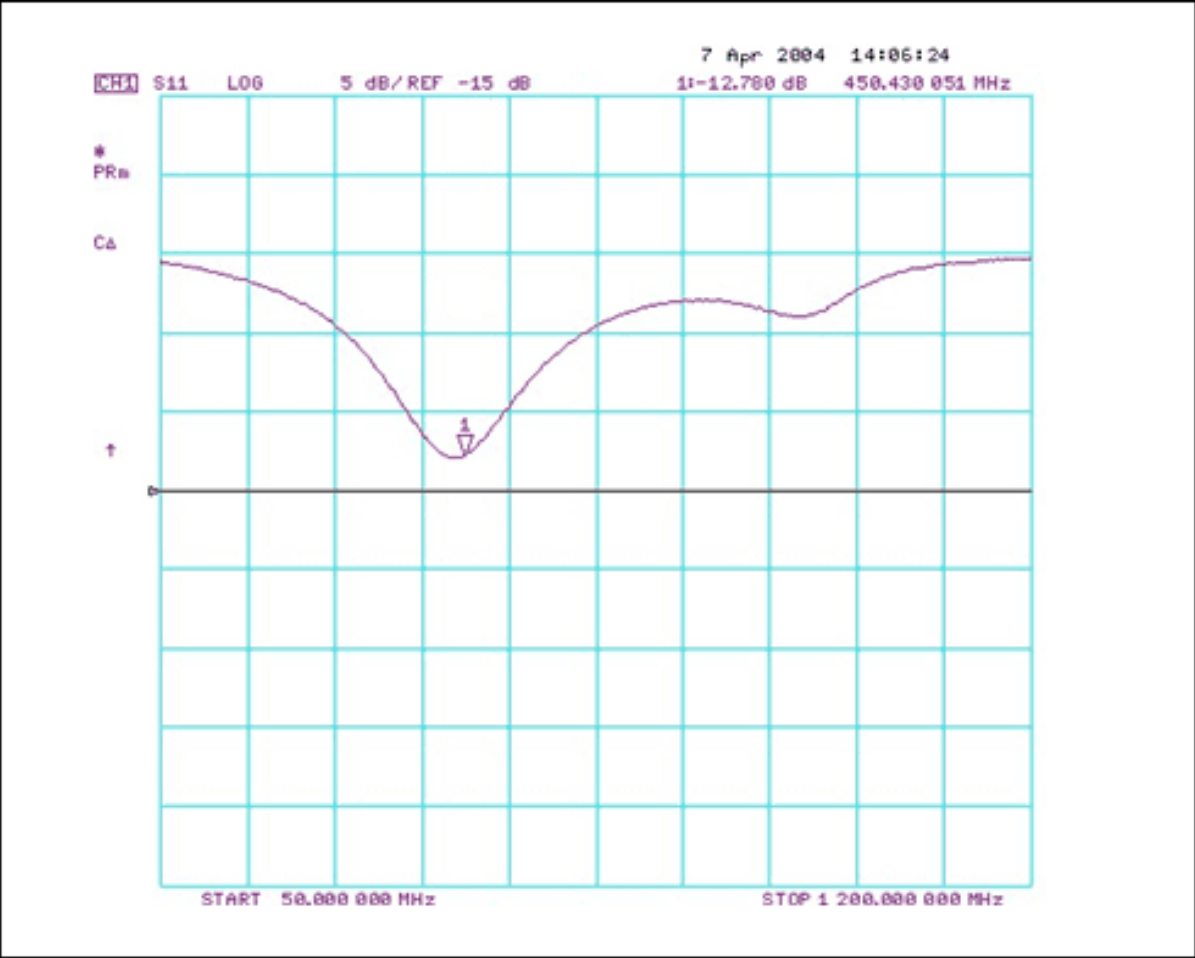

Figure 4. MAX2010 input match at 450MHz.

Output-Matching Characteristics at 450MHz

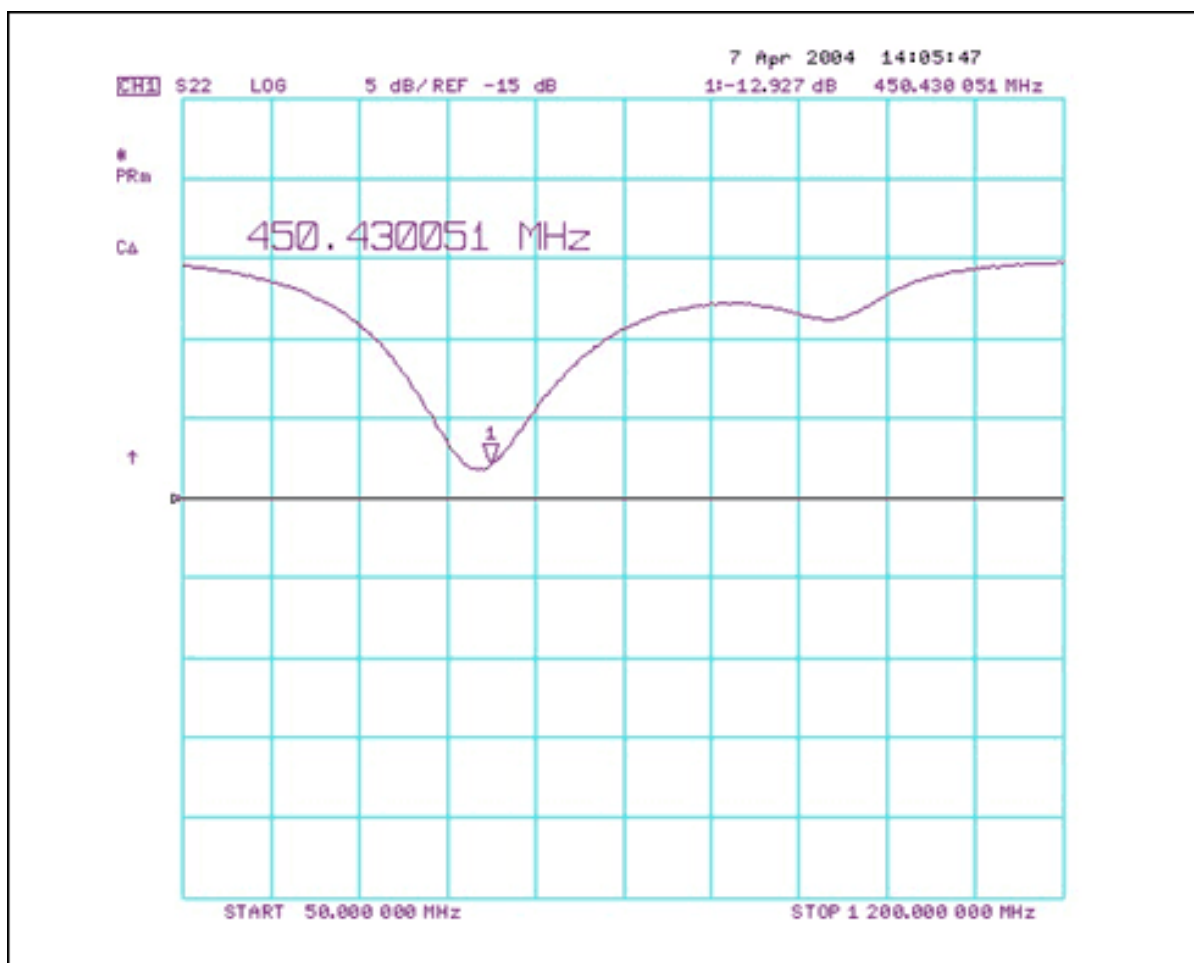

Figure 5. MAX2010 output match at 450MHz.

Application Note 3955: www.maxim-ic.com/an3955

More Information

For technical support: www.maxim-ic.com/support

For samples: www.maxim-ic.com/samples

Other questions and comments: www.maxim-ic.com/contact

Automatic Updates

Would you like to be automatically notified when new application notes are published in your areas of interest? [Sign up for EE-Mail™](#).

Related Parts

MAX2010: [QuickView](#) -- [Full \(PDF\) Data Sheet](#) -- [Free Samples](#)

AN3955, AN 3955, APP3955, Appnote3955, Appnote 3955

Copyright © by Maxim Integrated Products

Additional legal notices: www.maxim-ic.com/legal