



APPLICATION NOTE 3929

## Avalanche-Photodiode Detector Circuit Limits Current to 1mA and Improves Transient Response

*Abstract: New high-speed avalanche-photodiode (APD) detectors require new support circuits with lower current limits. This application note uses the MAX1932, a digitally controlled APD bias supply IC, to design an improved bias circuit for these new APD detectors. This circuit features enhancements to the standard MAX1932 application circuit.*

### Designing a Low-Current Bias Circuit for APD Detectors

**Figure 1** illustrates how to use the [MAX1932](#) to design a low-current bias supply IC for high-speed APD detectors. This circuit uses a capacitor (CA) and resistor (RA) to inject leading phase shift into the feedback loop, which provides improved transient response over the standard MAX1932 application circuit. Leading phase shift also helps to offset the phase lag generated from the output filter formed with R1 and C3. The DA diode and RB resistor improve recovery from a current-limit fault by allowing the duty cycle to soft-start after the fault goes away. A bleeder resistor (RA) is placed in front of the current-sense resistor R1 to improve current-sense accuracy.

This circuit shows external voltage control ( $V_{\text{CONTROL}}$ ). For internal control using the MAX1932's internal DAC and SPI™ serial-control interface, connect R6 to DACOUT (U1 Pin-6).

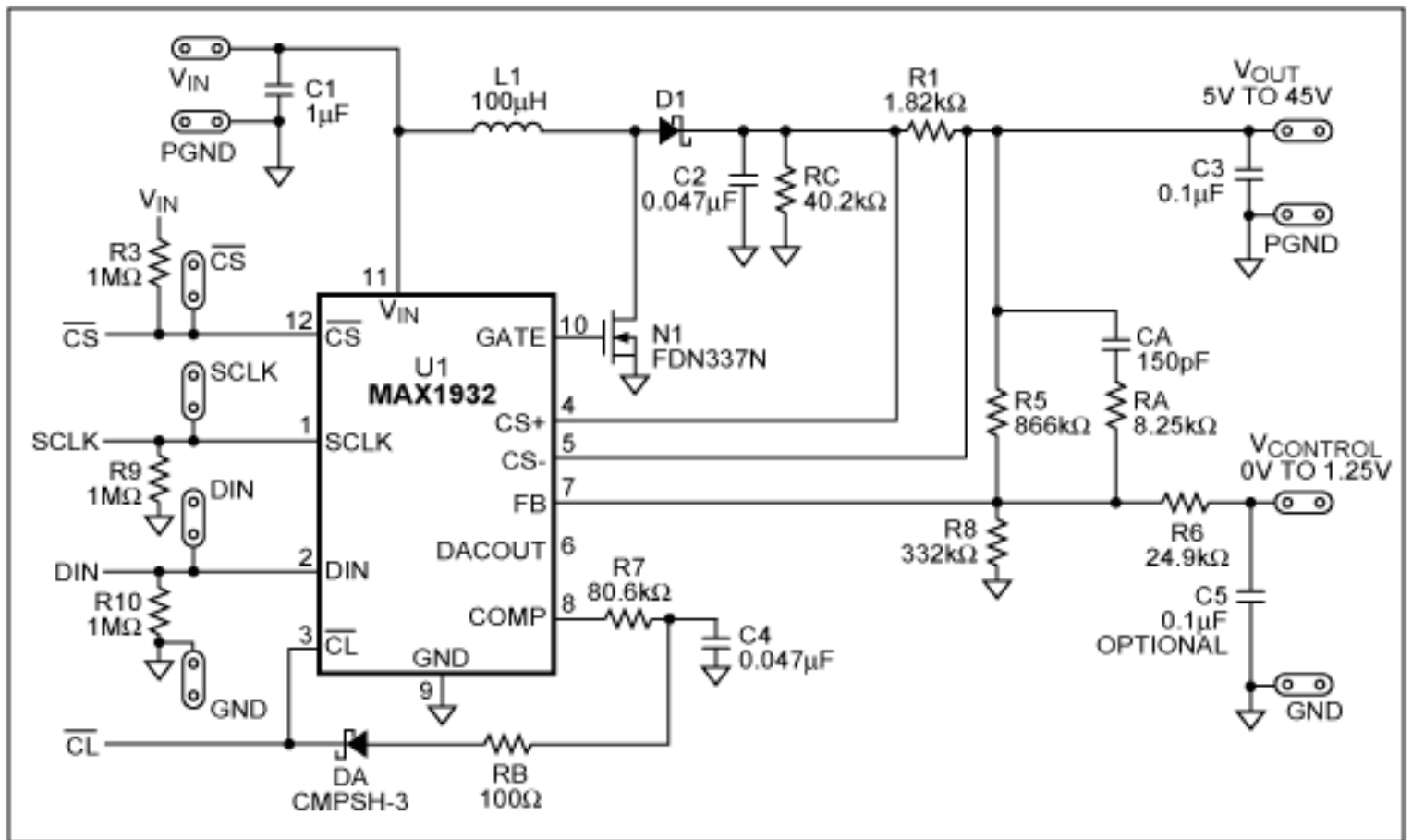

Figure 1. The enhanced MAX1932 bias circuit offers improved current limit and transient response. Adding DA and RB improves recovery from current limit, while adding CA and RA improves transient response.

**Table 1. The bill of materials for the MAX1932 circuit illustrated in this application note. (3V to 5V input, 5V to 45V output)**

DESIGNATION	QTY	DESCRIPTION
C1	1	1.0 $\mu$ F, 6.3V X5R ceramic cap. (0603) TDK (C2012X7R2A473K)
CA	1	150pF 100V COG ceramic cap. (0805) Panasonic (ECJ-2VC2A151J)
C2	1	0.047 $\mu$ F, 100V X7R ceramic cap. (0805) TDK (C2012XR2A473K)
C3	1	0.1 $\mu$ F, 100V X7R ceramic cap. (1206) TDK (C3216X7R2A104K)
C5 (optional)	1	0.1 $\mu$ F, 16V X7R ceramic cap. (0603) Taiyo Yuden (C1608X7R1C104K)
C4	1	0.47 $\mu$ F, 16V X7R (0603) Panasonic (ECJ-1VB1E473K)
D1	1	150mA, 100V Schottky diode (SOD123) Diodes Inc. BAT56W
DA	1	30V Schottky diode Central Semi CMPSH-3
N1	1	30V, 0.065 $\Omega$ n-channel (SOT-23) Fairchild (FDN337N)
RB	1	100 $\Omega$ , 1% resistor (0402)
R1	1	1.82k $\Omega$ , 1% resistor (0605)
RA	1	8.25k $\Omega$ , 1% resistor (0402)
R6	1	24.9k $\Omega$ , 1% resistor (0402)
R7	1	80.6k $\Omega$ , 5% resistor (0402)
RC	1	40.2k $\Omega$ , 1% resistor (0805)
R8	1	332k $\Omega$ , 1% resistor (0402)
R5	1	866k $\Omega$ , 1% resistor (0805)
R3, R9, R10	3	1.0M $\Omega$ , 5% resistor (0402)
L1	1	100 $\mu$ H, 170mA inductor Sumida (CMD4D13-101MC)
U1	1	<b>Digitally controlled, 0.5% accurate, safest APD bias supply Maxim MAX1932ETC (12-Pin Thin QFN)</b>

SPI is a trademark of Motorola, Inc.

---

Application Note 3929: [www.maxim-ic.com/an3929](http://www.maxim-ic.com/an3929)

### More Information

For technical support: [www.maxim-ic.com/support](http://www.maxim-ic.com/support)

For samples: [www.maxim-ic.com/samples](http://www.maxim-ic.com/samples)

Other questions and comments: [www.maxim-ic.com/contact](http://www.maxim-ic.com/contact)

---

### Automatic Updates

Would you like to be automatically notified when new application notes are published in your areas of interest?

[Sign up for EE-Mail™.](#)

---

### Related Parts

MAX1932: [QuickView](#) -- [Full \(PDF\) Data Sheet](#) -- [Free Samples](#)

AN3929, AN 3929, APP3929, Appnote3929, Appnote 3929

Copyright © by Maxim Integrated Products

Additional legal notices: [www.maxim-ic.com/legal](http://www.maxim-ic.com/legal)