

Design Note:

HFDN - 43.0

Rev.1; 04/08

**GENERATING A TX POWER MONITOR IN BURST MODE APPLICATIONS
(USING MAX3643 AND THE DS1863 OR DS1865)**



Maxim Integrated Products



Generating a TX Power Monitor in Burst Mode Applications

1 Introduction

The ability to monitor optical output power is often a desirable feature in optical module applications. The monitors provide the module user an approximation of the average optical transmitter power which can then be used as a diagnostic tool in ensuring the proper operation of the module. Transmit power monitors are commonly used in SFF and SFP modules and methods for their calibration and accuracy have been specified in documents such as SFF-8472. The monitoring methods in conventional continuous-mode applications are straightforward and common, as they are based on a simple measurement of a monitor diode current. Monitoring of a bursting transmitter signal however, can be difficult.

Passive optical networks (PON) use burst type optical transmitters that transmit data (have optical output power) for a very short period of time. These transmitters are only active (bursting data) a small percentage of the time and the burst time will vary from one burst to another. These factors lead to difficulties in implementing a low-cost burst TX power monitor. This application note illustrates a simple and low-cost method for generating a burst TX power monitor using the MAX3643 laser driver and the DS1863 or DS1865 controllers. Test data is also provided illustrating the operation and performance of the monitor circuit.

2 Background Information

In continuous mode optical transmitter applications the power monitor value is derived from the current in a back facet photodiode that is mounted to the laser. This photodiode is often called a “monitor diode”. The photodiode outputs a current that is approximately proportional to the transmitter optical output power. There will be some tracking error associated with this monitor caused by temperature induced changes in coupling efficiency and responsivity but it is in general a good and low-cost solution to measure the optical output power of the laser.

The bandwidth of the monitor diode is generally much less than the modulation bandwidth of the laser; however, the monitor will track some of data induced variations in the optical output power (Figure 1). In a continuous mode application, the monitor current is often heavily filtered (analog or digital) to obtain the average value that corresponds to the average optical transmitted power (Figure 1).

In burst mode applications the transmitter is only on for a relatively short period of time. The length of each burst will also vary from one burst to another. For these reasons, a heavily filtered monitor diode current output will not provide a good representation of the TX power (Figure 2). Some filtering of the monitor diode current is still needed in burst applications. The amount of filtering is often based on the smallest burst length that would be expected knowing that the monitor current should reach its final value before the end of the burst. To get an accurate representation of the average optical transmit power during a burst of data the monitor diode current must then be sampled during the burst after the monitor diode current has reached its final value (Figure 2).

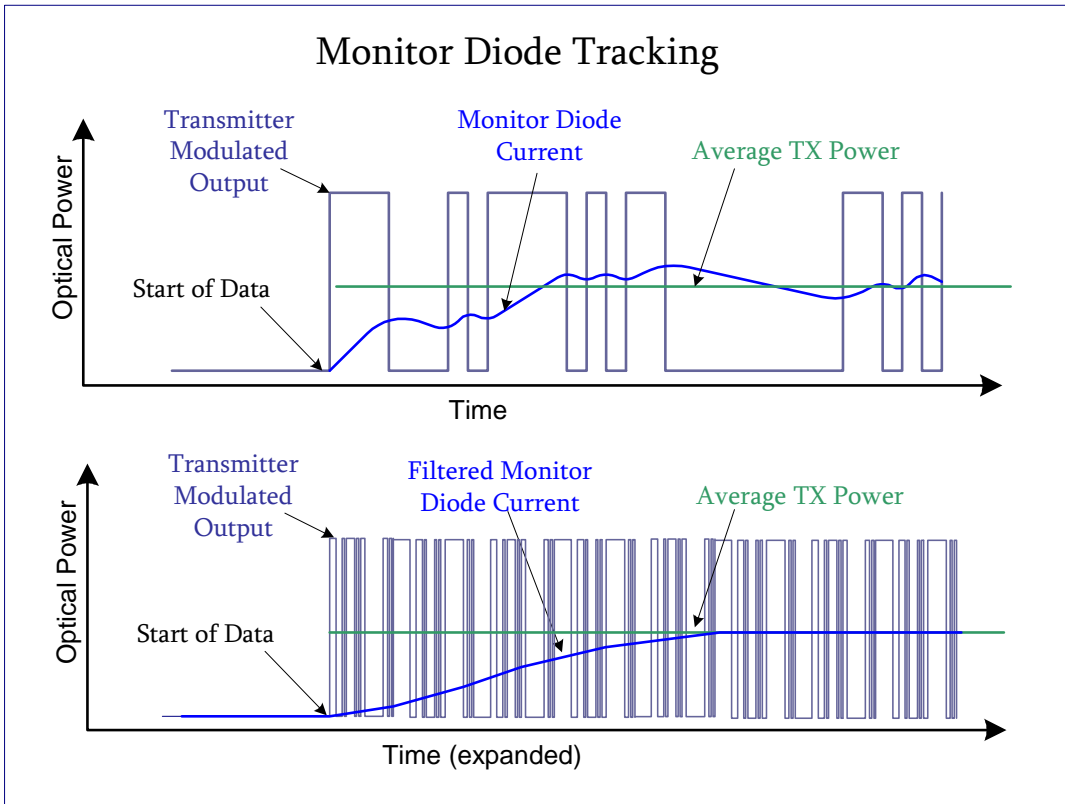

Figure 1. Monitor Diode Tracking

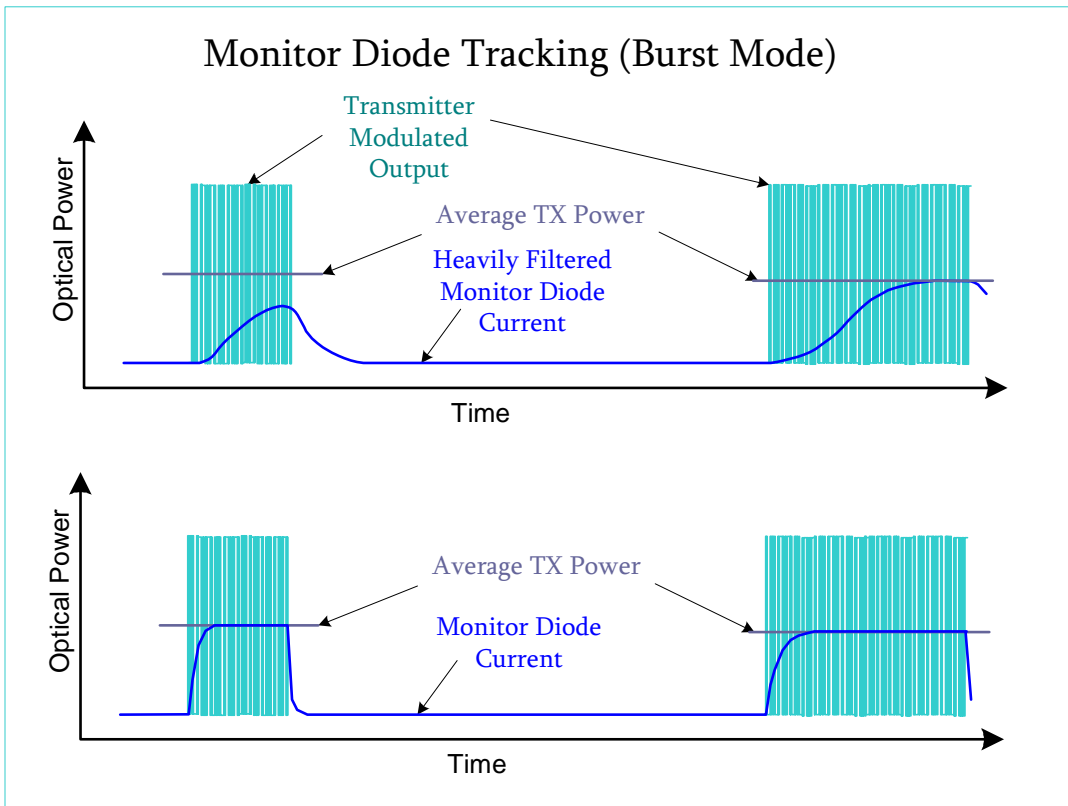

Figure 2. Monitor Diode Tracking (Burst Mode)

3 Configuration Diagrams

A typical configuration of the MAX3643 with the DS1863/65 is shown in Figure 3. In this configuration the DS1863 monitors the power of each burst through the photodiode and adjusts the bias current as needed to provide a constant optical output power. The DS1863/65 also compares the monitor current to configurable alarm and warning levels. This allows the user to set safety limits on the burst transmitter optical power and generate flags or interrupts based on the level of photodiode current. Each burst over approximately 400ns will be monitored and checked for high or low levels in this configuration. However, an average transmit power monitor is not available in the DS1863 device.

To generate an average power monitor in a burst-mode application the configuration shown in Figure 4 can be used. The MAX3643 provides a sample and hold feature that can be used to sample the ground referenced voltage created by the monitor diode current connected to a resistor. This sample and hold feature is often needed when using low-cost microcontrollers with the MAX3643. The DS1863 however does not need to use this feature as it has adequate capabilities to monitor the voltage at the node directly. This sample and hold feature in the

MAX3643 can therefore be used to provide an average TX power monitor. An illustration of how this monitor is generated by these components is shown in Figure 4.

The monitor diode inputs of both the MAX3643 and the DS1863/65 are high impedance. A resistor (R1, see Figure 4) is placed between the MAX3643 MD input and the laser photodiode to help isolate capacitance of the node. A resistance value between 1k and 10k is recommended. The sampled output is then sent to the MDOUT pin at the conclusion of each burst (Figure 5).

Between bursts the MDOUT pin of the MAX3643 returns to a reference voltage value of approximately 1.2V. The switch (MAX4706 or MAX4729) is then used to sample the MDOUT voltage. The MAX3643 BENOUT signal is used to gate the switch sample which removes the 1.2V reference voltage. A capacitor (C1) on the output of the switch is used to hold the voltage that is proportional to the monitor diode current. The DS1863 can then be used to convert the analog voltage into an internally calibrated digital value that is an average value of each burst's transmitted power. Warning and Alarm levels can also be set for this voltage inside the DS1863/65.

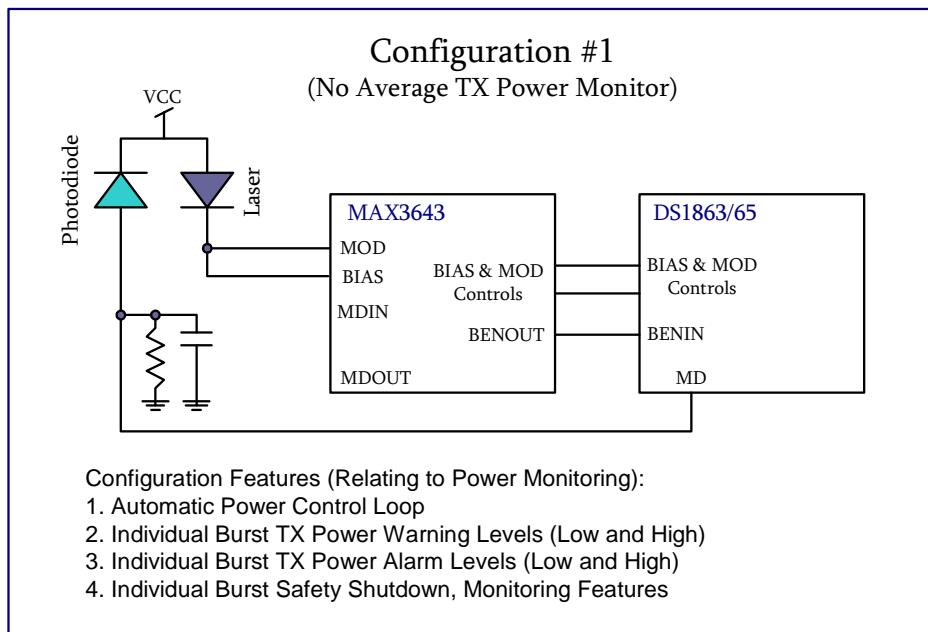

Figure 3. Configuration #1, No Average TX Power Monitor

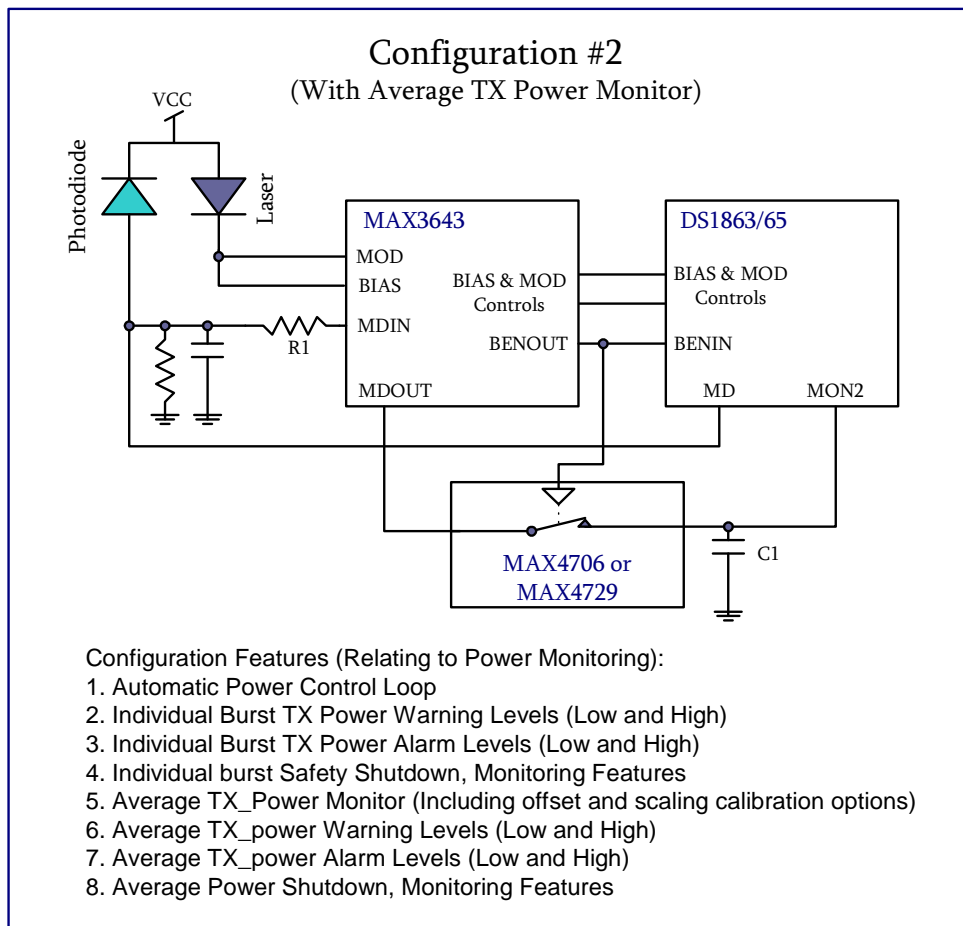

Figure 4. Configuration #2, Average TX Power Monitor

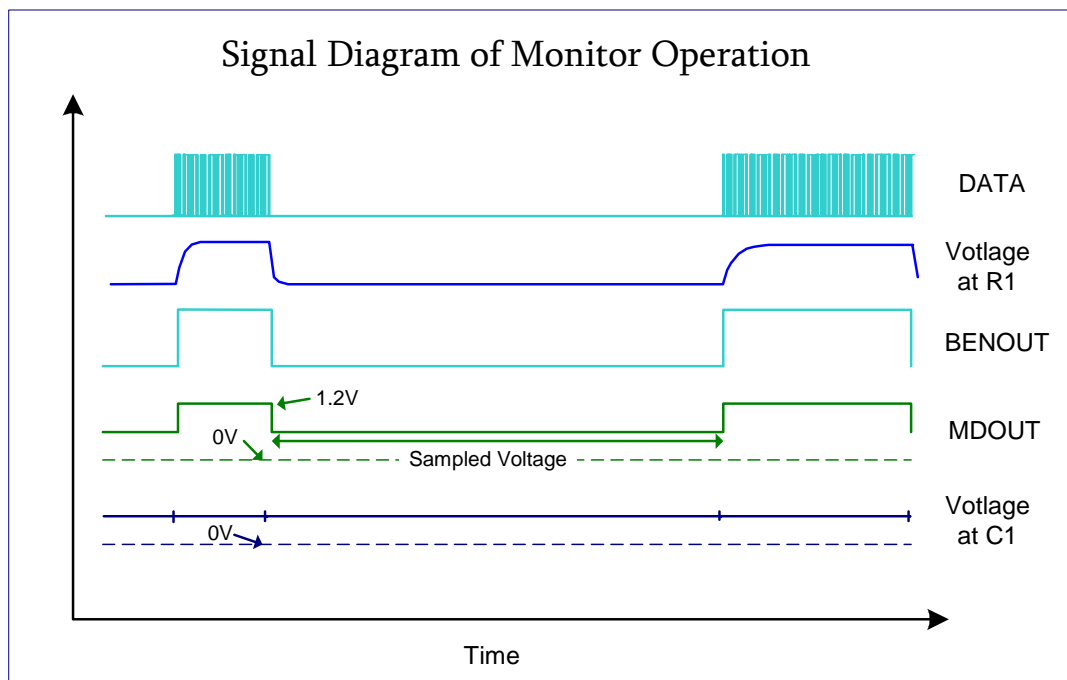

Figure 5. Monitor Diode Tracking (Burst Mode)

4 Test Data

Using configuration #2 shown above in Figure 4 and an ExceLight Triplexer (Model # SXT5241-Q/GPI) the following test data was obtained.

Figure 6 shows the linear relationship between the average transmitted output power and the monitor.

Figure 7 shows the monitor output voltage as the burst duty cycle is changed. Note that when the duty cycle is high (approaching continuous mode

operation) the accuracy of the monitor will reduce. At 100% duty cycle the monitor output will not function / update. As seen in Figure 7, the monitor is very stable to about 90% duty cycle. Given that most burst applications run an average duty cycle of much less than 50%, the monitor will provide an accurate and stable measurement of the average transmitter power. When this signal is combined with the DS1863/65, an SFF 8472 compatible internally-calibrated monitor is provided.

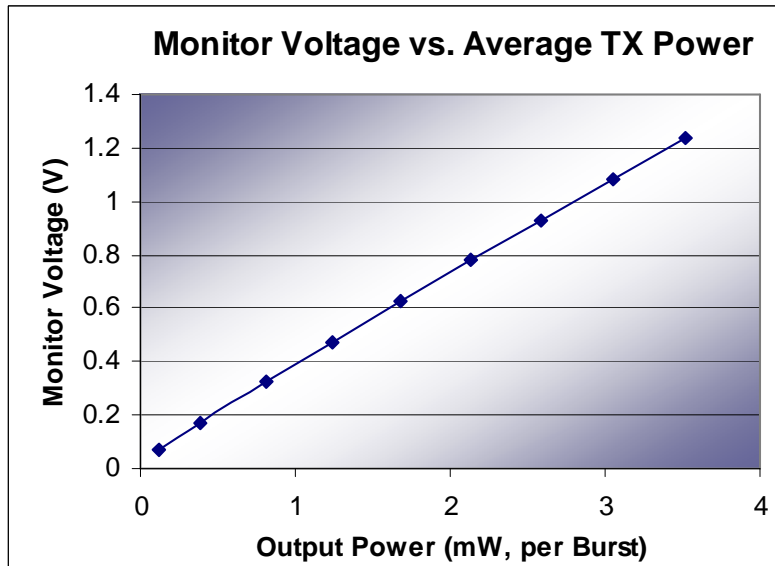

Figure 6. Monitor Voltage vs. Average TX Power

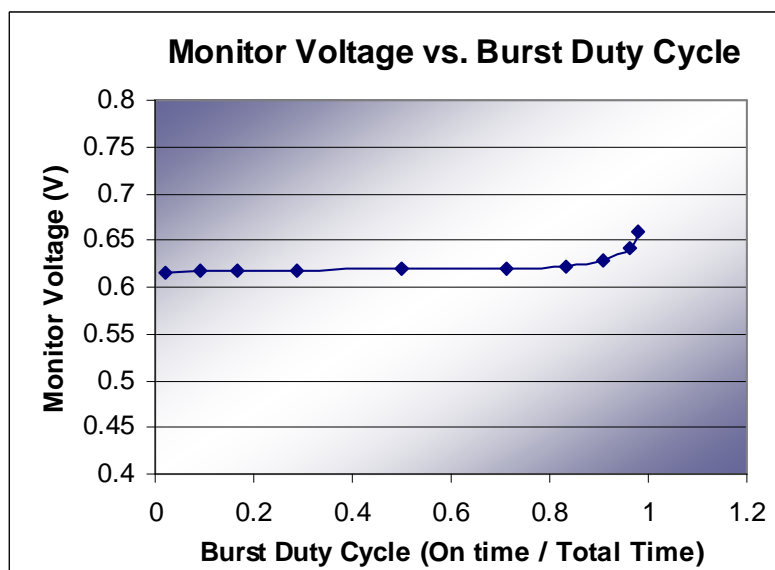

Figure 7. Monitor Voltage vs. Burst Duty Cycle