

APPLICATION NOTE 3909

# MAX2470/MAX2471 Couple MIMO Transceiver Reference Clocks

*Abstract: The MAX2470/MAX2471 are flexible, low-cost, high reverse-isolation buffer amplifiers for applications with discrete and module-based VCO designs. This application note shows the basic operation and techniques for coupling reference clocks in a MIMO transceiver.*

## Basic Operation of the MAX2470/MAX2471

Ideal for discrete and module-based VCO designs, the [MAX2470/MAX2471](#) are flexible, low-cost, high reverse-isolation buffer amplifiers. Both feature differential 50Ω outputs for driving a single differential (balanced) load or two separate single-ended (unbalanced) 50Ω loads. The MAX2470 offers a single-ended input and has two selectable frequency ranges of operation: 10MHz to 500MHz and 10MHz to 200MHz. The MAX2471 offers a differential input and operates from 10MHz to 500MHz. The MAX2470 operates from a single +2.7V to +5.5V supply. At -5dBm output power, it consumes 5.5mA in the high-frequency range and only 3.6mA in the low-frequency range. The MAX2471 operates from a +2.7V to +5.5V single supply and consumes 5.5mA.

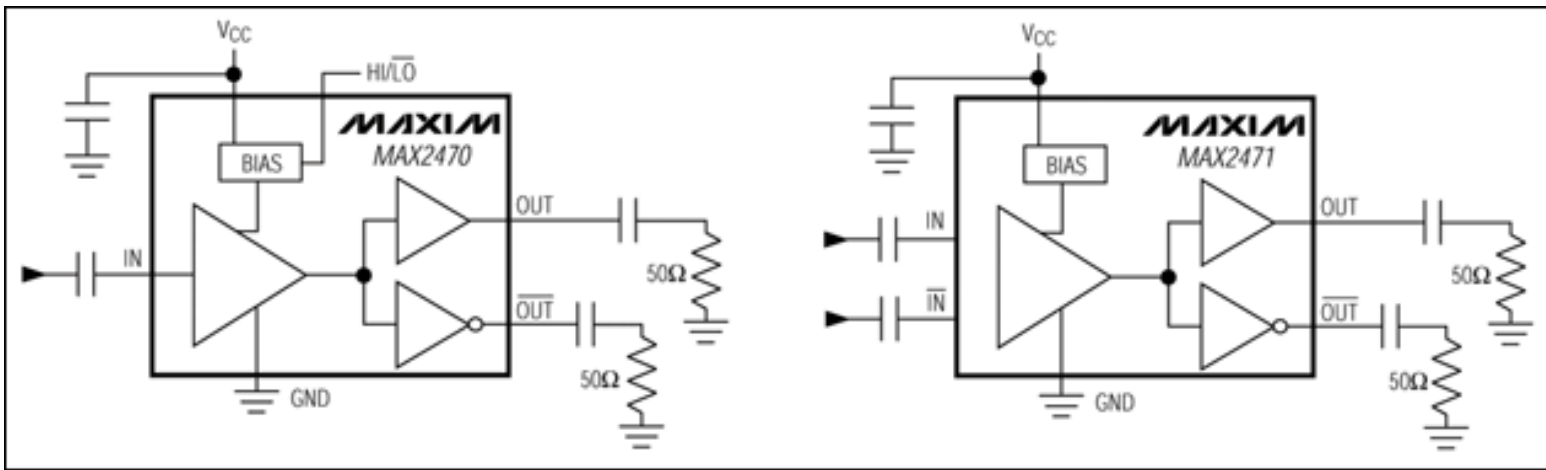

Figure 1. MAX2470 and MAX2471 block diagrams.

## Input Considerations

The MAX2470/MAX2471 (**Figure 1**) have high-impedance inputs, ideal for low-distortion buffering of a VCO. For applications with discrete transistor-based oscillator designs, simply AC-couple the oscillator directly to the inputs. The buffer's high input impedance results in minimal loading on the oscillator. For still higher input impedance and reduced loading effects, match the inputs with a shunt-L matching circuit followed by a series-blocking capacitor. For use with 50Ω VCO modules, terminate the buffer input(s) with a 50Ω shunt resistor followed by a series-blocking capacitor. This provides a very stable 50Ω termination and increases reverse isolation. For those applications needing both high gain and good input match, reactively match the buffer inputs to 50Ω with simple two-element matching circuits followed by a series-blocking capacitor.

## Output Considerations

The MAX2470/MAX2471 incorporate fully differential output stages capable of driving an AC-coupled 100Ω differential load or two AC-coupled 50Ω single-ended loads. This is ideal for applications that require the oscillator to drive two application circuits (e.g., a mixer and a PLL) simultaneously. The high output-to-output isolation ensures minimal interaction between multiple load circuits.

## Layout and Power-Supply Bypassing

A properly designed PCB is essential to any effective RF/microwave circuit. Be sure to use controlled impedance lines on all high-frequency inputs and outputs. Bypass the power supply with decoupling capacitors as close to the  $V_{CC}$  pins as possible. For long  $V_{CC}$  (inductive) lines, it may be necessary to insert additional decoupling capacitors further away from the device package.

Proper grounding of GND is essential. If the PCB uses a topside RF ground, connect GND directly to it. For a board where the ground plane is not on the component side, the best technique is to connect GND to the board with a plated through-hole (a via) to the ground plane close to the package.

## MIMO Applications

In MIMO applications, multiple RF transceivers need a common reference source, so the reference-signal output must be divided into enough paths to feed the common reference signal to each transceiver. Provided each transceiver has a single-ended reference input (i.e., unbalanced), one output port of the MAX2470 should be terminated with a  $50\Omega$  load resistor. The other output port should be divided into separate paths, one for each transceiver. One can not use the both output ports for MIMO applications because the two output ports have  $180^\circ$  of phase difference. With a  $50\Omega$  load, the MAX2470 output power should be set at  $-5\text{dBm}$  or lower. The designer should verify that the divided reference signal power meets the minimum reference signal level of the each transceiver chip.

## Conclusion

The MAX2470/MAX2471 VCO buffer amplifiers are ideal for coupling MIMO transceiver reference clocks when all considerations are met. For more detailed information on these parts please refer to the [data sheet](#). For what components could be best used with these devices or an evaluation schematic, please refer to the [evaluation kit](#).

---

Application Note 3909: [www.maxim-ic.com/an3909](http://www.maxim-ic.com/an3909)

### More Information

For technical support: [www.maxim-ic.com/support](http://www.maxim-ic.com/support)

For samples: [www.maxim-ic.com/samples](http://www.maxim-ic.com/samples)

Other questions and comments: [www.maxim-ic.com/contact](http://www.maxim-ic.com/contact)

---

### Automatic Updates

Would you like to be automatically notified when new application notes are published in your areas of interest? [Sign up for EE-Mail™](#).

---

### Related Parts

MAX2470: [QuickView](#) -- [Full \(PDF\) Data Sheet](#) -- [Free Samples](#)

AN3909, AN 3909, APP3909, Appnote3909, Appnote 3909

Copyright © by Maxim Integrated Products

Additional legal notices: [www.maxim-ic.com/legal](http://www.maxim-ic.com/legal)