

APPLICATION NOTE 3906

Creating a Bidirectional Current-Sense Amplifier from Two Unidirectional Current-Sense Amplifiers

Abstract: In many battery-current monitoring applications, bidirectional current sensing is required to measure both charge and discharge currents in the battery. This application note describes how to connect two unidirectional current-output, current-sense amps, such as the MAX4172 and MAX4173, to form one bidirectional current-sense amplifier.

Introduction

Many current-sense applications require bidirectional current-sensing capabilities. For instance, when a laptop is plugged into an AC power line, the AC adapter supplies power to the laptop and charges the battery. The battery's charge current is monitored to ensure that the battery does not overheat and that the total input power drawn from the AC adapter does not exceed UL-mandated limits. Similarly, the battery discharge current is monitored for fuel-gauging/active power management on the load device when the AC adapter is not available and battery capacity needs to be conserved. **Figure 1** shows a typical current-sense amplifier implementation in a battery-charging/-discharging application.

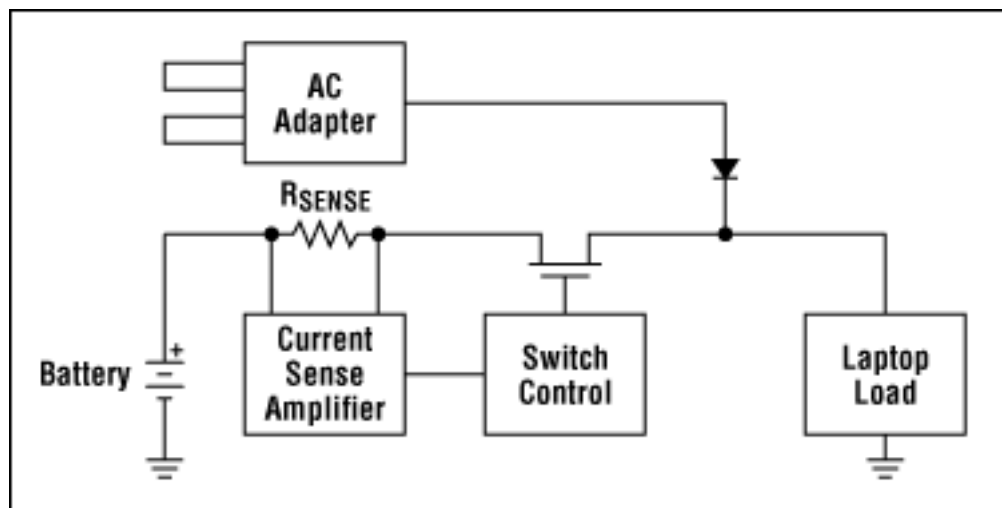

Figure 1. The typical battery-charging/-discharging circuit used in laptop applications.

Building a Bidirectional Current-Sense Amplifier

The [MAX4172](#), [MAX4173](#), and [MAX4073](#) are three popular unidirectional current-sense amplifiers that feature current outputs. The MAX4172 is available in a μ MAX[®] package and offers precision 1.6mV maximum offset voltage (0.75mV V_{OS} for SOIC version) and $\pm 2\%$ maximum gain-error specifications over the industrial temperature range. The MAX4173 is available in a tiny SOT23 package; it features 3mV maximum offset and an internal 12k Ω load resistor to convert its current output to a voltage output. The MAX4073 is similarly available in a tiny SC70 package. All three devices also have high signal bandwidths, making them attractive solutions within analog control loops.

The voltage-input, current-output feature of these devices enables one to leverage them in a wide variety of

clever circuits. One can, for example, use two unidirectional current-sense amplifiers—such as MAX4172 or MAX4173—to build a fast bidirectional current-sense amplifier (**Figure 2**).

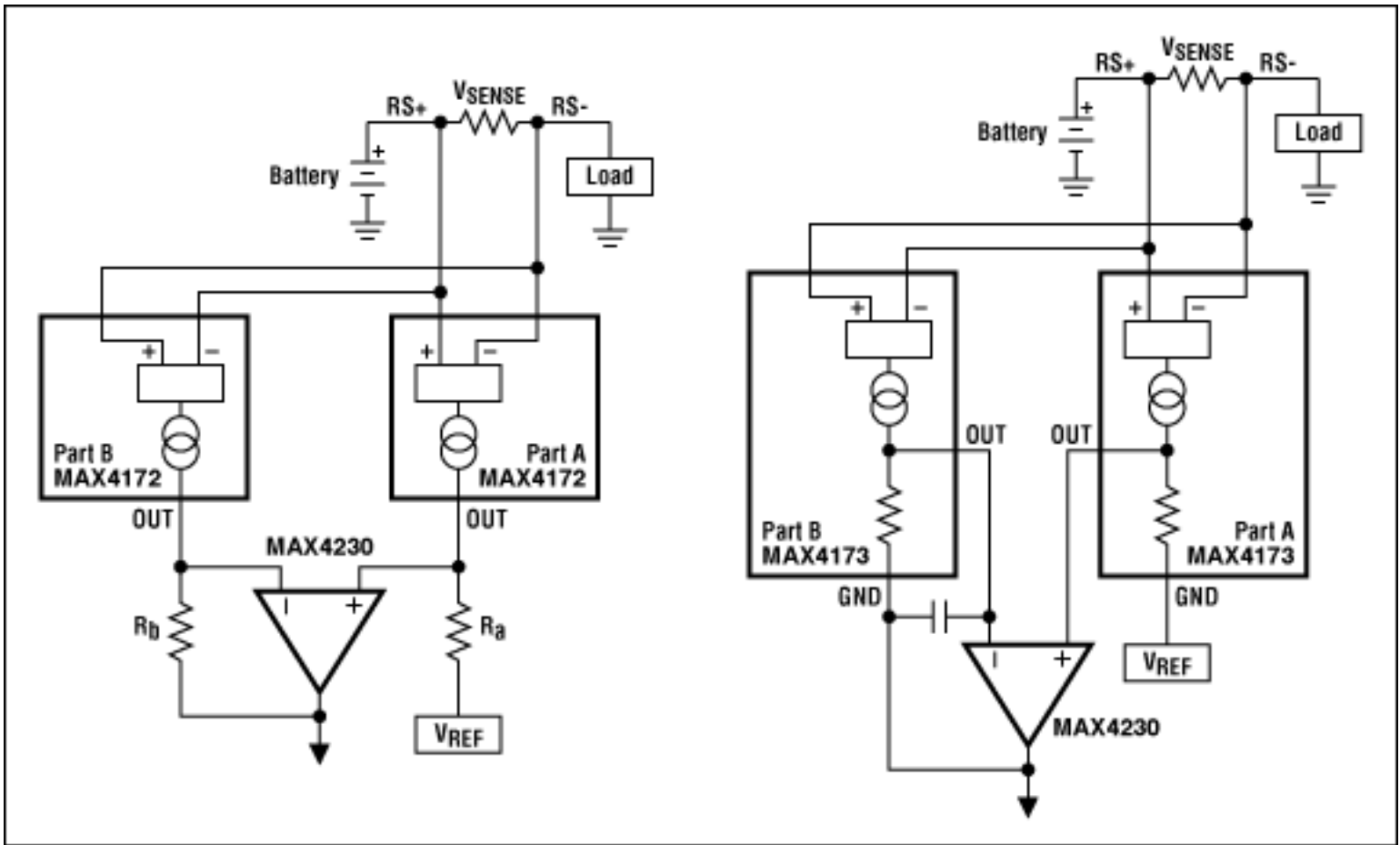

Figure 2. Two circuits showing bidirectional current-sense applications created from two unidirectional current-sense amplifiers.

Part A is active when $V_{RS+} > V_{RS-}$ (i.e., when the battery is supplying the load current) and Part B is active when $V_{RS-} > V_{RS+}$ (i.e., when the battery is being charged by the AC adapter). A general purpose op-amp combines the output currents from the two amplifiers into an appropriate output voltage. V_{REF} sets the output voltage at zero current (zero-sense voltage). The output voltage increases above V_{REF} when Part A is active and decreases below V_{REF} when Part B is active. By using $R_a \neq R_b$ in the MAX4172 circuit, different gains can be used for positive (discharging) currents and negative (charging) currents.

The MAX4173 circuit uses a 1nF capacitor in its feedback to stabilize the control loop. Since the GND pin of Part B is modulated by the output of the op-amp, the V_{CC} applied to the MAX4173 should be at least 3V above the maximum output of MAX4230. This value ensures sufficient supply-voltage headroom for proper operation of the device).

Transfer characteristics for both MAX4172 and MAX4173 circuits are provided in **Figure 3** and **Figure 4**, respectively.

Conditions for MAX4172 circuit are:

$$V_{BAT} = 8V$$

$$V_{CC} = 3.3V \text{ for MAX4172 and MAX4230}$$

$$R_a = R_b = 1k\Omega$$

$$V_{REF} = 1.2V$$

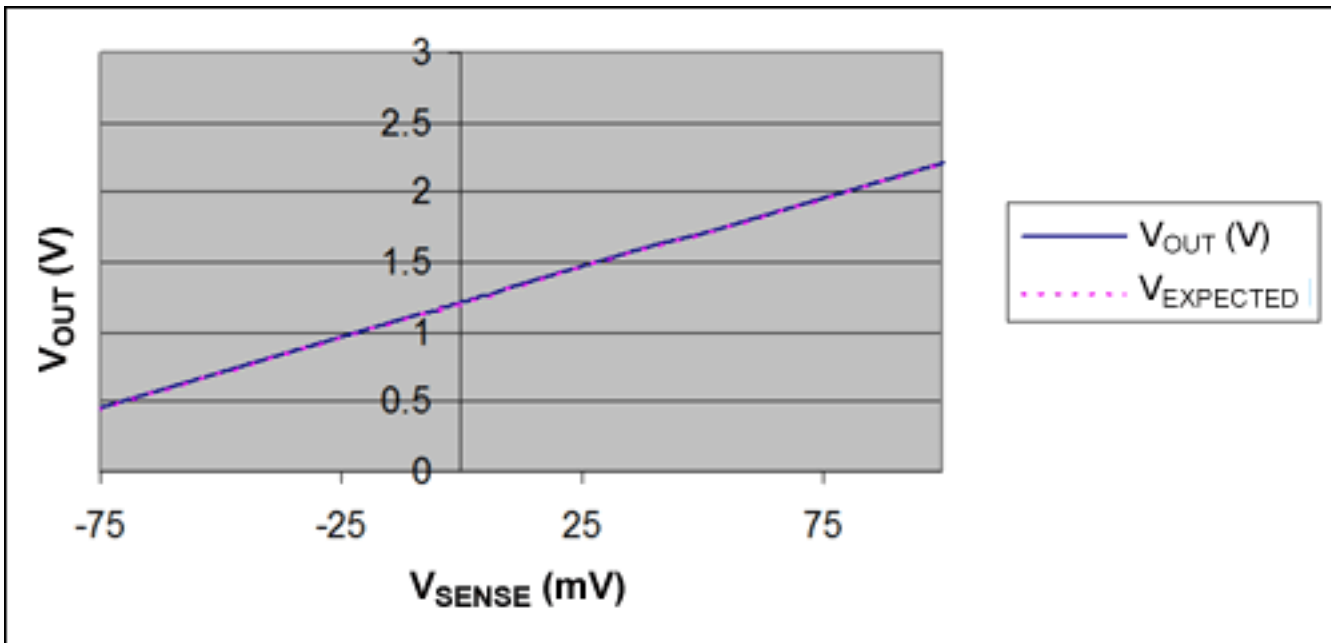

Figure 3. The transfer characteristic of a MAX4172 circuit.

Conditions for MAX4173 circuit are:

$$V_{BAT} = 8V$$

$$V_{CC} = V_{BAT} \text{ for MAX4173}$$

$$V_{CC} = 5V \text{ for MAX4230}$$

$$V_{REF} = 1.5V$$

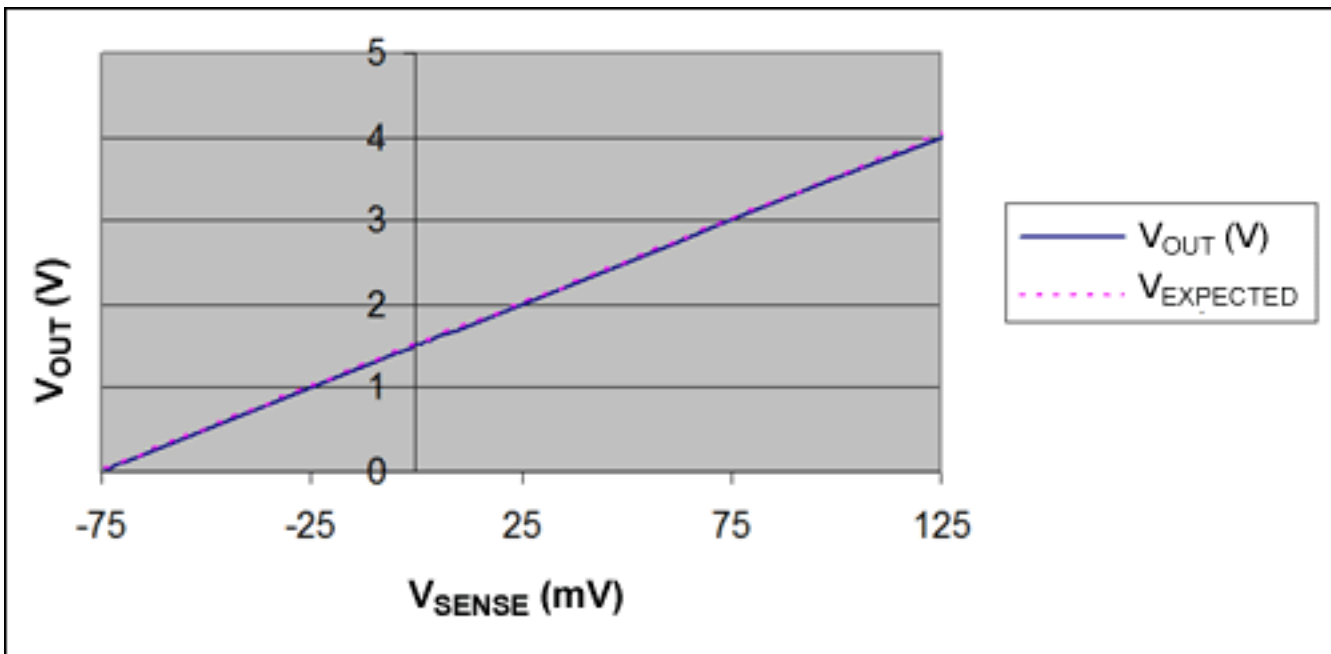

Figure 4. The transfer characteristic of a MAX4173 circuit.

Maxim also offers integrated bidirectional current-sense amplifiers:

- [MAX4081](#): 76V bidirectional current-sense amplifier
- [MAX4069–MAX4072](#): 24V bidirectional current-sense amplifier with/without internal reference

μMAX is a registered trademark of Maxim Integrated Products, Inc.

Application Note 3906: www.maxim-ic.com/an3906

More Information

For technical support: www.maxim-ic.com/support

For samples: www.maxim-ic.com/samples

Other questions and comments: www.maxim-ic.com/contact

Automatic Updates

Would you like to be automatically notified when new application notes are published in your areas of interest?

[Sign up for EE-Mail™.](#)

Related Parts

MAX4069: [QuickView](#) -- [Full \(PDF\) Data Sheet](#) -- [Free Samples](#)

MAX4073: [QuickView](#) -- [Full \(PDF\) Data Sheet](#) -- [Free Samples](#)

MAX4080: [QuickView](#) -- [Full \(PDF\) Data Sheet](#) -- [Free Samples](#)

MAX4081: [QuickView](#) -- [Full \(PDF\) Data Sheet](#) -- [Free Samples](#)

MAX4172: [QuickView](#) -- [Full \(PDF\) Data Sheet](#) -- [Free Samples](#)

MAX4173: [QuickView](#) -- [Full \(PDF\) Data Sheet](#) -- [Free Samples](#)

AN3906, AN 3906, APP3906, Appnote3906, Appnote 3906

Copyright © by Maxim Integrated Products

Additional legal notices: www.maxim-ic.com/legal