

Design Note:

HFDN - 42.0

Rev.3; 06/08

USING THE MAX3643 LASER DRIVER WITH A LOW-COST
MICROCONTROLLER



Maxim Integrated Products

Using the MAX3643 with a Microcontroller

1 Introduction

The MAX3643 compact burst mode laser driver is designed for PON (Passive Optical Network) applications such as that shown in Figure 1. There are many different types of PON networks in deployment such as APON, BPON, GPON, GEAPON and EPON. The specifics of each of these types of PONs is not important to this discussion other than noting that they all share a few common qualities with respect to the laser driver needed in the ONT (Figure 2). The general requirements are:

1. The laser driver IC must be able to bias and start modulating a laser (burst on a laser) in a very short time frame. It must also turn off the laser (burst off) quickly. For some of these PON applications the driver must accomplish this in just a few nanoseconds.
2. The laser driver IC needs to be able to modulate the laser at hundreds of Megabits or even Gigabit data rates.
3. The Laser driver and all other components in the PON network must be very low cost. The pricing pressure is particularly strong for the ONT due to the high volumes and consumer usage.

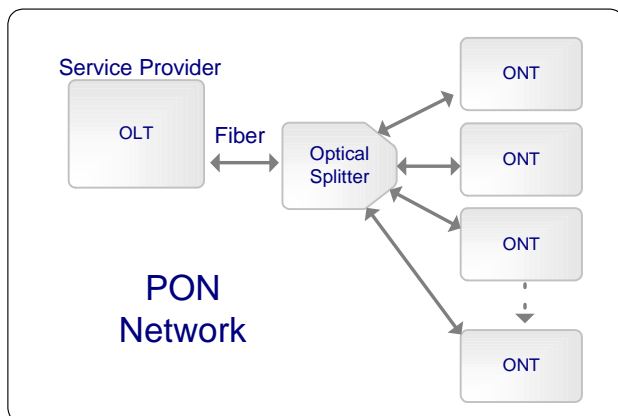

Figure 1. Simplified PON Network Diagram

With the price pressure being so strong for the ONT, high levels of integration and careful scrutiny of every component in the transceiver must be done. The MAX3643 offers some customers the potential of a lower cost system by allowing them to use already available microcontroller (μ C) features (available in a physical layer controller or a MAC layer controller) to adjust the laser currents. The total driver and controller costs can be reduced by taking the laser controller circuits out of the laser driver, which is typically done on a high-speed BiPOLAR or BiCMOS process (for best high-speed performance), and placing the control into a low-cost CMOS μ C.

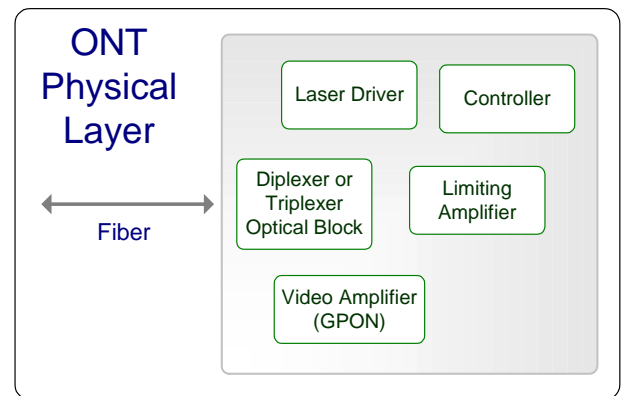

Figure 2. Typical ONT Physical Layer

This application note discusses some common techniques for digital laser control that can be incorporated into a low-cost microcontroller (μ C) or an available system controller. Examples and test data will also be provided showing the typical performance of such methods. A complete driver/controller solution with additional details, firmware and test data will also be made available in the fall of 2006.

2 Common Laser Controls

Due to the temperature related variations in the operating points of laser diodes, the bias and modulation currents delivered to the laser are normally updated based on either temperature or monitor diode feedback. The MAX3643 laser driver provides the large modulation and bias currents (up to 85mA / 70mA respectively) and also the high speed burst and modulation circuitry that are needed for the laser. The μC will then interface to the driver and adjust the bias and sometimes the modulation currents as temperature changes. Two common methods for controlling the bias and modulation currents of a laser are APC Loops and K-factor compensation. The following sections illustrate how these can be accomplished with the resources available in a low-cost μC . Interfacing μC PWM outputs to the MAX3643 will also be discussed.

2.1 Setting Laser Bias and Modulation Currents using a PWM Output

The MAX3643 was designed to interface with a variety of controller output types (voltage, current or resistance). A true voltage or current DAC output is preferred as they have less noise and startup issues

but are often included only on expensive μCs . For low-cost applications a pulse-width modulated (PWM) output can be interfaced to the MAX3643 (Figure 3) and set the output current levels. The PWM output is translated to a voltage output, essentially creating a DAC by passing the PWM signal through a low pass filter (Figure 4).

The PWM output is typically generated using a counter/timer a system clock and a register that stores the desired pulse width. The counter begins counting up with the output set to the initial condition (either a zero or a one). At each clock cycle the counter/timer output is compared to the pulse width value. If there is a match the output toggles and is held until the counter/timer reaches terminal count. The output then toggles again back to the initial condition.

This feature can be generated using internal registers of the μC ; however even very low cost μCs will often have built in counters and timers for generating PWM output signals using a variety of counting and output techniques.

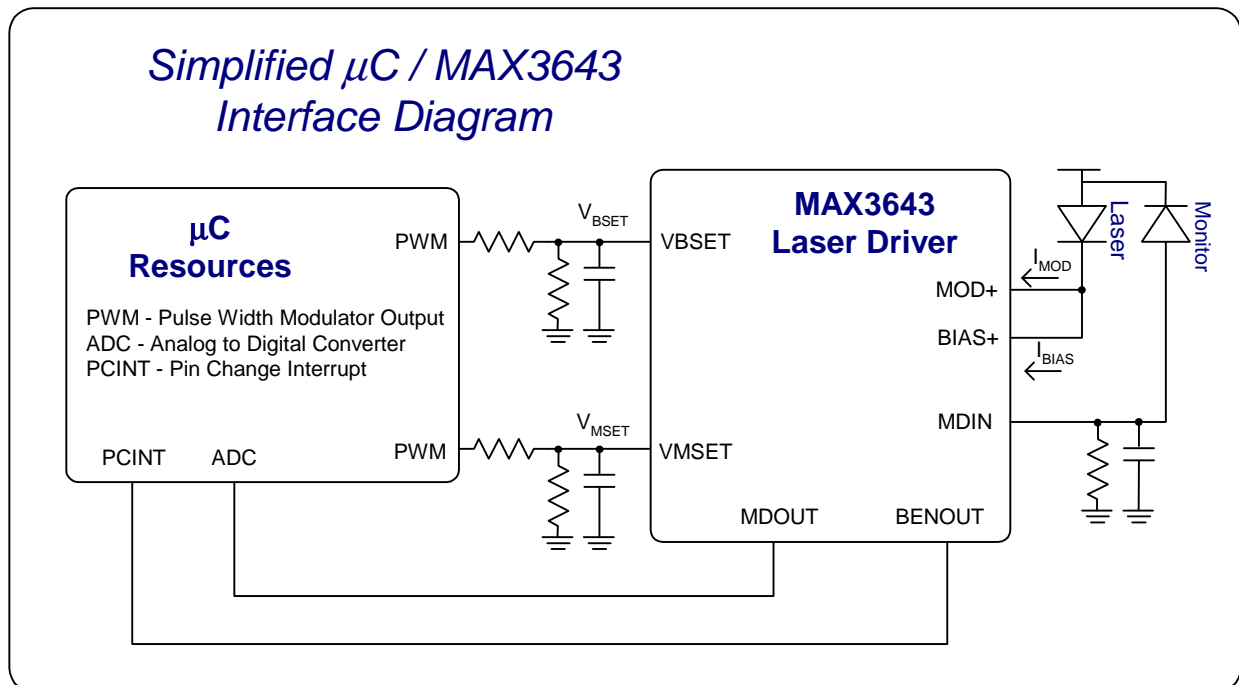

Figure 3. Simplified μC / MAX3643 Interface Diagram

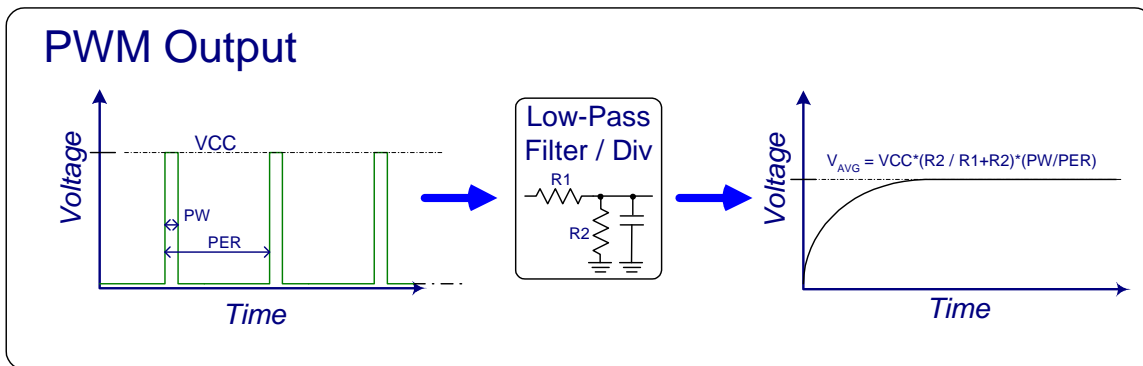

Figure 4. PWM Output to DC voltage conversion

The values of the R and C component in the low-pass filter are selected to minimize ripple/noise from the digital PWM output. The equations for selecting these components are generally provided in the data sheet for the μ C. For the context of this application note it is sufficient to simply state that ripple from the PWM output should be minimized as much as possible, and that the voltage (average or ripple peak) should not exceed 1.4V when interfaced to the MAX3643. If there is excessive ripple the laser output eye diagram will be noisy and the system bit error ratio performance will be reduced. Voltage greater than 1.4V can cause improper operation of the MAX3643.

2.2 PWM Compensation

Using the PWM output is a simple digital method for adjusting the laser bias and modulation currents of the laser through the MAX3643. The usual PWM

DAC output however is non-ideal and may need to be compensated for changes in the power supply voltage. This is not an issue for the bias current since it controlled through a closed loop (as will be explained in the next section), but it can have a dramatic affect on the overall performance due to changes it can create in the modulation current as VCC changes.

Some PWM outputs can rail between a stable reference and GND but most are simple CMOS output cells which rail between VCC and GND. For these types of PWM outputs there will be a large change in the average voltage at the output of the low pass filter as VCC changes. This change is illustrated in Figure 5. From the example shown, the average voltage would be 0.3V at VCC = 3.0V and 0.36V when VCC = 3.6V. To compensate for the variation in this example the pulse width had to be changed from 5 μ s to 6 μ s.

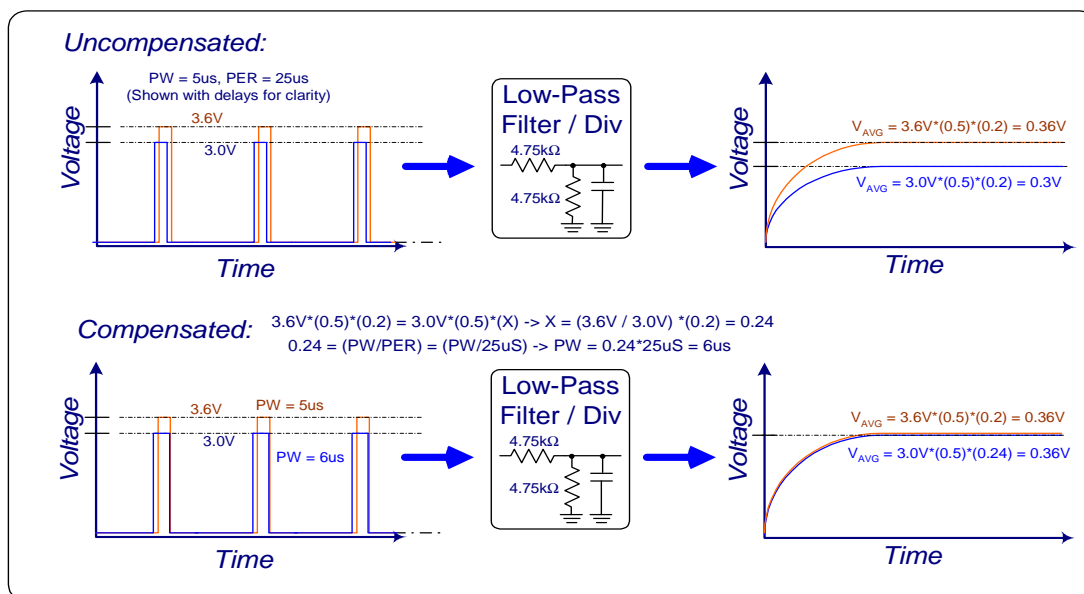

Figure 5. Uncompensated vs. Compensated PWM

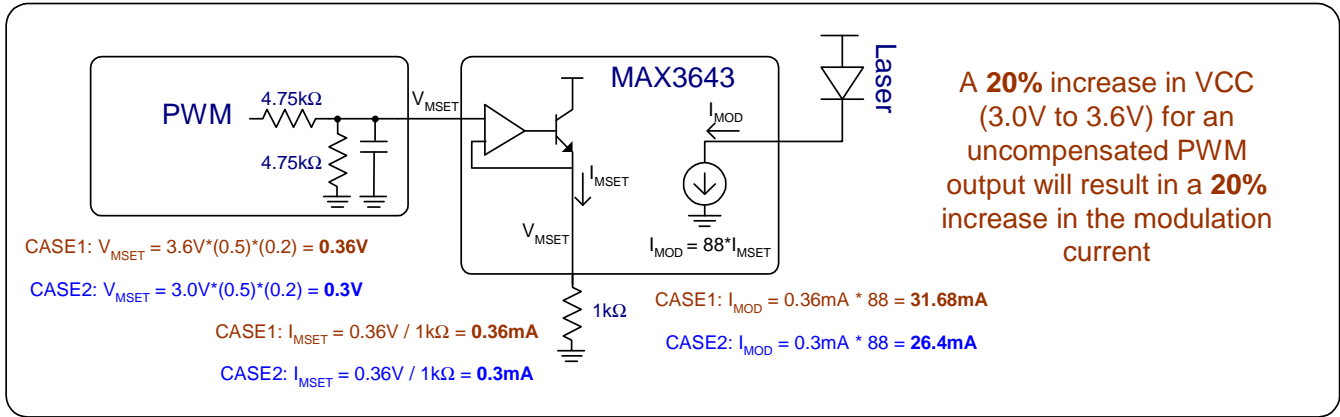

Figure 6. VCC Variation

Figure 6 shows the logical conclusion that a 20% increase in VCC will lead to a 20% increase in the laser current. Assuming that the average power was held constant by the APC loop, the extinction ratio would be approximately 11dB at 3.6V and 7.7dB at 3.0V. This much variation in the extinction ratio would be far from acceptable in a transceiver application. To decrease the variation you could: 1. regulate the supply voltage to keep the variation minimal, 2. use a PWM output with a stable (or reference) logic high output level, or 3. compensate the pulse width output as VCC changes.

Compensating the PWM is generally the cheapest and easiest solution to accomplish in a low-cost μC . A simple method is to monitor VCC and then apply a correction factor based on percentages back to the PWM output. For example if the supply voltage was 3.0V and you were normalizing everything to the 3.6V value, you would increase the pulse width by 20% ($3.6/3.0 = 1.2$) to keep the average value constant. A generalized block diagram and example of this method is shown in Figure 7.

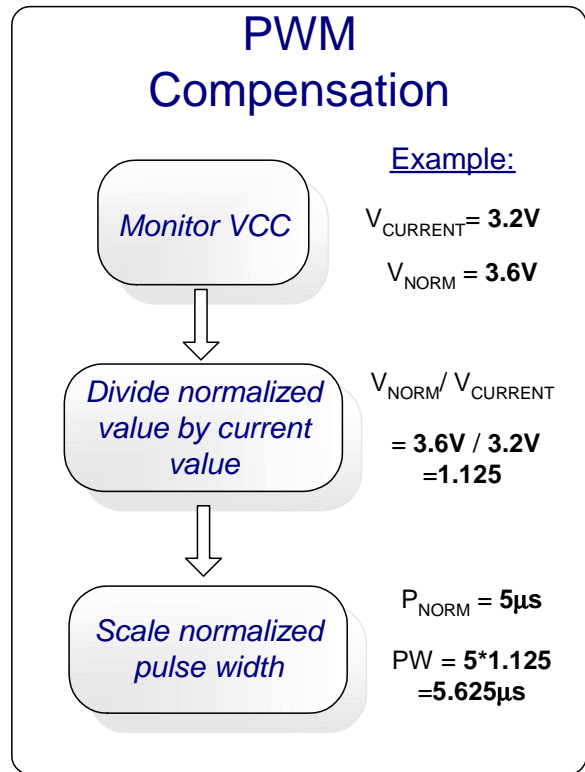

Figure 7. PWM Compensation

2.3 Automatic Power Control Loop

The bias current at elevated temperatures will often be two or more times the value at nominal temperatures. Feedback loops are often used to compensate for these changes and set the bias level. By properly setting the laser bias level the average power can be held constant over temperature. The feedback loops used in laser control are often called Automatic Power Control (APC) loops.

The APC loop consists of a monitor diode, the controller device and the bias current adjustment circuitry (Figure 3). The APC loop works to maintain the monitor diode current at a constant level by adjusting the bias current up or down as needed. Since the monitor diode current is basically proportional to the laser output power, the average optical output power is held constant by keeping the monitor diode current at a constant level.

The APC loop design is slightly more complicated for PON applications. The laser is only on for a small percentage of the time and the burst time can have a very short duration. In some PON applications the duration of a burst is less than 400ns. The MAX3643 helps to simplify APC loop design with low-cost controllers by providing a sample and hold of the monitor diode current. The monitor diode current is sampled while the laser is on. The sampled value is then output on the MDOUT pin once the laser is off. The MAX3643 holds the value long enough for a low-cost μC to do an analog to digital conversion. The μC will receive an interrupt (BEN) from the MAX3643 indicating that a sample is ready on MDOUT.

The controller must then do an ADC conversion on the voltage at MDOUT, some averaging and a decision based on the desired monitor diode current (Figure 8). The controller will then adjust the bias current up or down as needed to try and match the desired monitor diode current (set point) with the actual monitor diode current. The advantage of a closed loop such as this is that it will adjust the bias current for temperature variation but it will also adjust the bias current PWM frequency as VCC changes.

The monitor diode current will vary quickly and will often track variations in the average power due to the data pattern. For this reason the averaging and filtering used in the μC should be carefully

calculated. If the loop bandwidth is too fast the average power will drift due to changes in the data pattern. If it is too slow the initialization time may be excessive. PID controller topologies or dual / adjustable loop bandwidth systems can be used in the μC to get the best overall response at startup and normal operation.

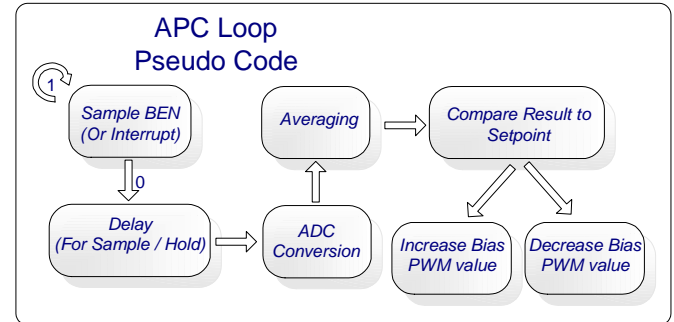

Figure 8. GPON ONT Video Overlay Block Diagram

2.4 K - Factor Compensation

The modulation current of a laser diode must often be changed as temperature changes to maintain the desired extinction ratio. Closed loop topologies that maintain a constant extinction ratio are difficult to implement without adding excessive cost to the optics. Changes in the monitor diode tracking and gain changes in the feedback loops (in low-cost optics) increase the difficulty and introduce inaccuracies and errors in the operation. For these reasons open loop methods are often used to compensate the modulation current of a laser diode over temperature.

A simple open loop method is known as K-factor compensation (Patent Pending, Application Number 10/086, 162). K-factor compensation is done by taking a calibrated constant (K, typically between 0 and 3) and multiplying this value times the bias current value. The result is then added to the modulation current setpoint. Since the APC loop will cause the bias current to increase with increasing temperature, the modulation current will also increase. Implementation in a μC is very simple as it just involves a scaling factor and an addition. For additional information on K-factor compensation please see application notes [HFAN 2.2.1 – Maintaining the Extinction Ratio of Optical Transmitters Using K-Factor Control](#), [HFAN 2.3.1 – Maintaining Average Power and Extinction Ratio](#)

[Part 1, Slope Efficiency and Threshold Current](#) and [HFAN 2.3.2 – Maintaining Average Power and Extinction Ratio, Part 2, MAX3863 Laser Driver and DS1847 Digital Resistor.](#)

3 Example Data

The following data was obtained using the MAX3643 interfaced to a laser diode and the low-cost Atmel ATtiny13V-10MU microcontroller. The test data illustrates performance results of the methods explained in the preceding text. Transmitted data is bursted for all tests, the burst data block consist of PRBS pattern data transmitted at 1.25Gbps.

The performance of the APC loop can be seen in Figure 9 which shows the average output optical power as the temperature was varied from -40°C to +85°C. In this test the average power varied by less than +/- 0.5dB which is well within the tracking error variation of the laser diode (+/- 1.5dB).

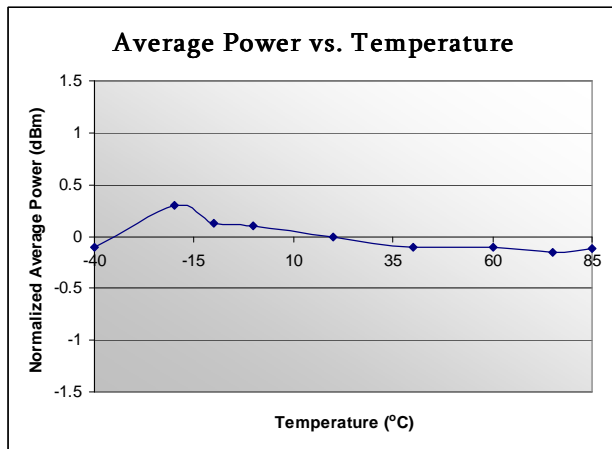

Figure 9. APC Loop Performance

The K-factor compensation performance is shown in Figures 10 – 15. In Figure 11 the performance is highlighted by measuring extinction ratio as the temperature is changed from 0°C to 70°C. As seen in Figure 10 the extinction ratio varied by less than 1dB over temperature, which is very good performance for an open loop method. The extinction ratio over the extended temperature range (-40°C to 85°C) is shown in Figure 11. Over this range there is more variation, in particular from -40°C to 0°C and this is partly due to tracking error of

the laser diode and the calibration method used for the K-factor compensation.

If you are designing a module that operates over this temperature range you may want to consider some additional methods to reduce the extinction ratio variation such as: 1. change the calibration point to allow for more variation at high temperature but less at low temperature (less variation overall), 2. change the K factor equation to include an additional temperature dependent term, or 3. add a temperature sensor and associated equations which adjust the K-factor value at low temperatures.

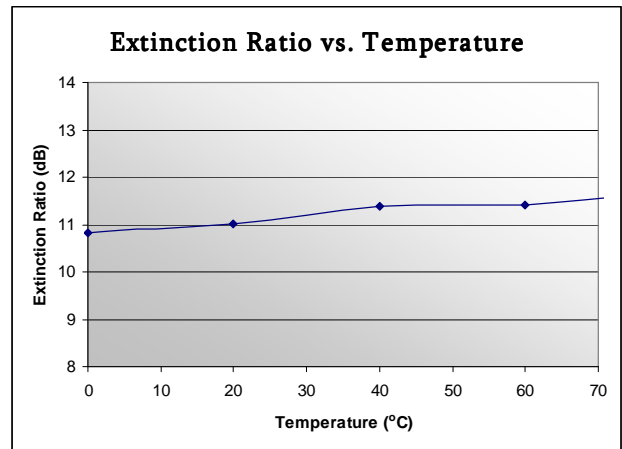

Figure 10. Extinction Ratio (0°C to 70°C)

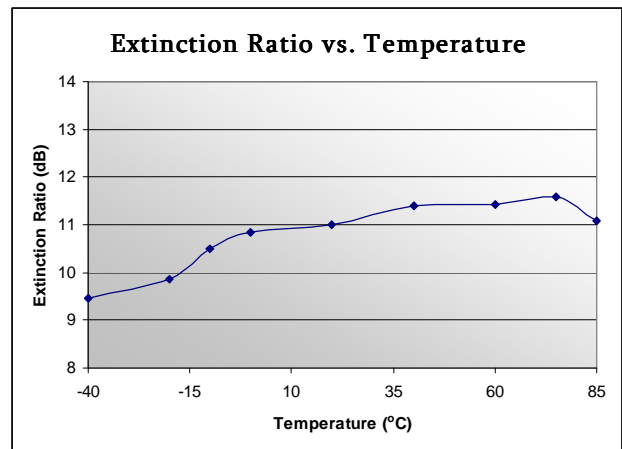

Figure 11. Extinction Ratio (-40°C to 85°C)

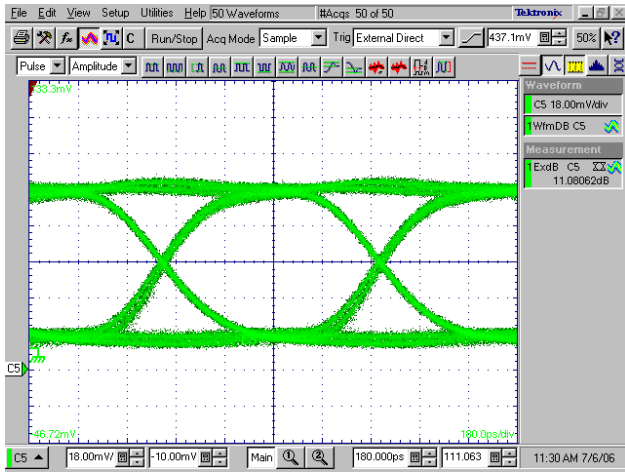

Figure 12. Eye Diagram, Temp = +85°C

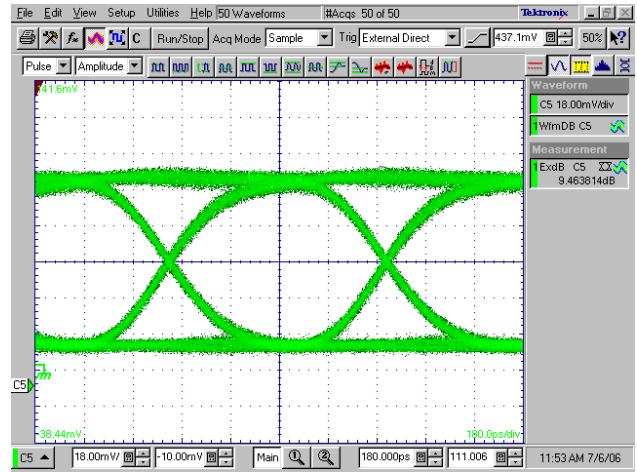

Figure 15. Eye Diagram, Temp = -40°C

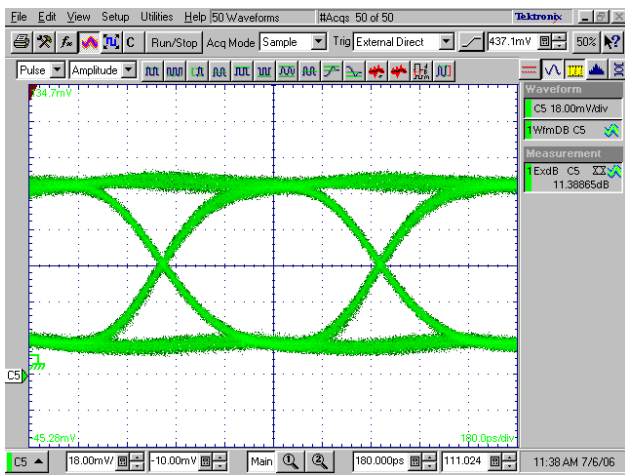

Figure 13. Eye Diagram, Temp = +40°C

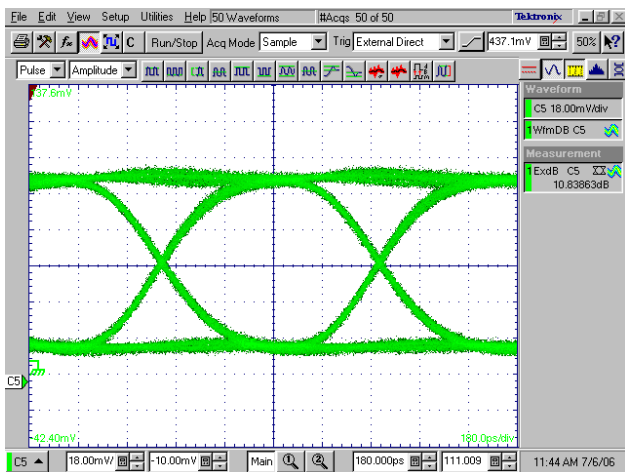

Figure 14. Eye Diagram, Temp = 0°C

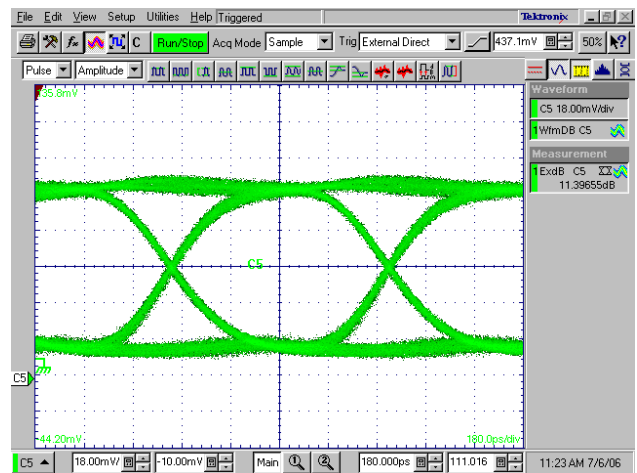

Figure 16. Room Temp, VCC = 3.0V

A PWM compensation algorithm was also implemented in the uC to compensate for variations in VCC. The performance of the PWM compensation is shown in Figures 16 – 18 and in Table 1. As seen in these figures and tables, the variation was less than 0.6dB as VCC was varied between 3.0V and 3.6V.

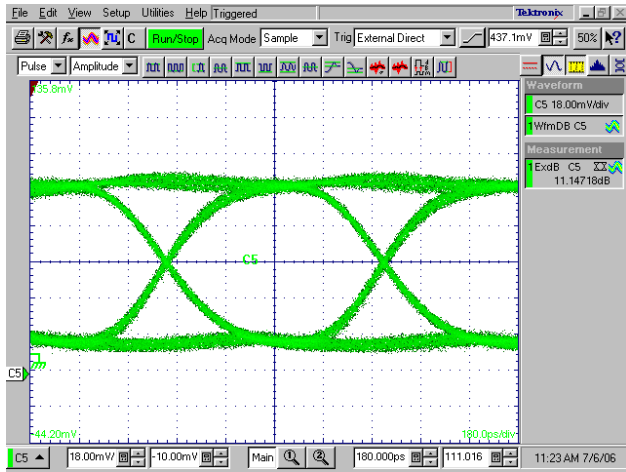

Figure 17. Room Temp, VCC = 3.3V

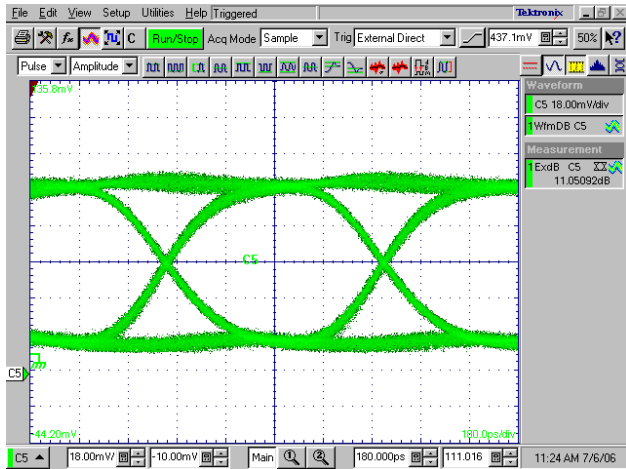

Figure 18. Room Temp, VCC = 3.6V

Table 1, Extinction Ratio vs. Temp and VCC

| VCC | +85 °C | +25 °C | -40 °C |
|------------------|-----------------|-----------------|-----------------|
| 3.0V | 11.56dB | 11.39dB | 9.42dB |
| 3.3V | 11.27dB | 11.15dB | 9.46dB |
| 3.6V | 11.03dB | 11.05dB | 9.08dB |
| Variation | = 0.53dB | = 0.34dB | = 0.38dB |

4 Conclusion

Applying simple methods and basic resources available in a low-cost μC (that are interfaced to the MAX3643) the average power and extinction ratio of laser diodes can be well controlled over temperature change and VCC variations.