



APPLICATION NOTE 3884

How Far and How Fast Can You Go with RS-485?

Abstract: Designers of industrial datacom systems often ask, what is the most cost-effective implementation for multidropped, medium-speed, serial data communications? What data rates can be reliably achieved over what distance, and how? The design trade-off has always been less distance at a higher rate, or greater distance at a lower rate. So, the crucial question is: how far can you reliably transmit and receive data at a specified data rate? The MAX3469 is used to demonstrate RS-485 performance.

Introduction

The various serial-datacom protocols range from RS-232 to Gigabit Ethernet, and beyond. Though each protocol suits a particular application, in all cases you must consider cost and performance of the physical (PHY) layer. This article focuses on the RS-485 protocol and the applications best suited to that standard. It also shows the ways that you can optimize data rates as a function of cabling, system design, and component selection.

Protocol Definitions

What is RS-485? What is Profibus? How do they compare to other serial protocols, and for what applications are they best suited? To answer these questions, the following overview compares the characteristics and capabilities of the RS-485 PHY with those of RS-232 and RS-422.^[1] (Throughout this article, RS refers to the respective ANSI EIA/TIA standards.)

RS-232 is a standard that originated as a communications guide for modems, printers, and other PC peripherals. It provided a single-ended channel with baud rates to 20kbps, later enhanced to 1Mbps. Other RS-232 specifications include nominal $\pm 5V$ transmit and $\pm 3V$ receive (space/mark), 2V common-mode rejection, 2200pF maximum cable load capacitance, 300 Ω maximum driver output resistance, 3k Ω minimum receiver (load) impedance, and 100ft (typical) maximum cable length. RS-232 systems are point-to-point, not multidroppable. Any RS-232 system must accommodate these constraints.

RS-422 is a unidirectional, full-duplex standard for electrically noisy industrial environments. It specifies a single driver with multiple receivers. The signal path is differential, and handles bit rates above 50Mbps. The receivers' common-mode range is $\pm 7V$, the driver output resistance is 100 Ω maximum, and the receiver input impedance can be as low as 4k Ω .

The RS-485 Standard

RS-485 is a bidirectional, half-duplex standard featuring multiple 'bussed' drivers and receivers, in which each driver can relinquish the bus. It meets all RS-422 specifications, but is more robust. It has a higher receiver-input impedance and larger common-mode range (-7V to +12V).

Receiver input sensitivity is $\pm 200mV$, which means that to recognize a mark or space, a receiver must see signal levels above +200mV or below -200mV. Minimum receiver input impedance is 12k Ω , and the driver output voltage is $\pm 1.5V$ minimum, $\pm 5V$ maximum.

Drive capacity is 32 unit loads, i.e., 32 12k Ω receivers in parallel. For receivers of higher input impedance, the number of unit loads on one bus can be higher. Any number of receivers can be connected to the bus, provided that the combined (parallel) load presented to the driver does not exceed 32 unit loads (375 Ω).

The driver load impedance is 54 Ω maximum, which, in a typical 24AWG twisted-pair environment, is 32 unit loads in parallel with two 120 Ω terminators. RS-485 has become the best choice for POS, industrial and telecom applications. The wide common-mode range enables data transmission over longer cable lengths and in noisy environments such as the floor of a factory. Also, the receivers' higher input impedance allows more devices to be dropped on the lines.

Profibus and Fieldbus^[2] are buses used mainly in industrial plants, and are an extension of RS-485. The plant wiring systems measure sensors, control actuators, collect and display data, and conduct data communications between the process control system and the network of sensors and actuators.

Note: older and existing industrial plants have a complicated wiring infrastructure that is prohibitive to replace.

Profibus and Fieldbus are the overall system descriptions; RS-485 is the standard for the PHY layer of the network supporting them. Profibus and Fieldbus have slightly different specifications. Profibus requires a 2.0V minimum differential output voltage with $RL = 54\Omega$; Fieldbus requires a minimum differential output voltage of 1.5V, with $RL = 54\Omega$. Profibus transmits at 12Mbps, vs. 500kbps for Fieldbus. Skew and capacitance tolerance are tighter in Profibus applications.

Where Do the Protocols Best Fit?

- RS-232: communication with modems, printers, and other PC peripherals. The typical maximum cable length is 100ft.
- RS-422: industrial environments that require only one bus master (driver). Typical applications include process automation (chemicals, brewing, paper mills), factory automation (autos, metal fabrication), HVAC, security, motor control, and motion control.
- RS-485: industrial environments for which more than one bus master/driver is needed. Typical applications are similar to those of RS-422: process automation (chemicals, brewing, paper mills), factory automation (autos, metal fabrication), HVAC, security, motor control, and motion control.

What Factors Limit the RS-485 Data Rate?

The following factors affect how far one can reliably transmit at a given data rate:

- Cable length: At a given frequency, the signal is attenuated by the cable as a function of length.
- Cable construction: Cat5 24AWG twisted pair is a very common cable type used for RS-485 systems. Adding shielding to the cable enhances noise immunity, and thereby increases the data rate for a given distance.
- Cable characteristic impedance: Distributed capacitance and inductance slows edges, reducing noise margin and compromising the 'eye pattern'. Distributed resistance attenuates the signal level directly.
- Driver output impedance: If too high, this limits drive capability.
- Receiver input impedance: If too low, this limits the number of receivers that the driver can handle.
- Termination: A long cable can act like a transmission line. Terminating the cable with its characteristic impedance reduces reflections and increases the achievable data rate.
- Noise margin: Bigger is better.
- Slew rate of driver: Slower edges (lower slew rates) enable transmission over longer cable lengths.

Some Empirical Data

Given the background information above, we next consider an actual wired system such as that of **Figure 1**. The cable shown is one of the most common for RS-485 systems: EIA/TIA/ANSI 568 Cat5 twisted pair. The data rates obtained for cable lengths from 300feet to 900feet range from 1Mbps to 35Mbps.

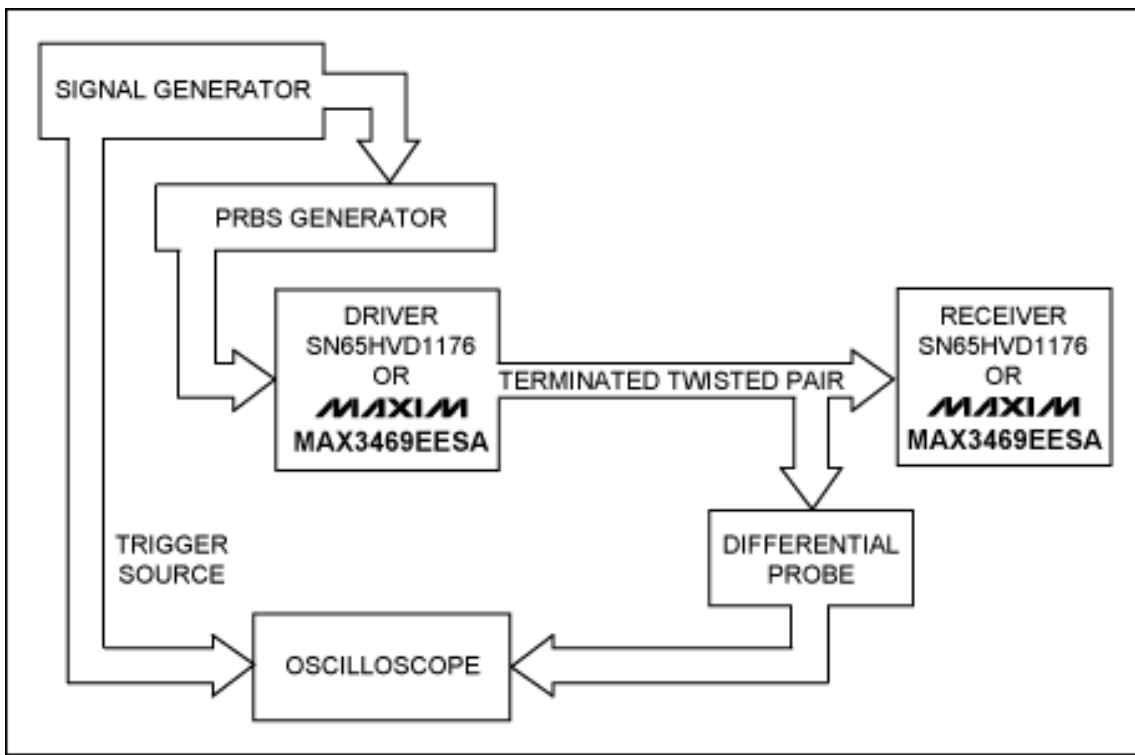

Figure 1. Test setup.

System designers often choose a driver and receiver from two competing manufacturers, but most designers are primarily interested in how far and how fast the RS-485 driver can drive a signal. The performance of a Maxim driver (the [MAX3469](#) in this case) and an equivalent driver from another manufacturer are presented in **Figures 2** and **3**.

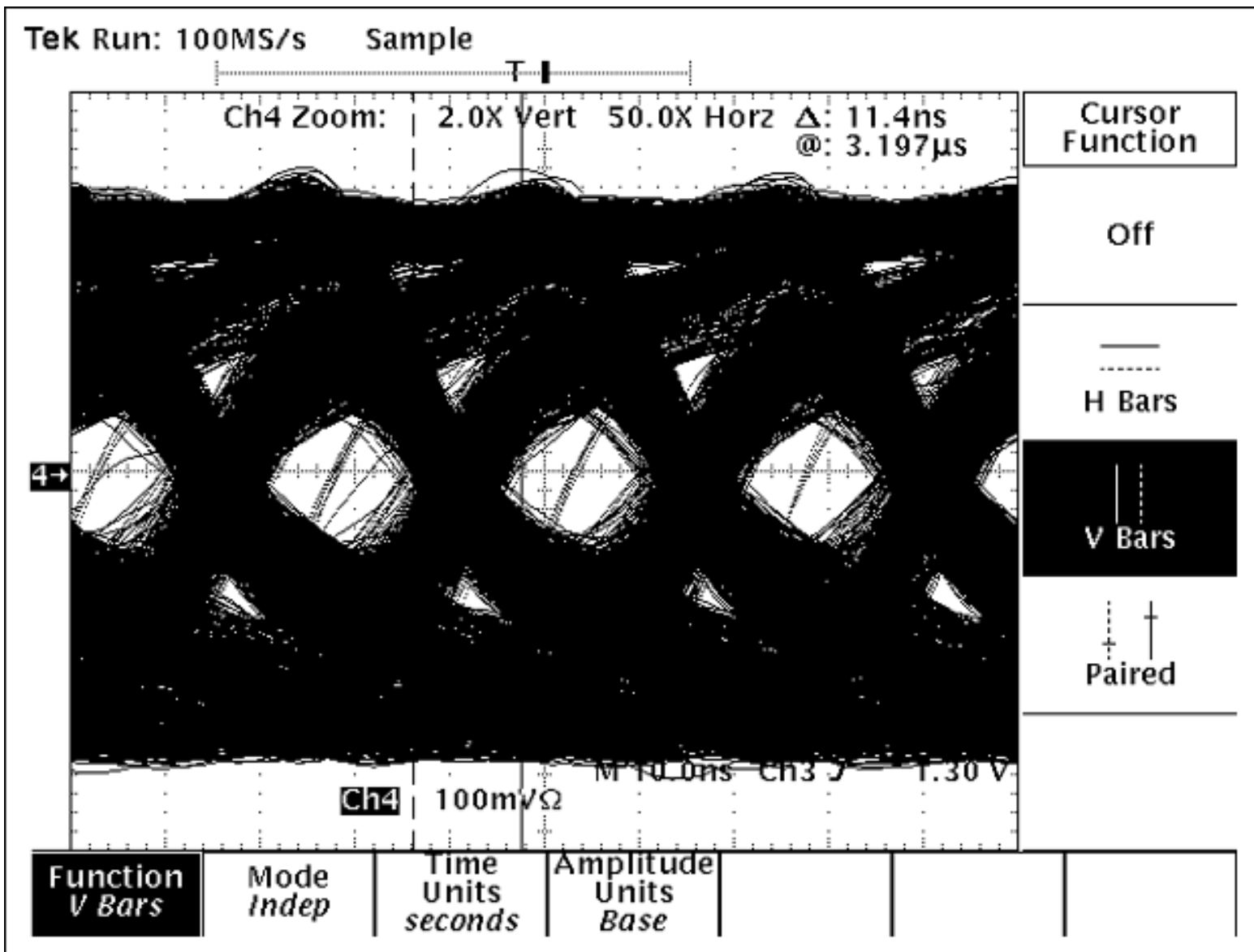

Figure 2. Eye pattern for an RS-485 driver device comparable to the MAX3469 from Maxim.^[3]

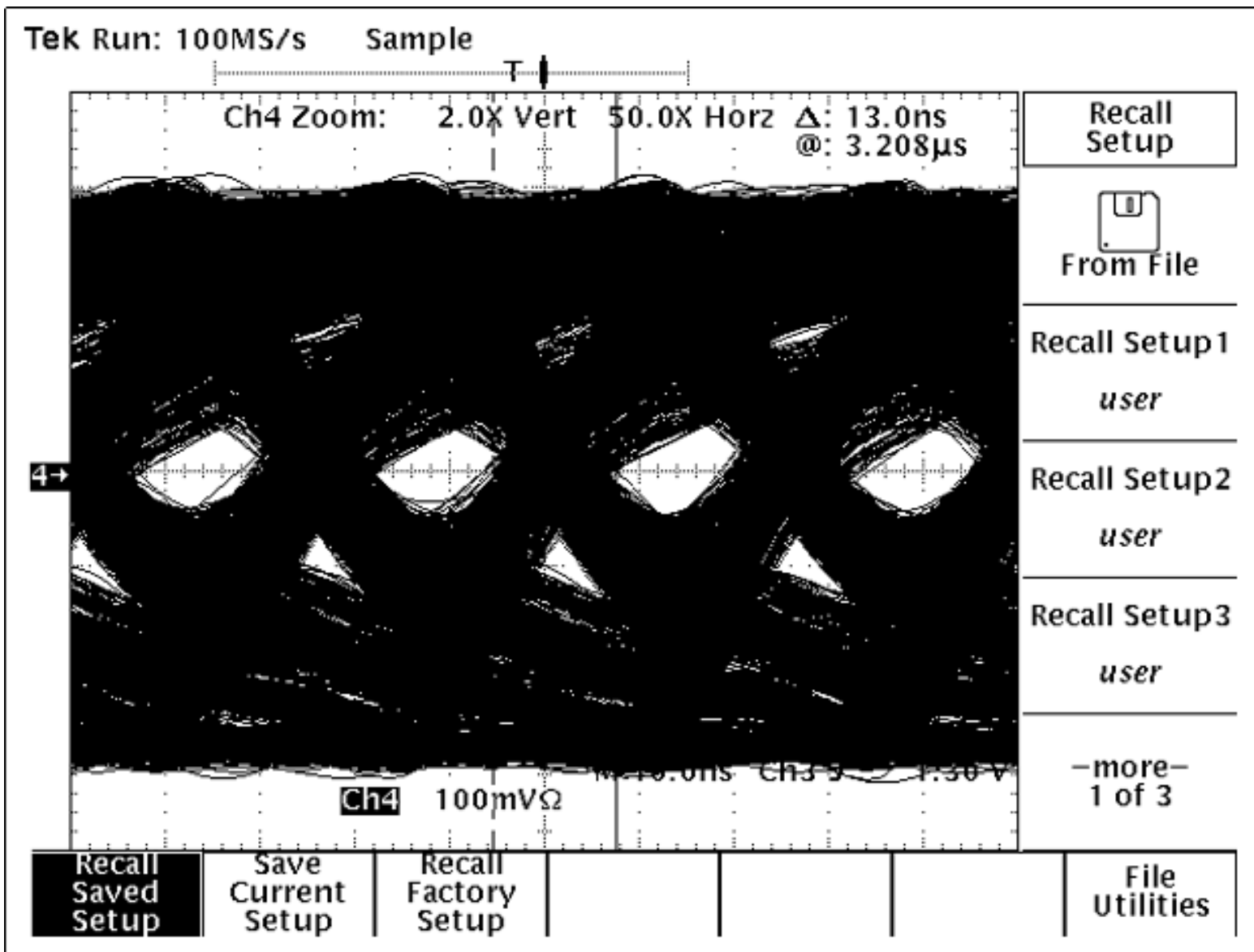

Figure 3. Eye pattern for Maxim's MAX3469.

Signal integrity is tested by observing the driver's differential output. Set the oscilloscope to look for trigger points between the 80mV and -400mV thresholds. (These thresholds are chosen because receivers have an input range of 20mV to -200mV, plus a noise margin.) Then, when pulses (bits) begin to 'run together', use eye patterns to determine the overall contributions of distortion, noise, and attenuation to the parameter called intersymbol interference (ISI).

ISI forces you to reduce the bit rate to a level that allows an adequate distinction between pulses. Tests of the Figure 1 circuit show a consistent and clear correlation between trigger points and eye patterns. The eye patterns exhibit 50% jitter, measured using methods documented in National Semiconductor's application note 977^[4]. Measuring jitter at 0V differential and $\pm 100\text{mV}$ differential yields the data shown in Figures 4 and 5.

**BIT RATE VS. CAT5 LENGTH
(JITTER MEASURED AT $\pm 100\text{mV}$)**

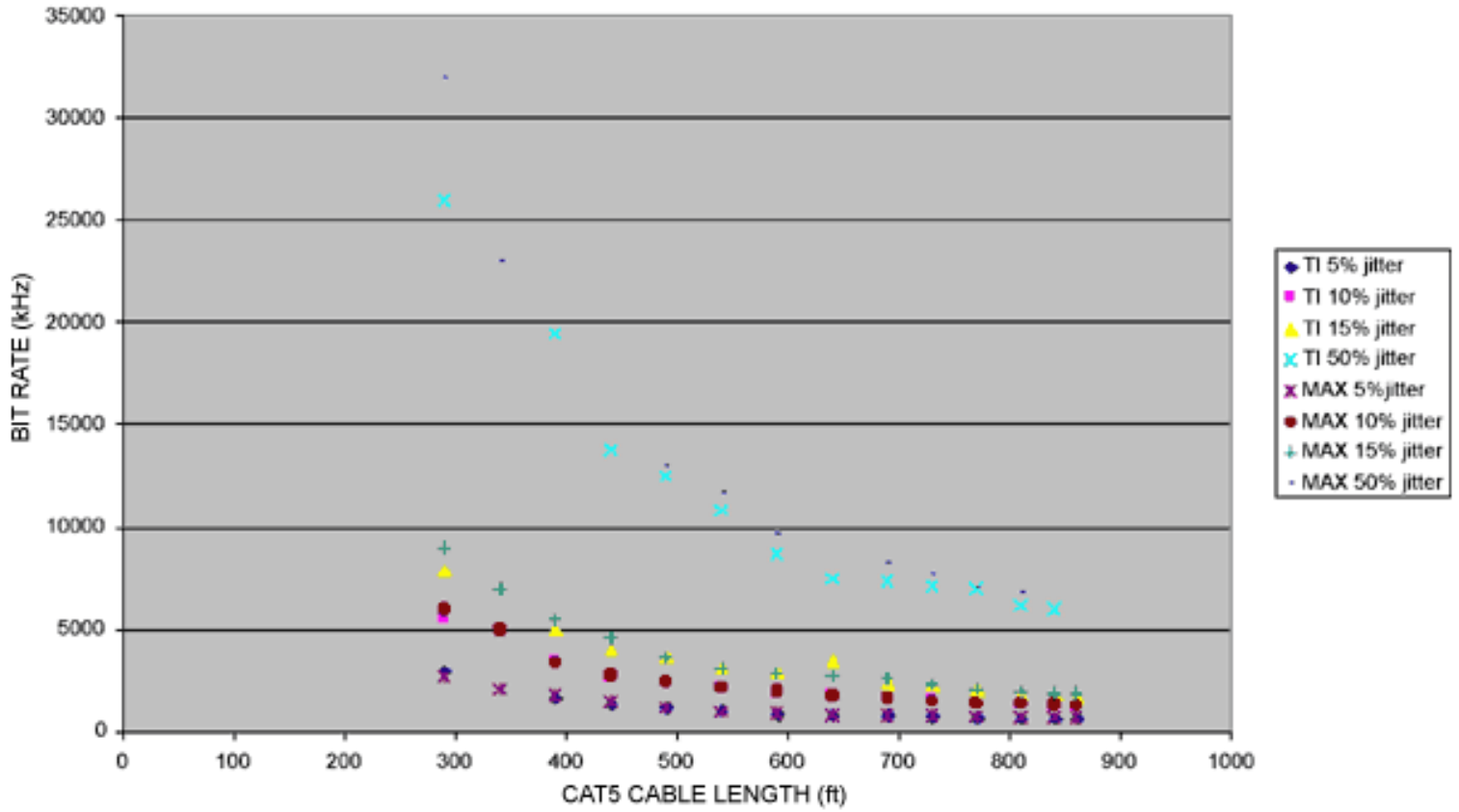

Figure 4. Graph of jitter for a given bit rate and cable length. Jitter is measured at $\pm 100\text{mV}$ differential.

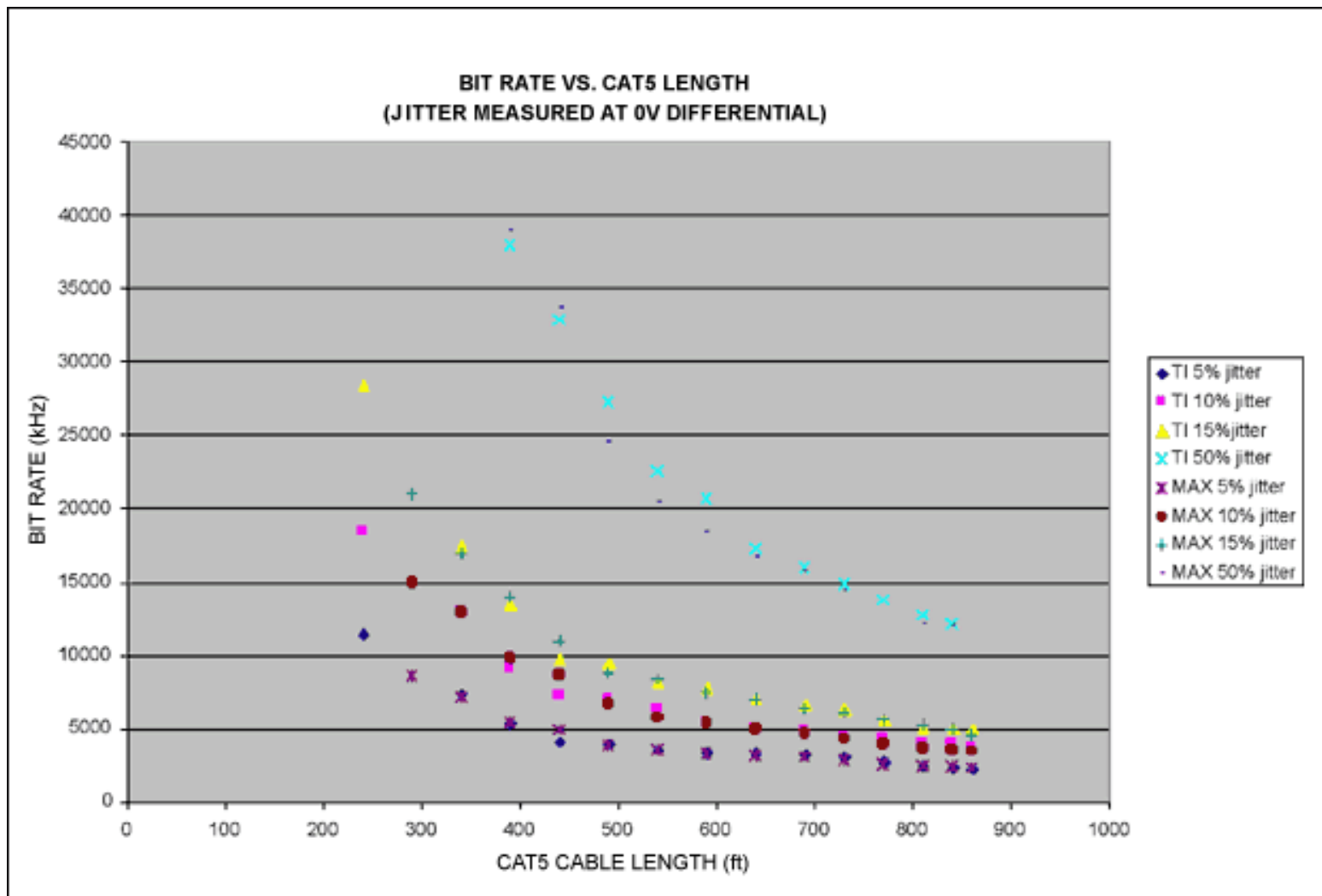

Figure 5. Graph of jitter for a given bit rate and cable length. Jitter is measured at 0V differential.

For a given point-to-point connection, the bit rate associated with a particular cable length can be illustrated at $\pm 100\text{mV}$ differential (Figure 4) or 0V differential (Figure 5). Thresholds of $+100\text{mV}$ and -100mV ensure that the receiver switches properly, because we know that they can switch correctly with differential signals greater than 200mV . (The data of Figure 5 applies only to an ideal receiver, which switches at a 0V differential input.)

Eye Diagrams and Failure Modes

At 39Mbps and 340 feet of Cat5 cable, the driver output of Figure 2 exhibits an eye pattern in which signals cross in the middle of the eye—a condition indicating possible bit errors. The Maxim device at the same data rate, however, (Figure 3) shows no such condition. The Maxim transceiver offers better performance due to symmetrical output edges and lower input capacitance.

The two drivers are comparable for the tests described above. At higher data rates over longer cable lengths, however, the Maxim driver is more robust. Figure 5 provides an estimate of how fast and how far the Maxim part can drive data in a point-to-point network. Empirically, the appearance of bit errors corresponds approximately to the 50% jitter limit.

Research Data from Various Sources

Generally accepted industry-wide maximums for distance and data rate are 4000feet and 10Mbps, but (of course) not at the same time. Combining the latest devices with careful system design, however, can provide higher throughput over longer cable lengths.

Preemphasis^[5] is a technique that improves data rate vs. distance, and is applicable to RS-485 communications (Figure 6). RS-485 transceivers without driver preemphasis or receiver equalization generally acquire 10% jitter across 1700 feet of cable when operating at a fixed data rate of 1Mbps. Adding driver preemphasis at that rate doubles the distance to

3400ft without increasing the jitter. As an alternative, preemphasis can increase the data rate for a given distance. Drivers operating at 400kbps without preemphasis generally acquire 10% jitter over 4000ft. Adding preemphasis lets you transmit up to 800kbps for that distance.

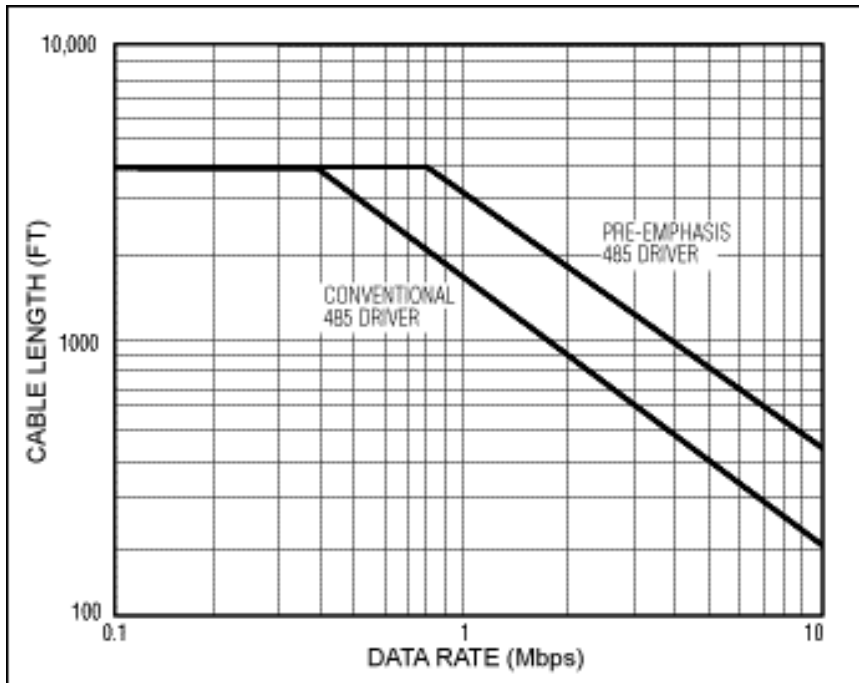

Figure 6. Data rate vs. cable length.

Another way to calculate maximum cable length for reliable transmissions is to use the attenuation vs. frequency table supplied by the manufacturer for Cat5 cable. A general rule for allowable attenuation is -6dBV over the run of cable. That value can be combined with the manufacturer's attenuation data to calculate maximum cable length for a given frequency.

Tips and Tricks

Available RS-485 transceivers have several features that can enhance system performance.

- Preemphasis (mentioned above): Reduces inter-symbol interference.
- Reduced unit-load receivers: Low-load devices are available down to 1/8 unit load, enabling up to 256 devices on one bus. Such devices also enable lower bus loading, which, in turn, allows a longer cable or higher data rate.
- High-speed devices: Currently available drivers are capable of data rates up to 52Mbps, achieved with special attention to low propagation delay and low skew.
- ESD protection: This does not enhance data rate, but can be the difference between a working system and one with a data rate of zero (broken). Available devices offer built-in ESD protection to $\pm 15\text{kV}$.
- Proper wiring^[6]: RS-485 specifies differential transmission, which requires two signal wires in addition to a ground wire (commonly a 24AWG twisted pair) to transmit the signal. The two signal wires carry signals opposite in polarity, and greatly reduce the problems of radiated EMI and EMI pickup. The common characteristic impedance of this wire is 120Ω , which is also the resistance used to terminate each end of the cable—in the interest of reducing reflections and other transmission-line effects. **Figures 7** and **8** illustrate properly wired systems.

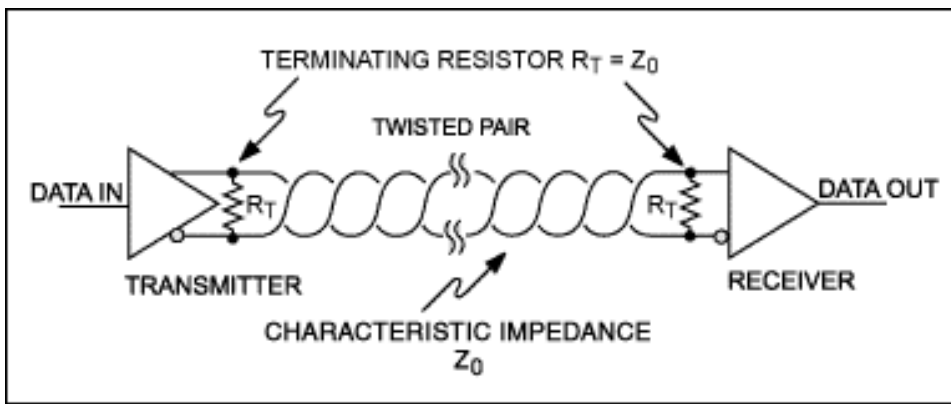

Figure 7. Single transmit, single receive network.

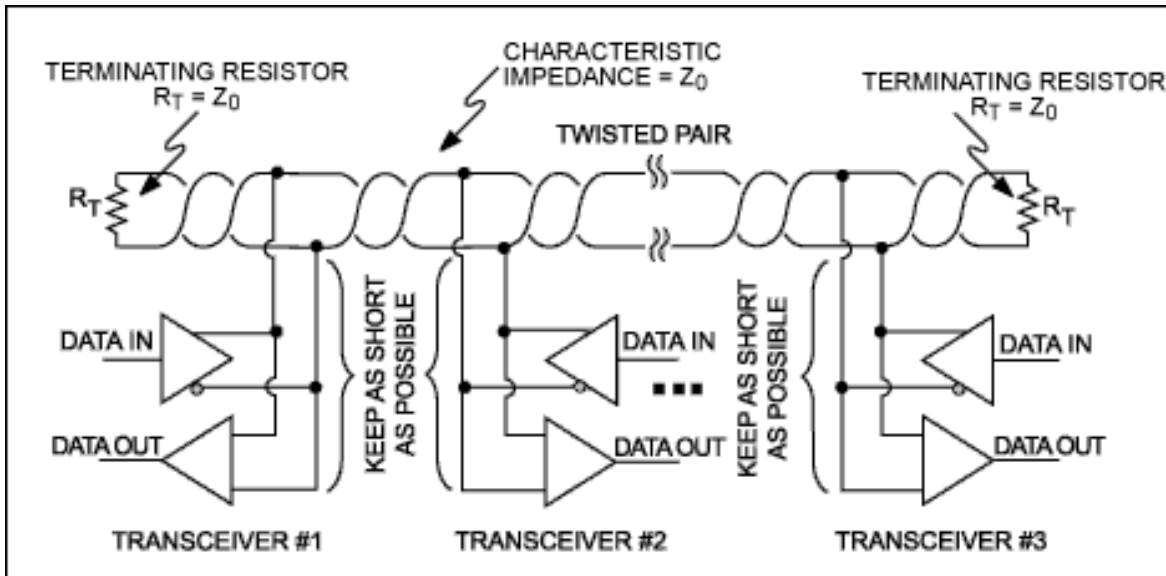

Figure 8. Multiple-transceiver network.

Conclusion

Thus, RS-485 networks can achieve reliable data transmissions in electrically noisy environments. By considering the tradeoff between data rate and cable length, you can design a system that achieves data rates in excess of 50Mbps over cable lengths of hundreds of meters, and without repeaters.

A similar article appeared in Planet Analog online on June 8, 2005.

References

1. For more general information, see the Maxim application note 736, "[RS-485 Differential Data Transmission System Basics](#)."
2. See the Maxim application note 1833, "[Using RS-485/RS-422 Transceivers in Fieldbus Networks](#)."
3. See the Texas Instruments *Databook*, "Data Transmission Circuits, Vol. 1," 1995/1996, pp. 4-9 to 4-24, and 4-37 to 4-48.
4. See National Semiconductor's application note 977, "[LVDS Signal Quality: Jitter Measurements Using Eye Patterns Test Report #1](#)," which can be found on that company's website.
5. For a more detailed discussion, see Maxim's application note 643, "[Preemphasis Improves RS-485 Communications](#)."
6. See the Maxim application note 763, "[Guidelines for Proper Wiring of an RS-485 Network](#)."

Application note 3884: www.maxim-ic.com/an3884

More Information

For technical support: www.maxim-ic.com/support

For samples: www.maxim-ic.com/samples

Other questions and comments: www.maxim-ic.com/contact

Automatic Updates

Would you like to be automatically notified when new application notes are published in your areas of interest? [Sign up for EE-Mail™](#).

Related Parts

MAX3469: [QuickView](#) -- [Full \(PDF\) Data Sheet](#) -- [Free Samples](#)

AN3884, AN 3884, APP3884, Appnote3884, Appnote 3884

Copyright © by Maxim Integrated Products

Additional legal notices: www.maxim-ic.com/legal