



## APPLICATION NOTE 3882

# EMI/EMC Suppression in Audio/Video Interfaces

*Abstract: In the past, large external filters and shielded cables were the accepted ways to address EMI/EMC (electromagnetic interference or electromagnetic compatibility) in audio/video products. These methods added cost, adversely affected performance, and increased the size of the end product. As these products have decreased in size and evolved into the modern audio/video players, the solutions have also had to decrease in size while maintaining or even improving performance. To achieve this, parts like the MAX9511 graphics video interface and MAX9705 Class D audio amplifier have been developed to deliver EMI performance while reducing solution size. To show how this was done we will look at the audio and display interfaces of a typical PC, and the EMI performance attainable with these devices despite their diminutive size. This article investigates the different EMI problems that must be solved for an audio/video interface design and the methods available to do so.*

## Introduction

All electronic products marketed worldwide undergo EMI/EMC (electromagnetic interference/electromagnetic compatibility) testing before they are offered for sale to prove that they will not create interference, or be interfered with by other devices. For testing purposes, products are grouped into two classes: intentional radiators and unintentional radiators. For example, cell phones and walkie-talkies intentionally radiate energy while TVs, PCs, or laptops should not.

Depending on the class of the product and the agencies involved, the EMI/EMC requirements vary. Regardless, EMI/EMC testing is partitioned into two general categories:

- **Emissions** This limits what amplitude and frequency a product can radiate or conduct so that the device does not interfere with others.
- **Susceptibility (also called Immunity)** This testing category compliments the Emissions requirement by limiting the amplitude and frequency of the radiated and conducted signals that can interfere with a product.

As noted above, the two ways EMI can be emitted by a device are conduction and radiation. These are related because all radiated EMI is due to current flow. However, not all current flow causes radiation. Consequently, radiated interference problems are investigated and suppressed before conducted interference issues. Of the two, radiation is more difficult to predict and suppress. Therefore, it causes most unanticipated EMI testing failures in the unintentional radiator product class. We will concentrate on solving the radiation problem in the audio/video interface found in many products.

You can use several methods to meet the limits specified in EMI/EMC regulations. However, these methods tend to fall into the general categories of shielding and filtering. In actual practice, these are combined with application-specific methods to achieve an overall EMI solution. For example, in most products, a metal chassis acts as a shield to radiation and L-C or R-C filters reduce conducted interference on the input/output wires. In addition, we might dither a clock to spread its spectrum and reduce the amount of filtering or shielding required in a specific application.

When the performance appears adequate, a product is formally tested in an approved laboratory. If it passes, it may be marketed; however, failing is a problem. Even a small change to correct a problem can take time to implement. This may delay introduction because passing EMI/EMC-compliance testing is mandatory in all international and domestic markets.<sup>1</sup> Consequently, the EMI design often degrades video performance to ensure

that a product passes these tests. This video degradation is exacerbated in modern designs by the size and cost of the parts required to pass EMI testing.

This design challenge is particularly true for the contemporary audio/video analog interface with its reduced product size and high performance expectations. The first step in solving this problem is to find where most EMI/EMC failures occur and then investigate potential solutions.

## Where Failures Happen

EMI/EMC failures occur at the weakest point in a product's design—in this case, where a signal (and interference) enters or leaves a shielded and filtered structure. Within the audio/video interface, these are the cables that connect devices and act as an antenna. Specifically, the cabling that attaches the display and speakers to a PC are particularly vulnerable and frequently cause EMI/EMC problems. Although we might expect this with video because of the large bandwidth involved, audio is of low frequency and would seem to be benign. This was the case when all audio amplifiers were Class A. However, the high-efficiency Class D amplifiers<sup>2</sup> used today have high-frequency switching signals and can have EMI problems if they are not filtered and shielded properly.

In the past, using large external filters and/or shielded cables were the accepted ways to address these problems. These methods added cost, adversely affected performance, and increased product size. As these products have gotten smaller and evolved into today's audio/video players, EMI/EMC solutions have had to decrease in size while maintaining or even improving performance. To achieve this, small devices like the MAX9511 graphics video interface and MAX9705 Class D audio amplifier have been developed to deliver excellent EMI performance. To show how this was done, we will look at the audio and display interfaces<sup>3</sup> of a typical PC and the EMI performance attainable with these devices despite their diminutive size. However, first we need to understand the different EMI problems that must be solved for an audio/video interface design and the methods available to solve them.

## Video and EMI

All computers use a form of video, referred to as "graphics," that is different from that for a TV.<sup>4</sup> Computer video has red, green, and blue (R, G, B) analog video signals and separate logic signals consisting of horizontal and vertical sync and DDC,<sup>5</sup> all of which have fast rise/fall times. The video connector is typically a high-density, D-subminiature type that connects the display to a PC (**Figure 1**). Although this incorporates shielding (coax) of the video signals and a common-mode choke (CMC) to reduce radiated and conducted EMI, additional filtering is needed to ensure that the EMI requirements are met. In broadcast video applications, similar filtering is used to remove aliasing artifacts from the video in a TV. However, this is not done in graphics video, where instead the goal is to reproduce a checkerboard pattern of "on" and "off" pixels at the highest resolution possible. So, for the best display performance, we want as large a bandwidth as possible. However, in reality, EMI and video performance are traded off and video bandwidth suffers for it. This tradeoff happens for several reasons unique to multisignal video interfaces.

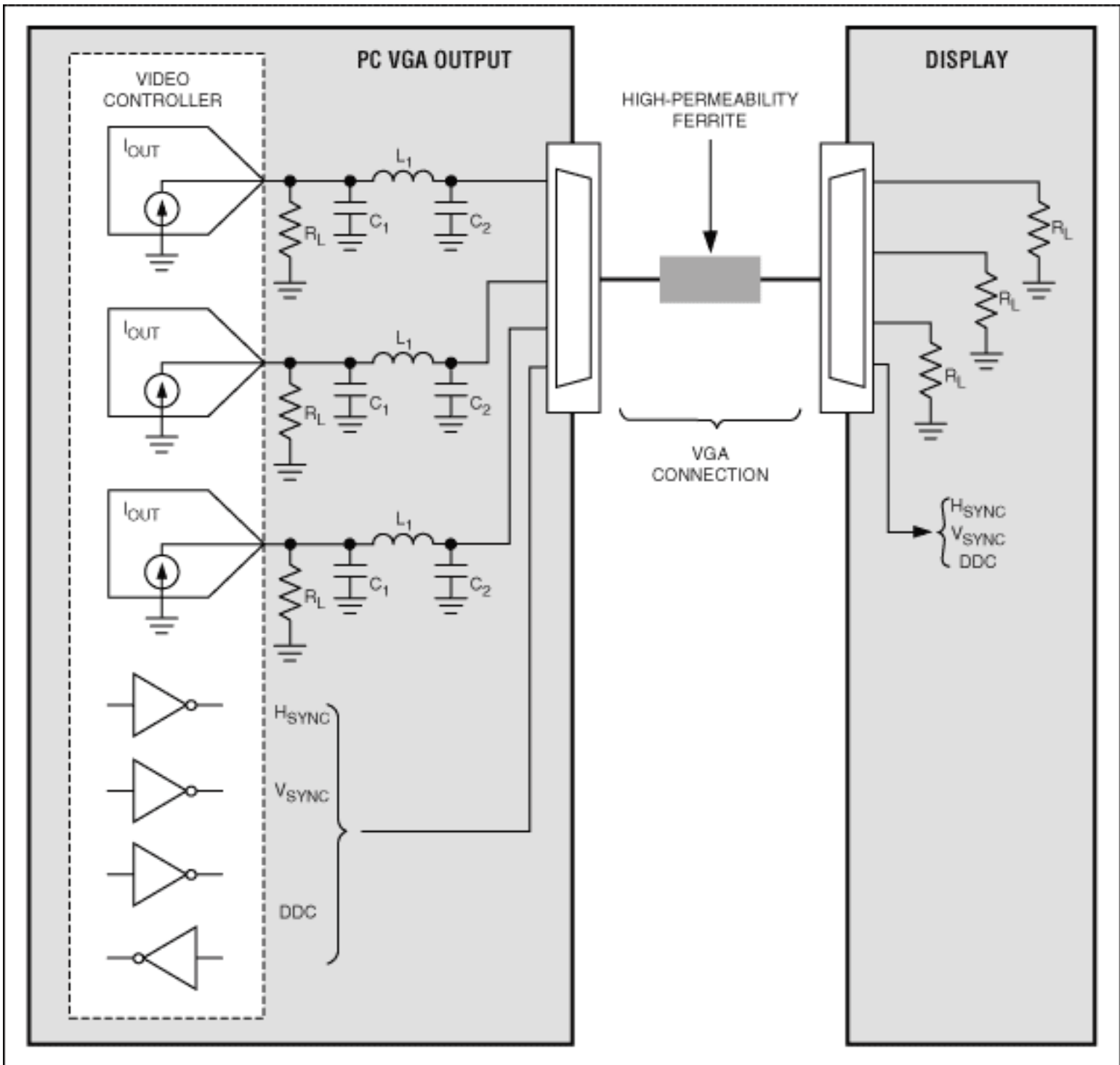

Figure 1. A typical VGA connection is shown with video signals that cause radiated EMI.

For example, when you filter video signals, you introduce a time delay that causes problems like "fringing" at the edge of an image if the individual video channels (R, G, and B) are not closely matched in their timing. To avoid this, the group-delay and group-delay-matching channels<sup>6</sup> must be closely controlled. RGB video is particularly susceptible to both of these parameters.<sup>7</sup> For best performance, the group delay must be constant with frequency, and a minimum group-delay matching of  $\pm 0.5$  pixel time must be maintained between the channels. Assuming they are matched this closely, the sync signals must also track the channel delay to correctly frame the image. If this is done, we then need to address the issue regarding the multiple video resolutions of which a PC is capable.

Optimizing performance is very difficult with a fixed-frequency filter in this application. If we design a filter to suppress EMI from the lowest resolution, the filter's stopband may intrude into the signal bandwidth of higher resolution formats, thus compromising their performance. Design for the highest resolution and you may not meet the EMI requirements. Clearly the best solution is a "tunable" filter with a frequency response that tracks

the display resolution being used, but this approach increases cost and possibly size. Secondary, but still important to EMI performance, are the fast rise/fall times of the sync and DDC drivers. A designer must include a way to filter these rise/fall times in any complete EMI solution. There are also legacy issues like video DAC load detection to satisfy plug-and-play requirements.

The MAX9511<sup>8</sup> performs all of these functions. **Figure 2** shows typical before and after performance of a high-resolution graphics board output with a MAX9511 compared to an L-C filter and the raw output.

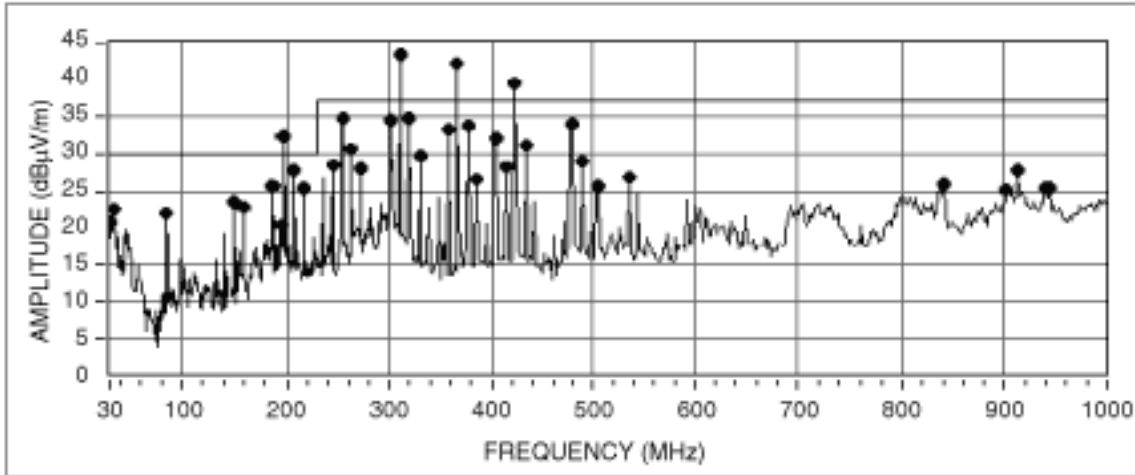

(a)

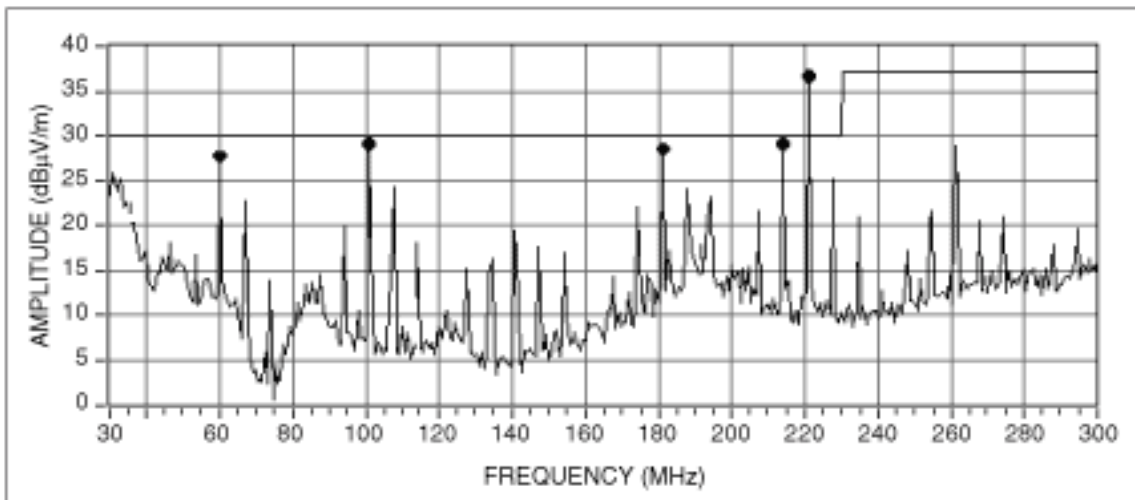

(b)

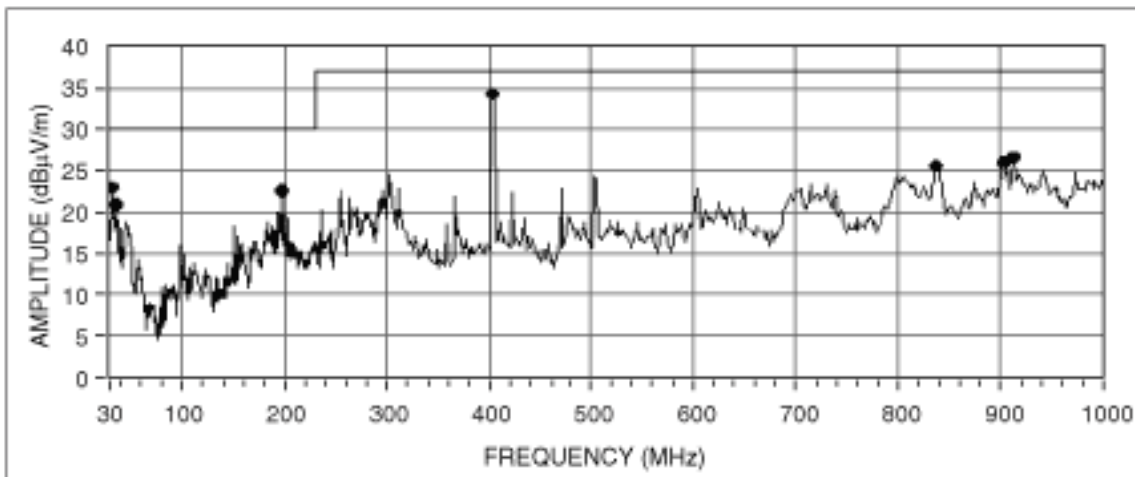

(c)

Figure 2. Radiated EMI is shown a) without filtering, b) with a passive LC filter, and c) with the MAX9511.

## Complete EMI Solution (MAX9511)

The MAX9511 graphics video interface shown in **Figure 3** provides a matched, triple-channel, tunable EMI filter for the RGB video over the range of VGA to UXGA resolutions with channel-to-channel skew error of < 0.5ns. Tuning is accomplished by changing a single resistor ( $R_x$ ). **Table 1** shows the resistor value vs. the slew rate for different VESA resolutions and their sampling clock range. In the **Figure 4** example, the MAX54329 I<sup>2</sup>C±-controlled potentiometer provides 32 individual steps of filter control. However, as can be seen in Table 1, only three or four levels are required in most applications. This allows the modification of a product's EMI profile without making any mechanical or electrical changes during final EMI/EMC testing.

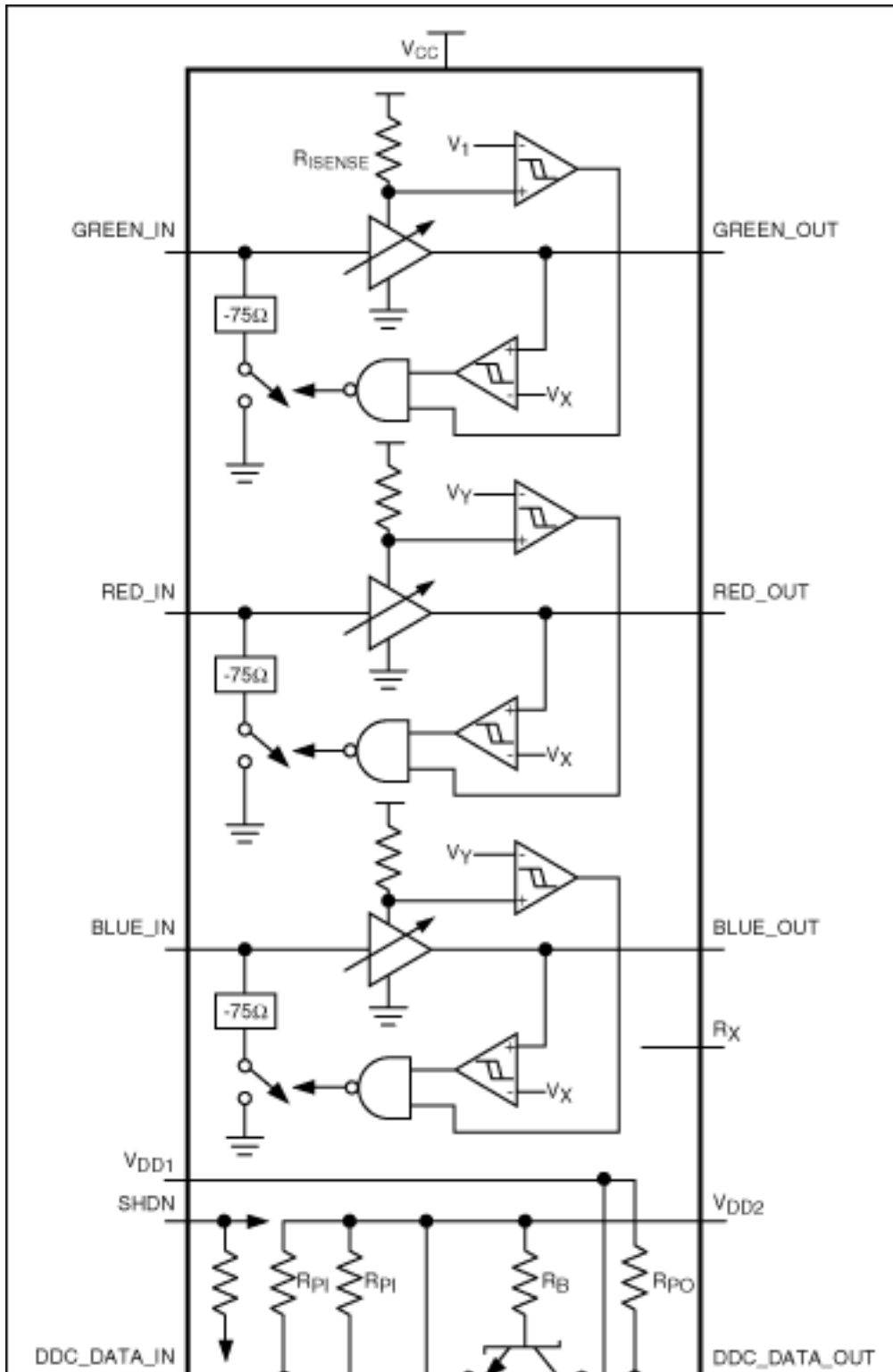

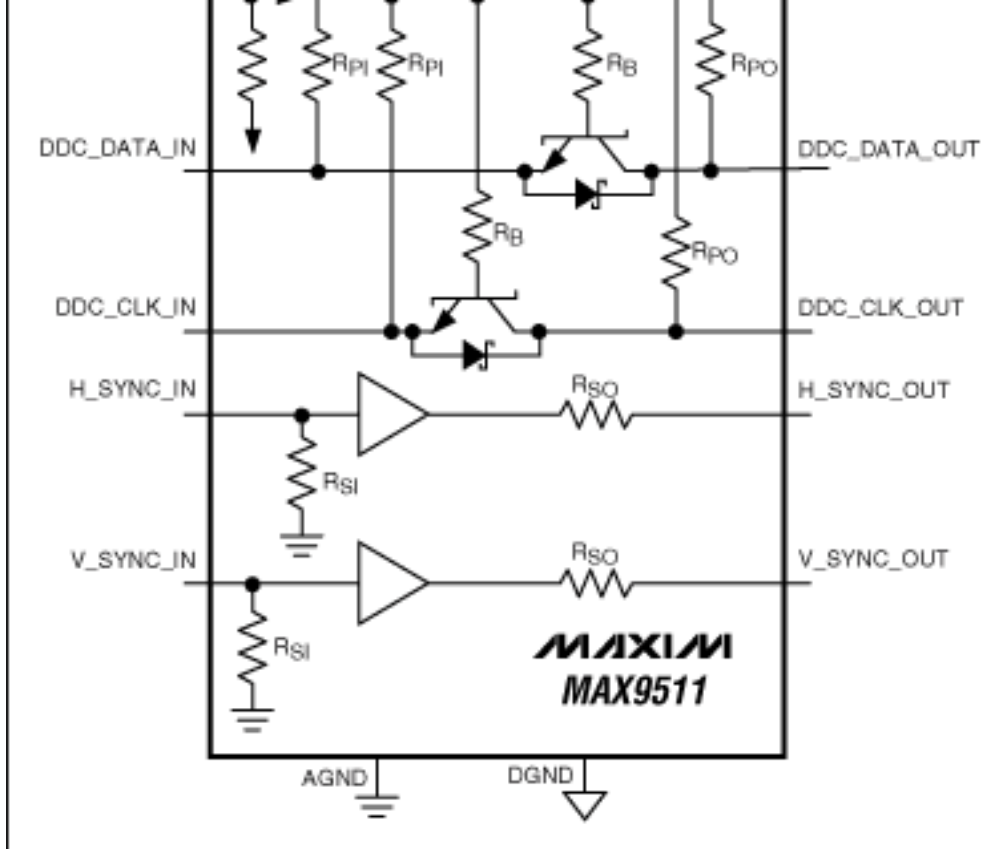

Figure 3. The MAX9511 VGA interface has EMI suppression.

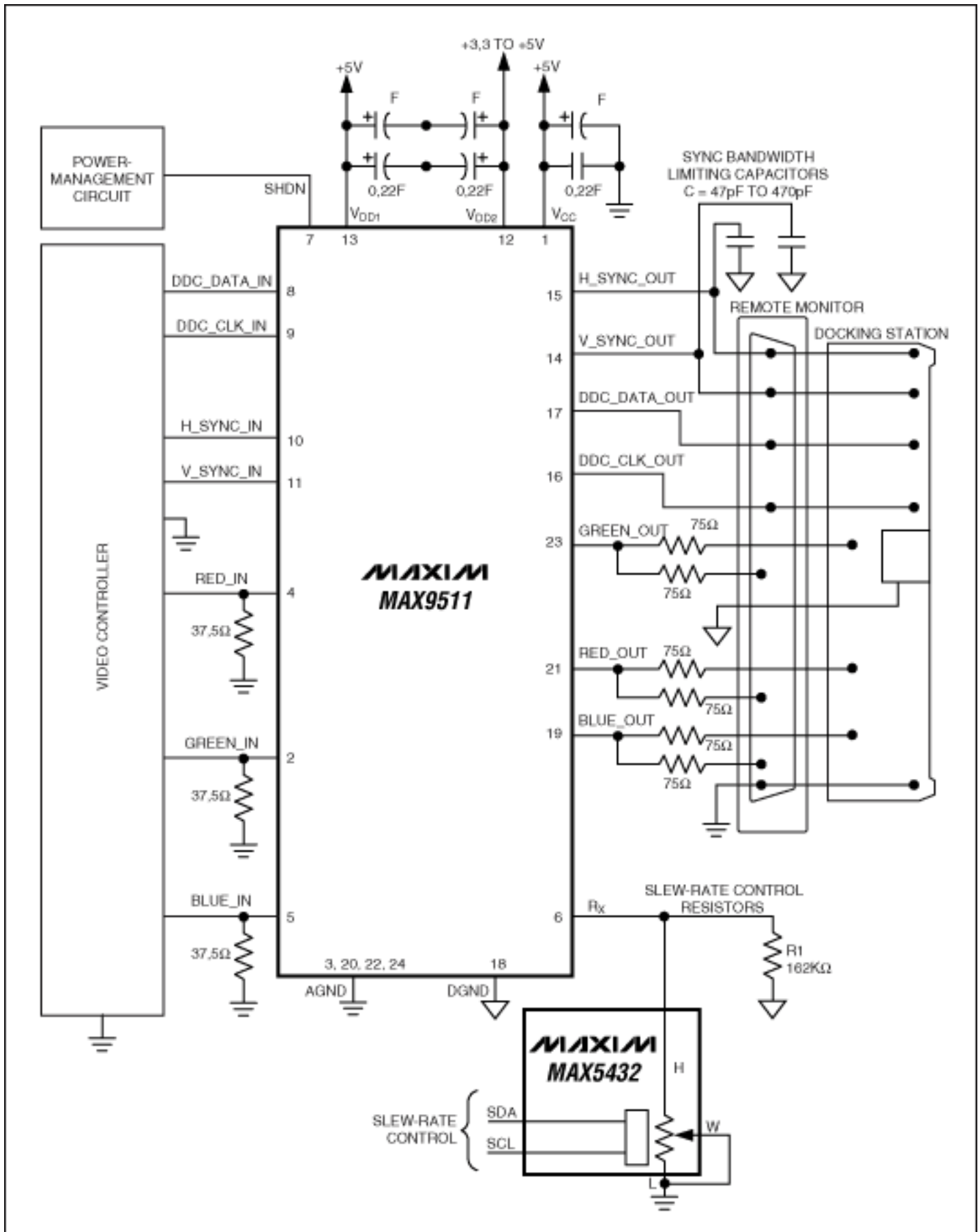

Figure 4. The MAX9511 drives multiple outputs. Adjustable filtering is controlled by the MAX5432 I<sup>2</sup>C-adjustable digital potentiometer.

**Table 1. Slew Rate, Bandwidth, and Rx Value for the MAX9511**

$R_x$ (k $\Omega$ )	MAX9511 Slew Rate vs. $R_x$		
	Slew Rate (V/ms)	Pixel Clock Frequency (MHz)	VESA Resolution
7	1408	160 to 230	UXGA (1600 x 1200)
10	1255	160 to 230	UXGA (1600 x 1200)
12	1050	100 to 150	SXGA (1280 x 1024)
15	810	100 to 150	SXGA (1280 x 1024)
20	613	45 to 95	XGA (1024 x 768)
25	470	45 to 95	XGA (1024 x 768)
30	368	45 to 95	XGA (1024 x 768)
35	298	35 to 50	XGA (1024 x 768)
40	255	35 to 50	SVGA (800 x 600)
45	203	35 to 50	SVGA (800 x 600)
50	158	25 to 30	VGA (640 x 480)
> 50	< 150	< 25	QCIF

The RGB video outputs are of low impedance ( $Z_{OUT} < 1\Omega$ ) and, with the 75 $\Omega$  back terminations, provide 45dB to 50dB of isolation between the remote monitor and docking station. Previously, driving two different outputs this way required a switch to avoid having a long, unterminated stub attached to the L-C filters' output. Figure 4 shows how the output load is detected and reflected to the input as an apparent change in the DAC termination impedance. The video controller driving the RGB inputs can sense this and, if no load is present, shut off the video and sync outputs through the shutdown pin. The DDC is always on to support plug-and-play applications, and the drivers feature voltage-level translation to convert low-voltage controller levels to standard 5V interface levels. The sync drivers have 50 $\Omega$  (typ) of output impedance that can be configured to filter the edges with a single external capacitor (Figure 4). The sync jitter (without any capacitors) is typically less than 0.5ns. Video performance includes +6dB of gain with a SNR of 50dB, a linearity error of 0.036%, and < 1% overshoot/undershoot with a well-damped response.

## Audio and EMI

Audio has a different set of problems for achieving efficiency and performance without causing EMI. In portable applications, we want to maximize battery life and we do not want heat caused by an inefficient design, so Class D audio amplifiers are widely used. The problem with Class D amplifiers is that they use PWM to attain high efficiency, much like a switching power supply. Attaching unshielded speaker wires to the output causes them to act as an antenna and radiate EMI. Although the clock frequency is above the audio spectrum, typically 300kHz to 1MHz, it is a square wave with sizeable harmonic content. A filter that can remove this harmonic content is large and expensive. In portable applications like laptops, this is not an option due to size alone.<sup>10</sup>

The typical design topology does not help either. To maximize the output audio power, portable applications use an output connection referred to as a bridge-tied load (BTL) in which both speaker wires are actively driven (**Figure 5**). With Class D, a comparator monitors the analog input voltage and compares it to a triangular clock waveform. The comparator trips when the input magnitude of the triangular waveform exceeds the audio input voltage, and an inverter generates the complementary PWM waveform to drive the other side of the BTL output stage. Because of this BTL topology, the output filter actually requires twice as many parts as a single-ended audio output: two inductors (L1 and L2) and two capacitors (C1 and C2). Because the inductors need to handle the peak output current, they are large and take most of the space.

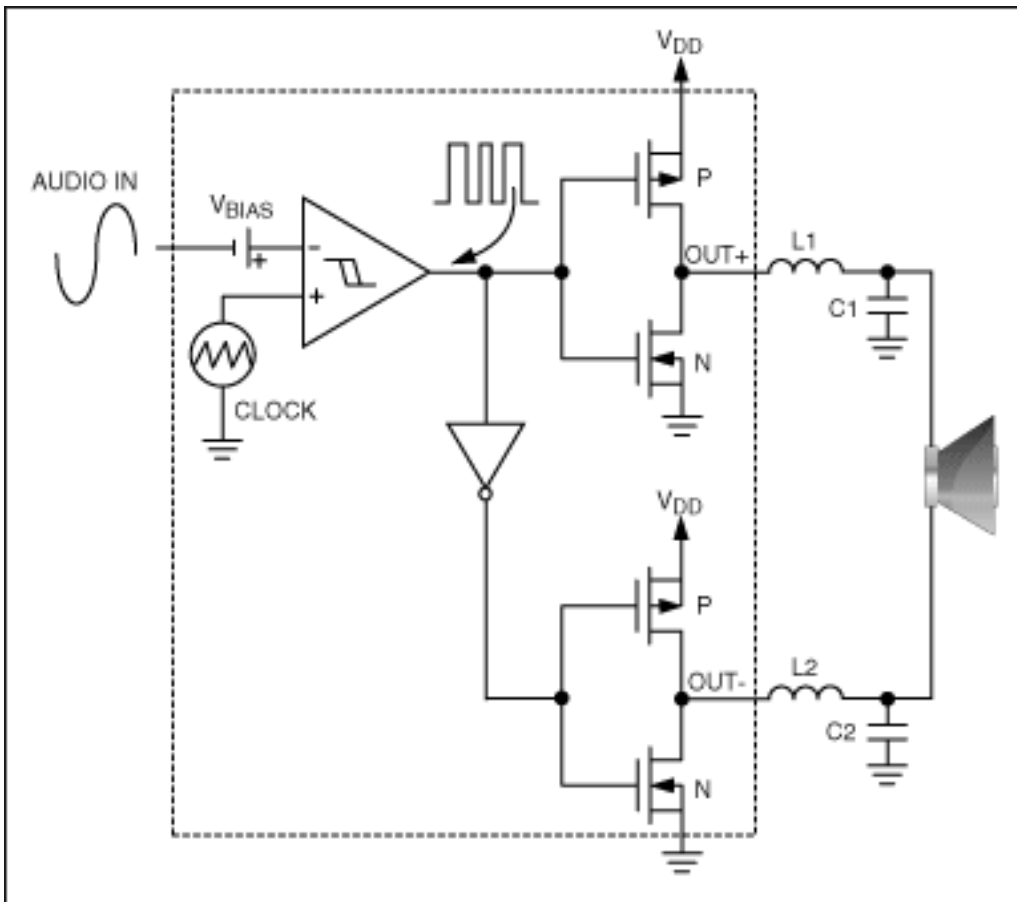

Figure 5. The active emissions limiting technique is shown in a typical Maxim Class D audio amplifier.

Class D amplifiers can be made to appear to run without filters by using the speaker voice-coil inductance and discrete capacitors to implement a filter. However, you are limited to internal speakers as the wires still radiate a considerable amount of energy. An alternative is to modify the switching process so the amplifier remains highly efficient, but exhibits less EMI and therefore requires a smaller filter. One way to do this is to modulate the frequency of the clock to reduce the energy on a per-hertz basis.<sup>11</sup> This is called spread-spectrum modulation,<sup>12</sup> or dithering of the clock frequency. However, the spectrum can be spread only so far before the returns begin to diminish. **Figure 6** shows the effect of this technique on a typical emissions profile.

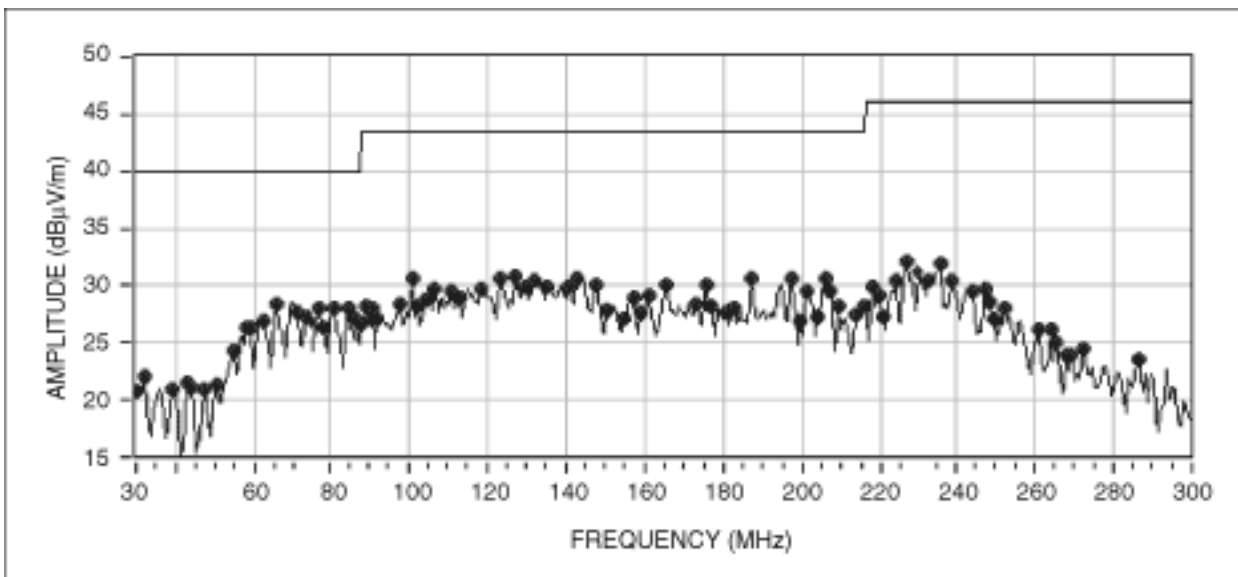

Figure 6. The MAX9705 radiated emissions data, obtained using a MAX9705EVKIT (12-inch, unshielded twisted pair), shows the effect of spread-spectrum modulation.

In parts with spread-spectrum modulation alone, speaker wires longer than a few inches radiate too much energy above a few hundred milliwatts of output power. Increasing the clock frequency does not help because, as the

frequency increases, the Class D amplifiers' output spectra drop off. However, the speaker wires become more efficient as antennas, effectively canceling any improvement in performance. To further improve the EMI requires modifying the PWM waveforms used in the Class D amplifier itself. This is done using an application-specific method called active emissions limiting.

Active emissions limiting circuitry sets the minimum pulse width in the amplifier, which is not bounded in designs like that of Figure 5. Together with control of the overlap, rise/fall time, and clock frequency, this bounds the power spectra that the process causes<sup>13</sup> for a given output power level. The objective is to reduce the spectra to a level where the part can operate without any external filtering with up to 24in of external speaker wire and still meet the radiated emissions limits.

We also want audio performance, and to do that we need > 2W peak power out. At the same time, we want to minimize heat and maximize battery life. Therefore, we want high efficiency while operating from a low-voltage single supply and a low-power shutdown mode for headphone use. The THD+N must be low, the SNR should be high with click-and-pop suppression, and the input must be compatible with either single-ended or differential inputs. The MAX9705 can accomplish these tasks and more, as we shall see next.

## Active Emissions Limiting (MAX9705)

The technique used for active emissions limiting in Maxim's Class D amplifiers is shown schematically in **Figure 7**. What is not obvious from this figure is how the switching is done. By carefully tailoring the drive and using zero dead-time control, the efficiency of the MAX9705 Class D amplifier is > 85%. The unique, patented spread-spectrum modulation mode flattens the spectral components, reducing the EMI emissions radiated by the cable and speaker. For stereo or multichannel operation, a sync input locks the amplifiers to a common clock range of 800kHz to 2MHz to minimize intermodulation products that would otherwise occur with multiple free-running sources. The combination of these two unique technologies, spread-spectrum modulation and active emissions limiting, allows Maxim's Class D audio amplifiers to run "filterless" with up to 24in of unshielded speaker wire before exceeding the EMI limits of FCC Part 15 (**Figure 8**).

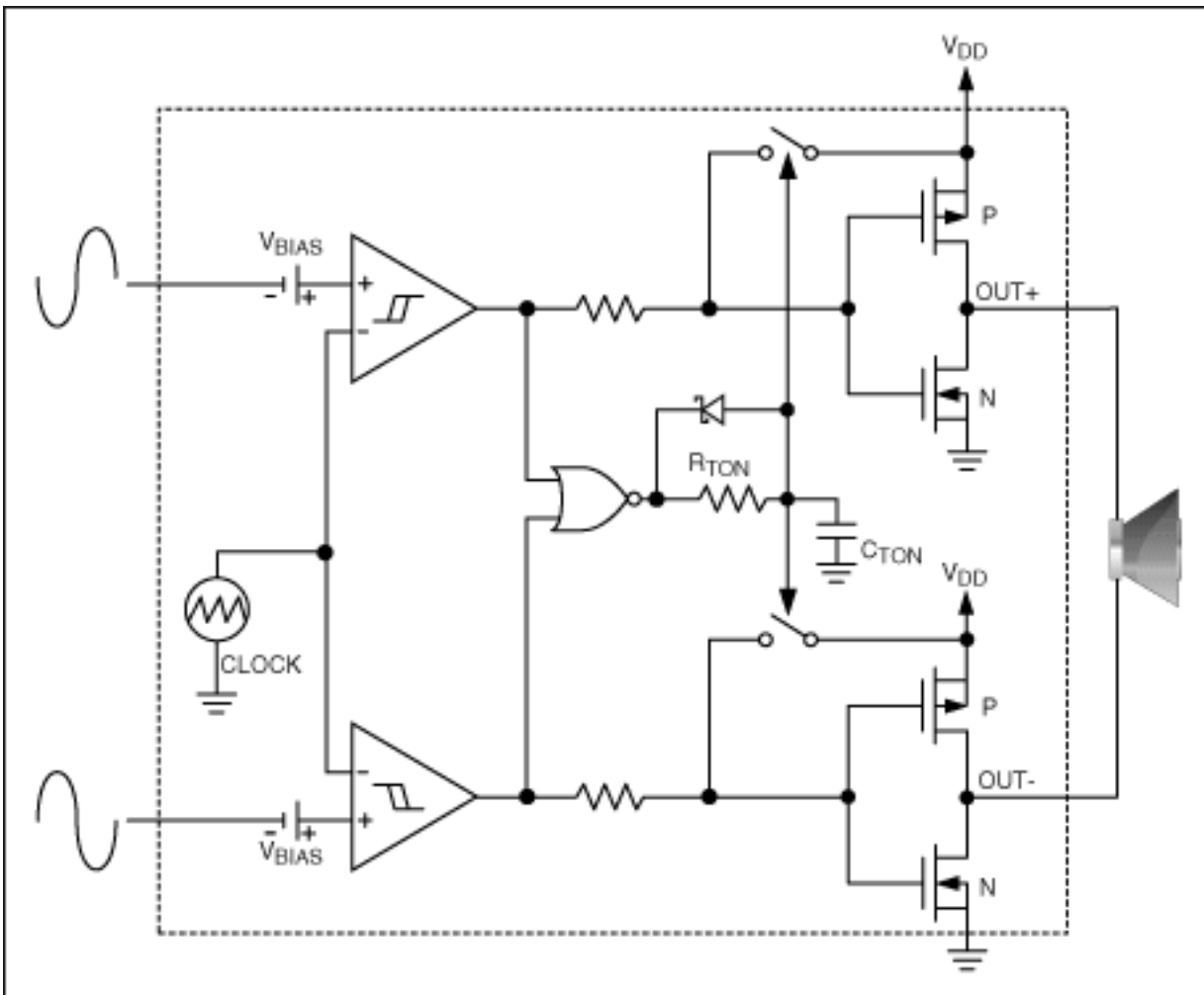

Figure 7. The MAX9705 Class D amplifier has an internally generated sawtooth with a differential input. If a single-ended input is used, a differential input is derived internally.

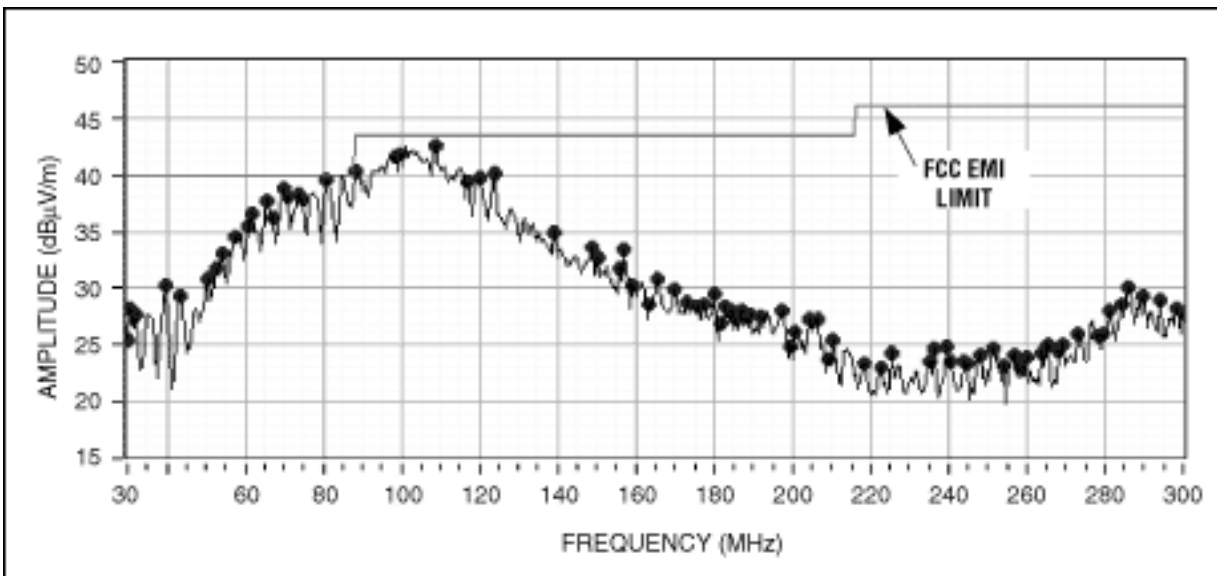

Figure 8. The MAX9705 radiated emissions data is shown for a 24in, unshielded twisted pair in spread-spectrum modulation mode.

Besides EMI, the audio performance is excellent with a THD+N of 0.02% at 1W, increasing to 1% at 2.3W, and an SNR of 90dB. The input can be differential or single ended with a fixed gain of +6dB, +12dB, +15.6dB, or +20dB available to address any application (Figure 7). A shutdown minimizes power. Also, a sync input allows the MAX9705 to provide monaural, stereo, or multichannel high-performance audio and still meet EMI radiation requirements with external speakers, but without filters.

## Conclusion

The MAX9511 and the MAX9705 represent a modern approach to EMI/EMC control. They actively reduce EMI in the products in which they are used. Instead of relying on large external filters and shields with inherent increases in cost and size, as done in the past, they use state-of-the-art technology to virtually guarantee electromagnetic compatibility and performance.

## References

1. FCC Part 15 in the US, VCCI in Japan, and EN55000 in Europe all require EMI/EMC compliance.
2. [Application note 1760: "Class D Audio Amplifiers Save Battery Life"](#)
3. "EMI and Emissions," Gerke and Kimmel Associates.
4. [Application note 1184: "Understanding Analog Video Signals"](#)
5. VESA Standard VSIS, v. 1, rev. 2, 12/12/2002.
6. "Design of Analog Filters," Schaumann and Van Valkenburg, Oxford University Press.
7. "Flat Panel Displays and CRT," L.E. Tannas, editor, Van Nostrand.
8. MAX9511 data sheet
9. [MAX5432 data sheet](#)
10. [Application note 1760: "Class D Audio Amplifiers Save Battery Life"](#)
11. [Application note 3503: "Clock Generation with Spread Spectrum"](#)
12. "Spread Spectrum Systems," R.C. Dixon., J. Wiley & Sons, 1976.
13. "High-Speed Digital Design," Graham and Johnson, Prentiss Hall, 1993.

---

Application Note 3882: [www.maxim-ic.com/an3882](http://www.maxim-ic.com/an3882)

## More Information

For technical support: [www.maxim-ic.com/support](http://www.maxim-ic.com/support)

For samples: [www.maxim-ic.com/samples](http://www.maxim-ic.com/samples)

Other questions and comments: [www.maxim-ic.com/contact](http://www.maxim-ic.com/contact)

## Automatic Updates

Would you like to be automatically notified when new application notes are published in your areas of interest?

[Sign up for EE-Mail™.](#)

## Related Parts

MAX9511: [QuickView](#) -- [Full \(PDF\) Data Sheet](#) -- [Free Samples](#)

MAX9705: [QuickView](#) -- [Full \(PDF\) Data Sheet](#) -- [Free Samples](#)

AN3882, AN 3882, APP3882, Appnote3882, Appnote 3882

Copyright © by Maxim Integrated Products

Additional legal notices: [www.maxim-ic.com/legal](http://www.maxim-ic.com/legal)