

APPLICATION NOTE 3881

## Spread-Spectrum-Modulation Mode Minimizes Electromagnetic Interference in Class D Amplifiers

*This application note examines two different technologies for Class D (switch mode) amplifiers: pulse-width modulation (PWM) and spread-spectrum modulation. Conventionally, PWM Class D amplifiers require costly, bulky filtering components to reduce the electromagnetic interference (EMI) generated by its near rail-to-rail swings and fast-switching frequency. Now, however, spread-spectrum-modulation technology for Class D amplifiers enables designers to eliminate these filtering components without degrading audio performance or amplifier efficiency.*

### Introduction

Class D amplifiers are attractive to designers of portable audio applications because they offer better efficiency than Class AB amplifiers. Some designers, however, have been prevented from utilizing Class D amplifiers in their portable applications because of the large, costly filtering components conventional PWM Class D amplifiers require to reduce electromagnetic interference. Maxim's spread-spectrum-modulation technology for Class D amplifiers enables designers to eliminate these filtering components without compromising audio performance or amplifier efficiency—thereby, easing the adoption of highly efficient Class D amplifiers in portable audio applications.

### Conventional Pulse-Width-Modulation Amplifier Topology

Figure 1 illustrates the topology of a typical PWM, bridge-tied-load (BTL) Class D amplifier. A typical PWM scheme utilizes an internally generated sawtooth waveform as a reference to its input stage. A comparator monitors the analog input voltage and compares it to the sawtooth waveform. The comparator output goes low when the input magnitude of the sawtooth waveform exceeds the input voltage. An inverter is utilized at the output of the comparator to generate a complementary PWM waveform for the second leg of the BTL output.

A PWM amplifier usually requires bulky filtering components at its output because its near rail-to-rail swings and fast-switching frequency can lead to high radio-frequency (RF) emissions and interference. An LC filter is typically required to reduce this high-frequency interference and extract audio content from the duty cycle of the PWM signal.

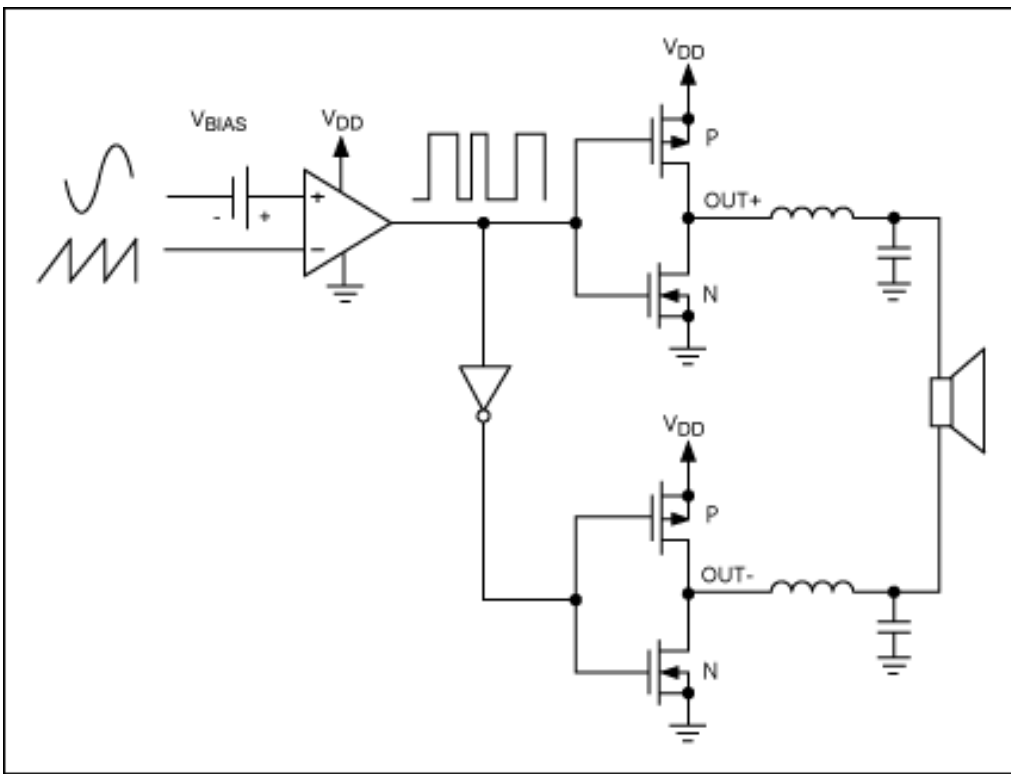

Figure 1. Conventional Pulse-Width-Modulation Topology.

## Spread-Spectrum-Modulation Amplifier Topology

An alternative to employing costly large-output LC filters is to modify the switching process so that the amplifier remains highly efficient and exhibits less EMI. Maxim's Class D amplifiers accomplish precisely this goal. They feature a unique, patented, spread-spectrum-modulation mode that flattens wideband spectral components, minimizing EMI emissions from the speaker and cables. **Figure 2** uses the [MAX9700](#) to illustrate the topology of Maxim's Class D amplifiers.

The modulation scheme of Maxim's Class D amplifiers utilizes an internally generated sawtooth waveform and a complementary signal pair at its input stage. If a *complementary* input signal is not available, a differential input is derived internal to the IC.

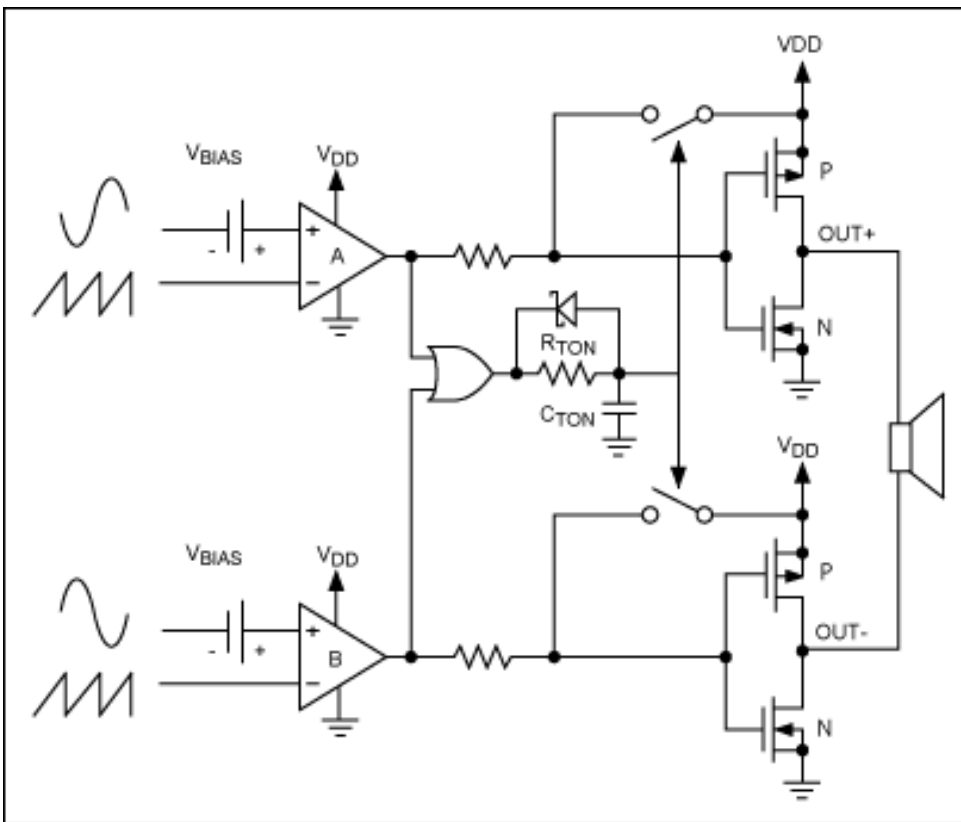

Figure 2. Mono Class D Amplifier Topology.

Comparators monitor the Class D input and compare the complementary input voltages to a sawtooth waveform. Comparator A outputs a zero-volts signal when the magnitude of the sawtooth waveform exceeds the input voltage—pulling the corresponding Class D output (OUT+) high to  $V_{DD}$ . Comparator B provides a zero-volts potential at its output when the sawtooth waveform exceeds its input voltage—similarly pulling the corresponding Class D output (OUT-) high to  $V_{DD}$ . After both Class D outputs are pulled high, a timer begins at the output of a simple NOR gate with a time-constant  $\tau$ , equal to  $1 / (R_{TON} * C_{TON})$ . At a fixed time ( $\tau$ ), both Class D outputs are pulled to GND and each comparator is reset. This sequence generates a minimum-width pulse  $t_{ON(MIN)}$  at the output of the second comparator. As the input voltage increases or decreases, the duration of the pulse at one output (the first comparator to trip) increases, while the other output-pulse duration remains at  $t_{ON(MIN)}$ . This causes the net voltage across the speaker ( $V_{OUT+} - V_{OUT-}$ ) to change.

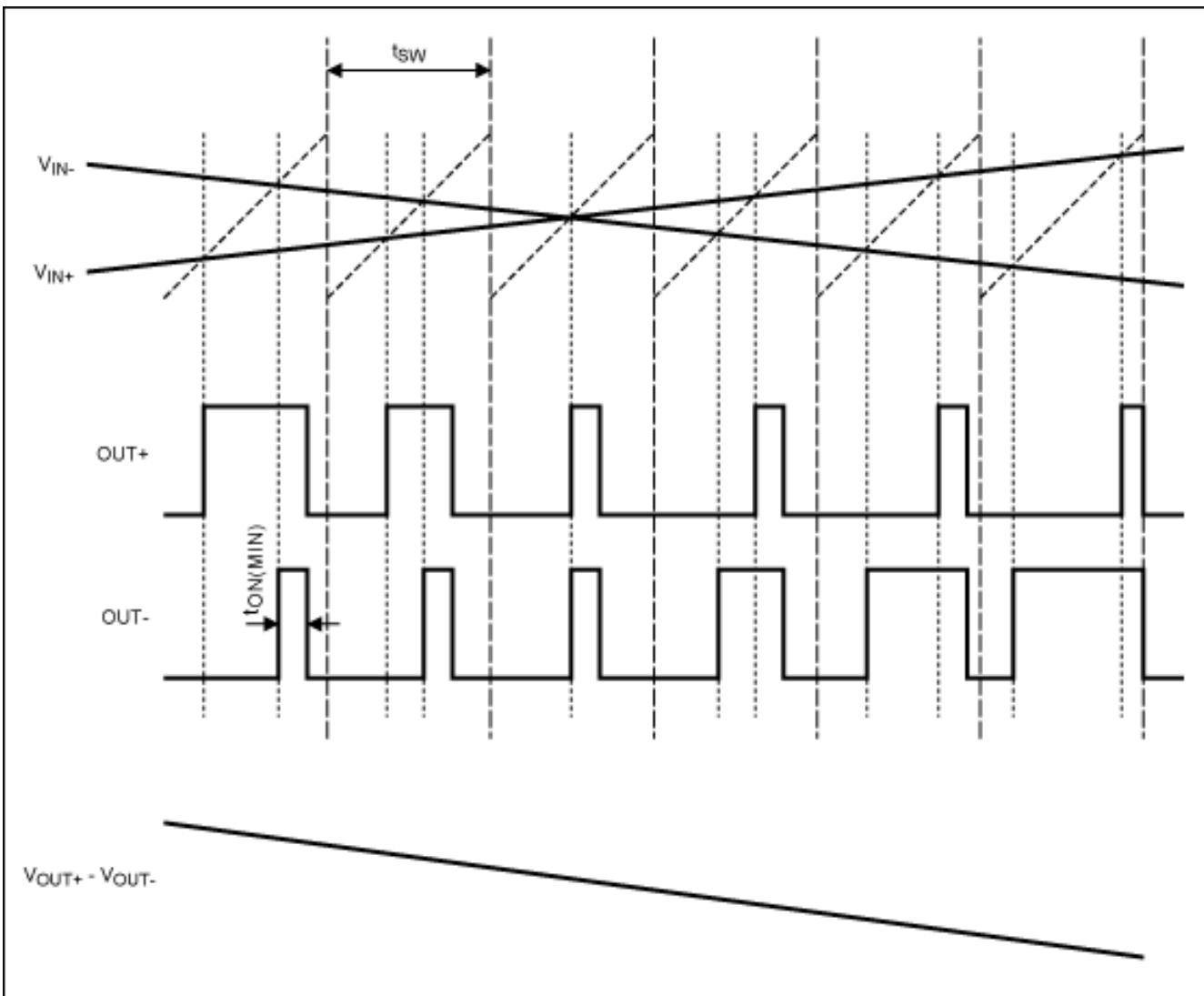

Figure 3. Maxim Class D BTL Output with Input Signal Applied, FFM Mode.

## Fixed-Frequency Modulation vs. Spread-Spectrum Modulation

Maxim's Class D technology employs two modulation modes: (1) fixed-frequency-modulation (FFM) mode and (2) spread-spectrum-modulation mode. In FFM mode (**Figure 3**), the period of the sawtooth waveform remains constant—as it does in conventional PWM technology. In spread-spectrum-modulation mode (**Figure 4**), the period of the sawtooth waveform changes (typically  $\pm 10\%$ ) from cycle to cycle. The period variation of the sawtooth waveform is exaggerated in Figure 4 to illustrate the effect.

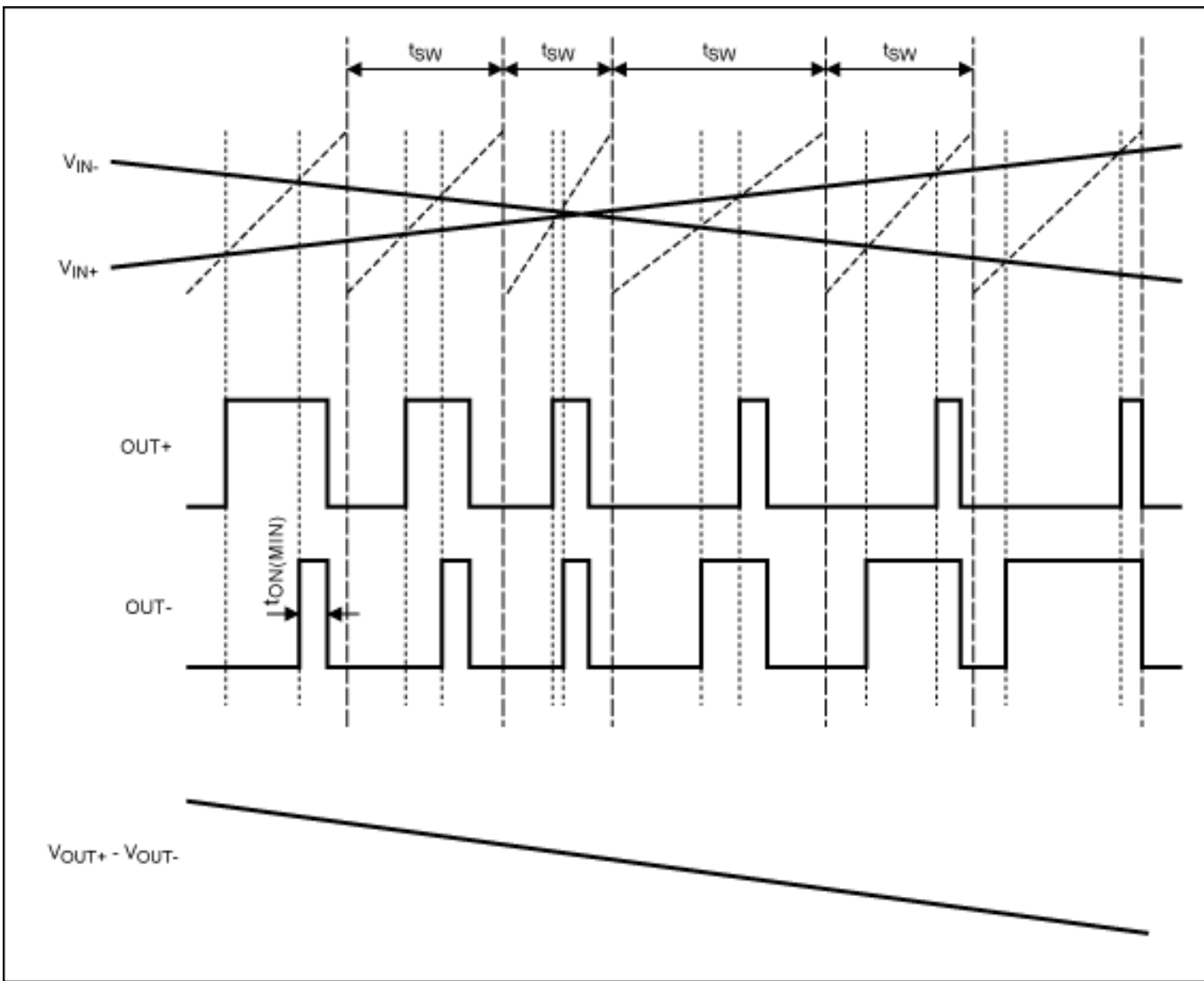

Figure 4. Maxim Class D BTL Output with Input Signal Applied, Spread-Spectrum-Modulation Mode.

The cycle-to-cycle variation of spread-spectrum-modulation mode allows for a reduction in energy at the fundamental frequency ( $f_0 \pm 10\%$ ) with a similar spreading of the harmonic components over a specified bandwidth ( $nf_0 \pm 10\%$ , where  $n$  is a positive integer). Instead of a large amount of spectral energy present at multiples of the switching frequency, the energy is now spread over a bandwidth that increases with frequency. Above a few megahertz, the wideband spectrum looks like white noise for EMI purposes. In FFM mode, energy is contained in narrow bands with high peaks (**Figure 5a**). In spread-spectrum-modulation mode, energy is contained in wider bands while the peak energy is reduced (**Figure 5b**). Note that the third harmonic is almost lost in the noise floor in Figure 5b.

## Fixed-Frequency-Modulation

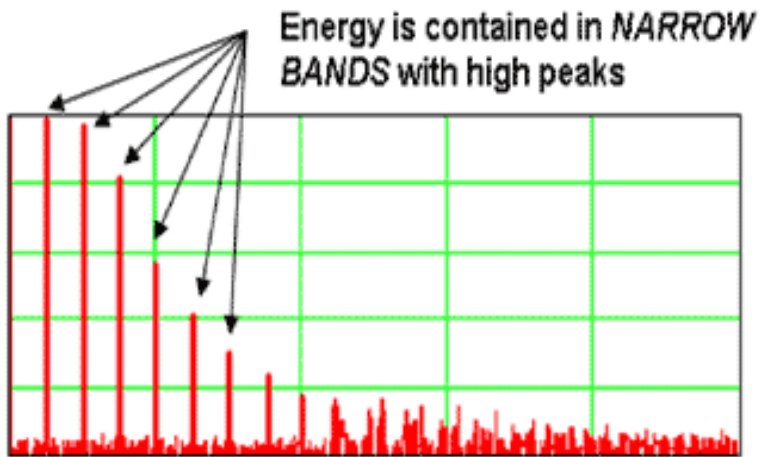

Figure 5a. Maxim's FFM Mode.

## Spread-Spectrum-Modulation

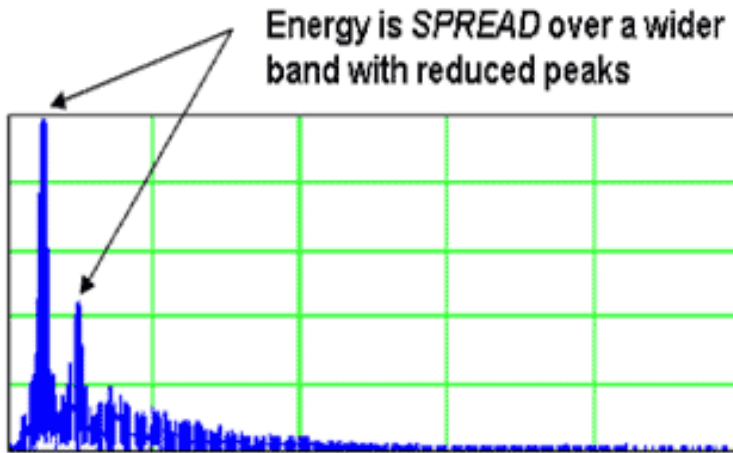

Figure 5b. Maxim's Spread-Spectrum-Modulation Mode.

## Spread-Spectrum Modulation Minimizes EMI Emissions

Maxim's spread-spectrum technology allows for the truly "filterless" operation of Class D amplifiers, provided that the speaker cables are not too long. Large-output LC filters are typically required for traditional PWM architectures to ensure that the consumer product containing the Class D amplifier can pass EMI regulations. Maxim's proprietary spread-spectrum technology reduces radiated emissions in Class D amplifiers, enabling them to meet EMI regulations with zero or minimal output filtering (see **Appendix**).

EMI regulations require an end product to pass established quasi-peak detection limits—such as those established by the CE (Communaute Europeene, the European Standard) and FCC (Federal Communications Commission, the U.S. Standard)—to ensure electromagnetic disturbances are kept at a minimum. These regulatory agencies define electromagnetic interference as any electromagnetic disturbance that interrupts, obstructs, or degrades the effective performance of electronics and/or electrical equipment. Quasi-peak detection requires a measured signal level to be weighted by the repetition frequency of the signal's spectral components. The lower the repetition frequency, the lower the quasi-peak reading will be.<sup>1</sup>

Spread-spectrum modulation makes use of the "averaging" nature of quasi-peak detection and reduces EMI measurements considerably (**Table 1**). In spread-spectrum-modulation mode, the peak fundamental frequency of a Class D amplifier is randomized over a bandwidth—usually  $\pm 10\%$  of its fundamental switching frequency. Given that quasi-peak detection is implemented using a 120kHz resolution bandwidth in the analyzer, excepting the fundamental switching frequency and the first few harmonics, the switching energy will be present only part of the time at any single center frequency.

**Table 1. MAX9759 Radiated-Emissions Data (MAX9759EVMKit, Spread-Spectrum-Modulation Mode, 3" Twisted-Pair Speaker Cable, "Filterless")**

Peak (Pk) Readings					Quasi-Peak (QP) Readings					QP Reduction from Peak
Frequency	Level	FCC Class B		Detector	Frequency	Level	FCC Class B		Detector	Pk - QP
MHz	dB $\mu$ V/m	Limit	Margin	Pk/QP/Ave	MHz	dB $\mu$ V/m	Limit	Margin	Pk/QP/Ave	dB
143.411	35.8	43.5	-7.7	Pk	143.411	32.5	43.5	-11.0	QP	3.3
177.265	37.1	43.5	-6.4	Pk	177.265	33.5	43.5	-10.0	QP	3.6
193.758	36.4	43.5	-7.1	Pk	193.758	32.8	43.5	-10.7	QP	3.6
155.990	37.0	43.5	-6.5	Pk	155.990	33.7	43.5	-9.8	QP	3.3
168.027	37.2	43.5	-6.3	Pk	168.027	33.8	43.5	-9.7	QP	3.4
186.025	37.0	43.5	-6.6	Pk	186.025	33.2	43.5	-10.3	QP	3.7
160.267	36.8	43.5	-6.7	Pk	160.267	32.8	43.5	-10.8	QP	4.1

## Conclusion

A Class D amplifier's near rail-to-rail swings and fast switching frequency can lead to high RF emissions and interference. A bulky, costly LC filter is typically utilized to reduce this high frequency interference before audio content is reproduced at the transducer. However, Maxim's spread-spectrum-modulation techniques enable the truly 'filterless' operation of lower power implementations in which effective PC-board (PCB) layout and relatively short speaker cable runs are employed.

<sup>1</sup>For further quasi-peak detection details, see Reference Publication 16 of the International Special Committee on Radio Interference (CISPR) of the International Electrotechnical Commission.

## Appendix

### An Overview of Filter Topologies

There are three types of filter topologies for Class D power amplifiers: (1) FB-C, ferrite bead and capacitor; (2) LC, inductor and capacitor; and (3) "Filterless." The type of filtering selected for a particular design is dependent on the application's speaker cable length and PCB layout. The advantages and disadvantages of these three filter topologies are outlined below.

#### FB-C Filtering

In applications with moderate speaker-cable runs, FB-C filtering provides adequate margins to the governing EMI limits. The FB-C filter topology results in a compact, cost-effective solution compared to LC filtering. However, FB-C filtering is not practical in many applications because it only begins to be effective at frequencies above 10MHz. Moreover, poor speaker-cable routing at frequencies less than 10MHz can lead to conductive-emissions failures.

#### LC Filtering

In contrast, LC filtering allows for suppression to begin around 30kHz. This is a 'safe' option for filtering in designs in which long speaker cables are implemented and the PCB layout is not optimized for suppression. LC filtering, however, results in costly, bulky external components that may not be an option for portable applications. Additional components may also be needed to ensure suppression at frequencies > 30MHz, where the main inductors become self-resonant.

#### "Filterless" Filtering

"Filterless" amplifier topology is the most cost-effective solution because it eliminates the need for additional filtering components. Class D amplifiers can pass radiated-emissions standards with short, twisted-pair speaker cable. However, as with FB-C filtering, conductive-emissions failure may be present due to poor speaker-cable routing. Also note, Maxim's Class D amplifiers can be made to run "filterless," if the speaker is inductive at the amplifier's switching frequency. The high inductance at the switching frequency keeps the overcurrent relatively constant while the output voltage is switching.

Application Note 3881: <http://www.maxim-ic.com/an3881>

#### More Information

For technical questions and support: <http://www.maxim-ic.com/support>

For samples: <http://www.maxim-ic.com/samples>

Other questions and comments: <http://www.maxim-ic.com/contact>

AN3881, AN 3881, APP3881, Appnote3881, Appnote 3881  
Copyright © 2007 by Maxim Integrated Products  
Additional legal notices: <http://www.maxim-ic.com/legal>