



APPLICATION NOTE 3878

Reduce EMI from Class-D Amplifiers Using New Modulation Techniques and Filter Architectures

Abstract: Class D amplifiers have always offered better efficiency than Class AB amplifiers for low-power applications. This inherent advantage, however, rarely outweighed the traditional disadvantages of Class D, which were higher cost, reduced audio performance, and the need for output filtering. Recent advances in Class D technology, however, have brought Class D costs and audio performance up to equal Class AB. Some novel Class D output modulation schemes, moreover, now ease the EMI burden in many applications.

Introduction

The state of the art in Class D amplification has progressed rapidly in the past few years, most noticeably for lower power applications that require less than 50W per channel. For these low-power applications, Class D has an inherent efficiency advantage over the traditional Class AB amplifier, because the Class D output stages are always on or off, with no intermediate bias stage necessary. Historically, however, this efficiency advantage never held widespread appeal for designers, because Class D also had notable disadvantages: higher parts cost, poor audio performance (compared to Class AB), and the need for output filtering.

Two major factors have reversed this design trend in recent years, making Class D more appealing in a wide range of applications.

First, there is market need. Two rapidly growing end-equipment markets benefit from Class D amplification in different ways; cell phones and LCD flat-panel displays. With cell phones, both the speakerphone and PTT (Push-to-Talk) modes benefit from Class D's higher efficiency, which provides longer battery life. The growth of LCD flat-panel displays generated a need for 'cool running' electronics, as the display color contrast suffers under elevated operating temperatures. As Class D efficiency means that less power is dissipated in the drive electronics, the LCD flat-panel displays operate cooler and with better looking pictures.

The second factor to affect use of Class D is the technology itself. Driven by market needs, several manufacturers now offer improved Class D technology with costs more equitable and audio performance on a par with Class AB. Some novel Class D output modulation schemes, moreover, now ease the EMI burden in many applications.

Some of the newer Class D designs, although derived from older PWM-style architectures, incorporate sophisticated modulation techniques that achieve filterless operation for lower power systems. Efficiency claims can be verified on the bench, but some designers suspect that products based on these new techniques will be rife with EMC/RFI compatibility problems. In reality, the use of effective PCB layouts and short runs of speaker cable can ensure sufficiently low radiated EMI to pass the applicable FCC or CE standards.

Application Challenges

The physical layout in some applications necessitates long speaker cables, for which RF emissions must be more tightly controlled because the speaker cables act as antennae. In effect, the longer the speaker cable, the lower the frequency at which it acts efficiently as an antenna. Meanwhile, other applications require EMI emissions below that of CE/FCC, perhaps to meet automotive specifications or where interference with other circuitry at lower frequencies must be avoided. With such disparate requirements, these applications were historically difficult to overcome.

A flat-panel TV is an obvious example of the above application dilemma. With speakers typically arrayed at the outer edges of the device, long speaker cables are hard to avoid. If analog video signals are present, simply meeting FCC or CE RF emissions may not be sufficient; (these limits are specified from 30MHz upwards) and suppression of the switching fundamental may be necessary to avoid interference effects with the video signal. If you need to use the traditional LC filters that operate effectively with older PWM amplifiers, you should analyze them to ensure that they are effective in suppressing the high-frequency switching transients produced by the latest amplifiers.

PWM-Based Class D Amplifiers

Traditional Class D amplifiers are usually based on the principle of pulse-width modulation (PWM). Their outputs can be configured either single-ended or as a fully differential bridge-tied load (BTL). **Figure 1** shows the output waveforms typical of a BTL, PWM-based Class D amplifier. The fast switching times and nearly rail-to-rail swings give this type of amplifier very high efficiency. However, the wide-output spectrum implied by those same parameters can lead to high-frequency RF emissions and interference. Consequently this design approach usually includes output filters to suppress the unwanted RF effects.

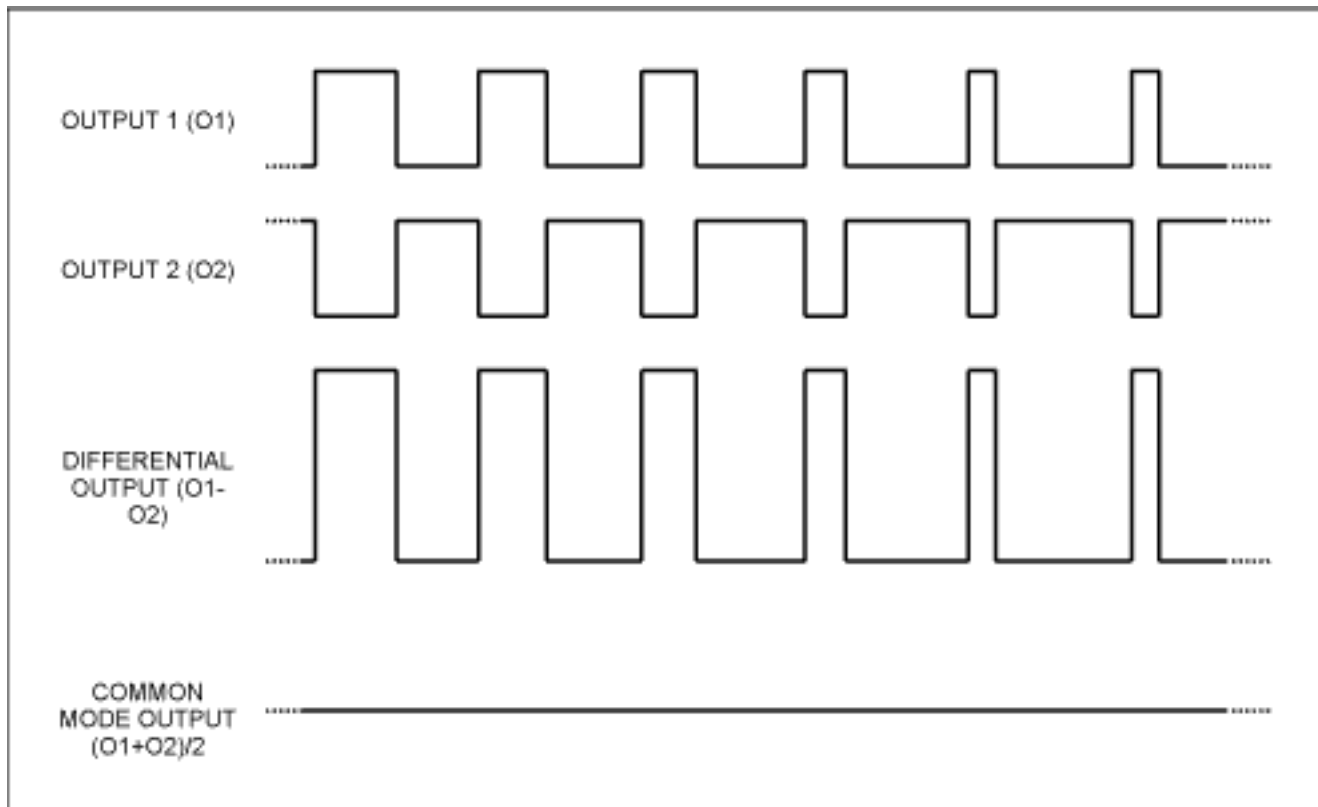

Figure 1. Waveforms of the traditional pulse-width modulation (PWM) scheme.

As Figure 1 shows, the mirror-image waveforms assert very little common-mode (CM) signal on the speaker or cables (lower trace), provided that the waveforms of the inverting and noninverting output devices are well matched. Note that a 50% duty cycle represents a zero input signal (idle). You can, therefore, design a differential lowpass filter that attenuates high-frequency content in the waveforms (due to the rapid switching), but preserves the low frequencies intended for the loudspeaker.

New Modulation Techniques

With interest in Class D amplifiers growing, several manufacturers recently introduced new modulation schemes that independently control the two halves of the H-bridge. These modulation schemes offer two key advantages:

- Virtually no differential switching is present across the load for very low audio signals and at idle. This improves quiescent current consumption over traditional PWM designs.

- The minimal pulse, CM switching helps make the turn-on and turn-off transients lower in level. The DC idle level (post filtering) on each of the BTL 'legs' is close to GND. Any mismatch, therefore, from filter components or stray capacitance (which can cause audible click-and-pop when the amp is enabled or disabled) is minimized.

Clearly, there are some advantages to the new techniques, but the amplifier outputs are no longer mirror images of each other. The waveforms shown in **Figure 2** (representing the MAX9704 stereo Class D amplifier) have a high level of common-mode content.

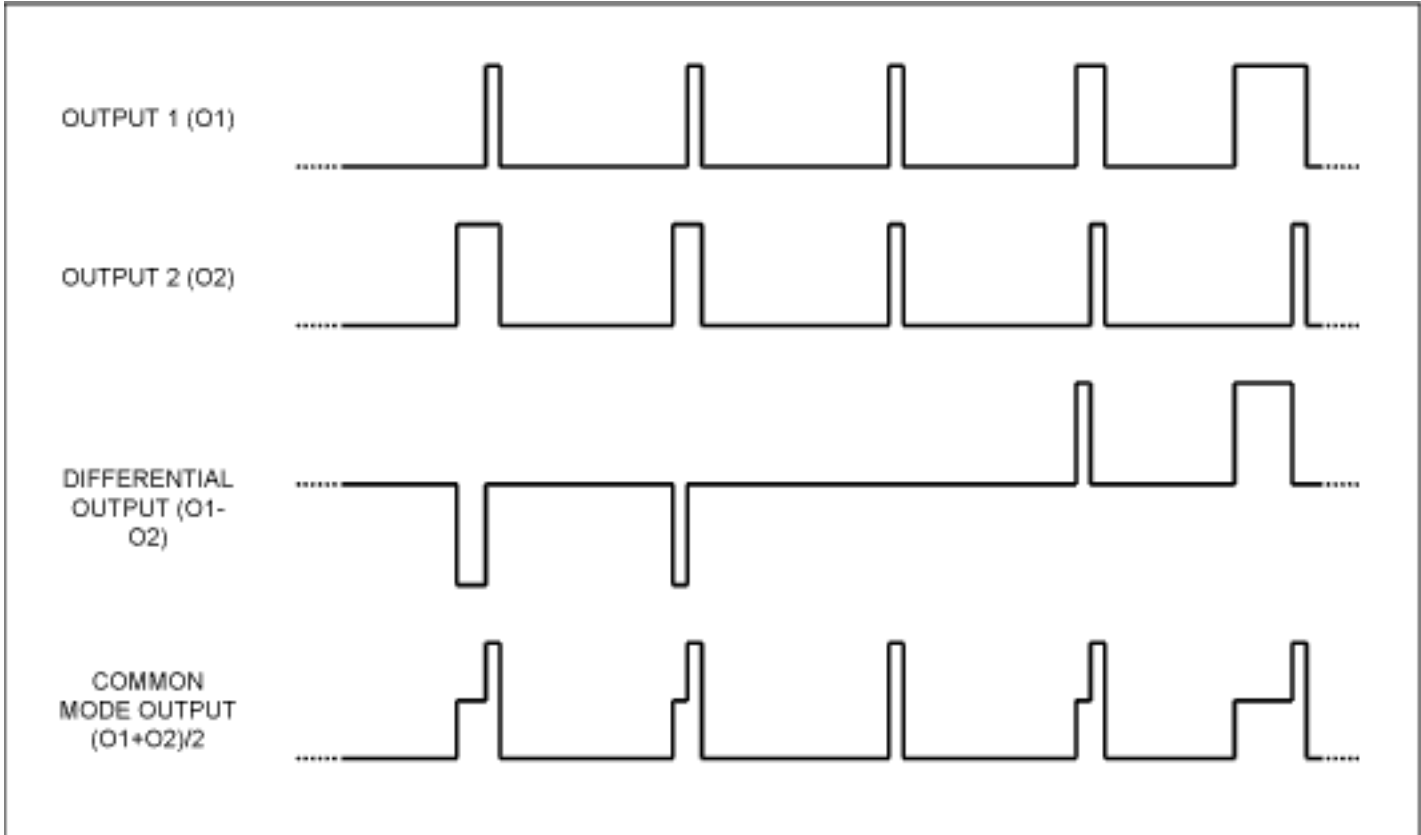
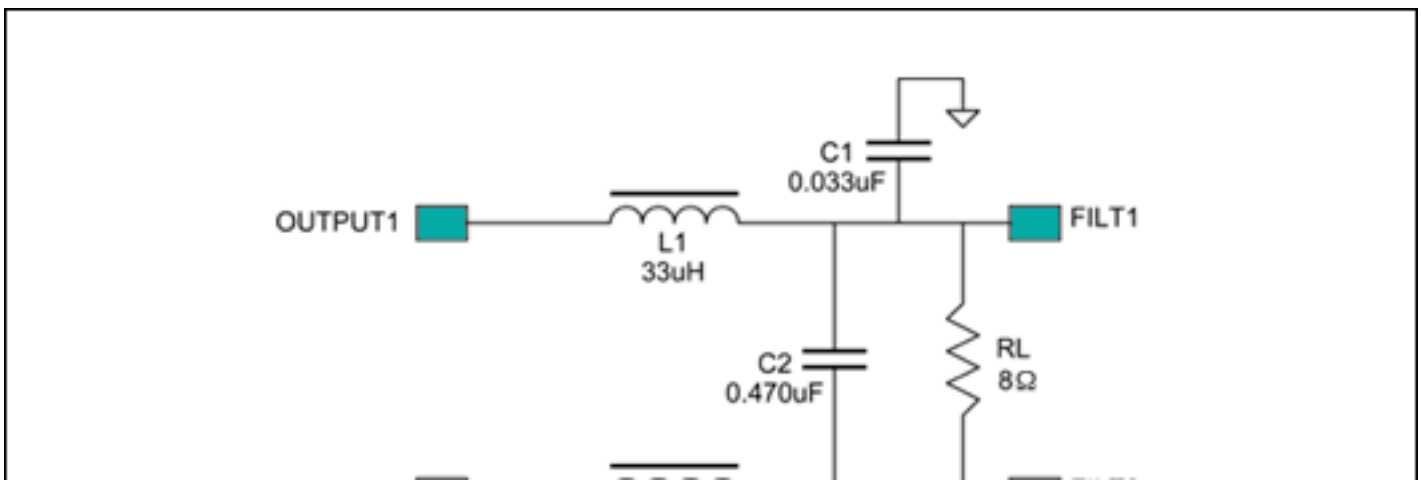

Figure 2. Modulation scheme for Maxim's MAX9704 stereo Class D amplifier.

The output-filter requirements for these Class D amplifiers differ, from those requirements for an amplifier with the traditional differential and complementary PWM outputs. Compared with PWM, the MAX9704's modulation scheme includes a high level of CM signal, and any output-filter design should take that into account. A traditional differential filter topology can give poor results, as the following example shows.

Figure 3a depicts a traditional LC, PWM, Class D output filter, implemented with ideal values. For simplification, the speaker load is represented as a pure 8Ω resistance and the inductors' DC resistance is assumed to be negligible. **Figure 3b** shows the response of the Figure 3a filter driven by a differential input signal. Each output node (FILT1, FILT2) is plotted with respect to GND. The values chosen give a second-order slope above 30kHz and a well-controlled transition. Group delay is flat across the audio band at approximately $4\mu\text{s}$.



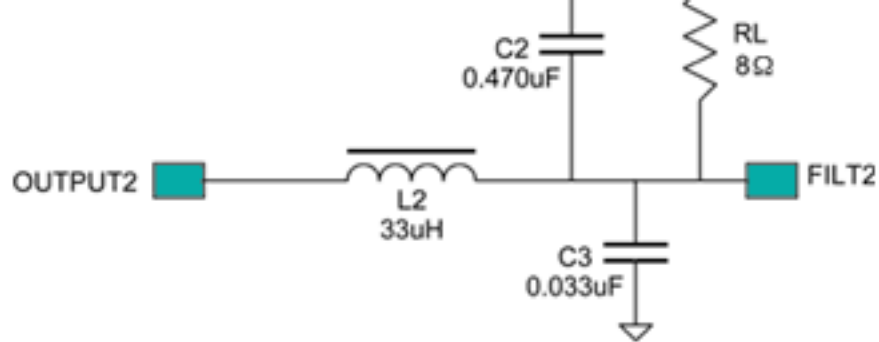

Figure 3a

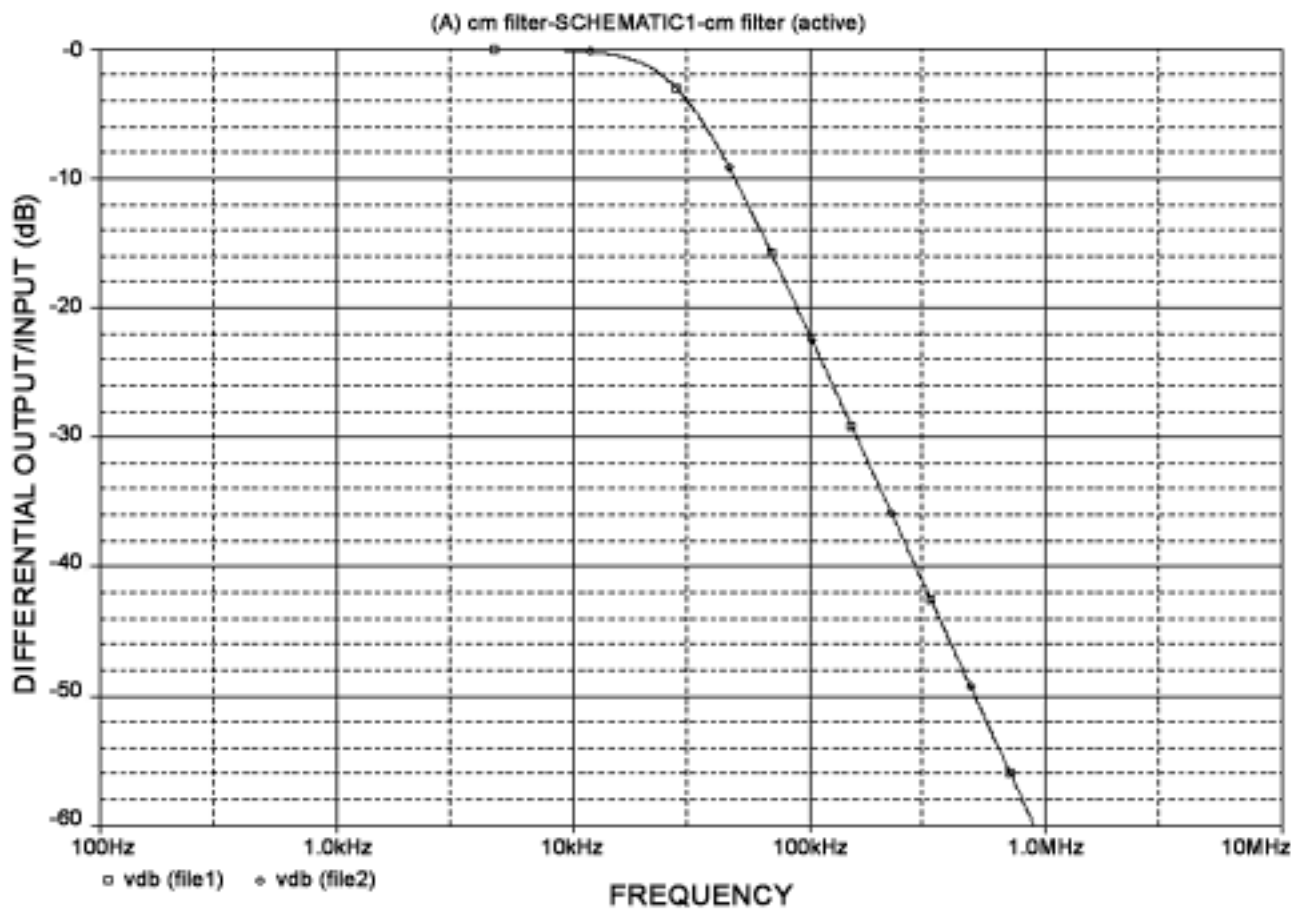
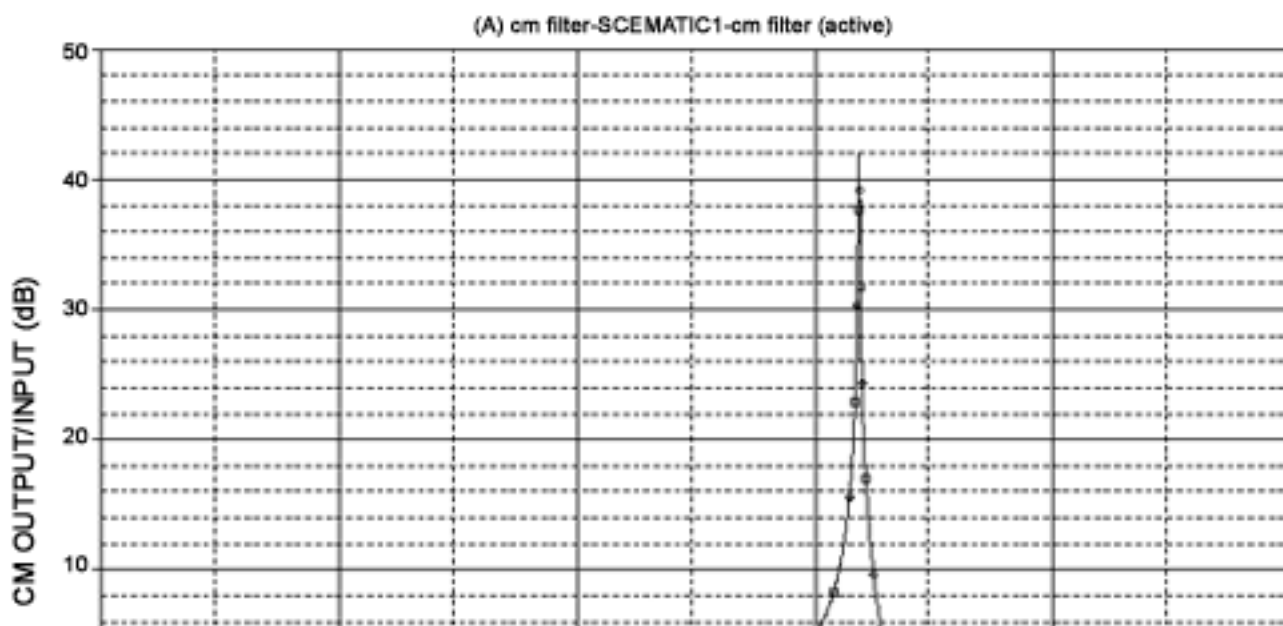

Figure 3b



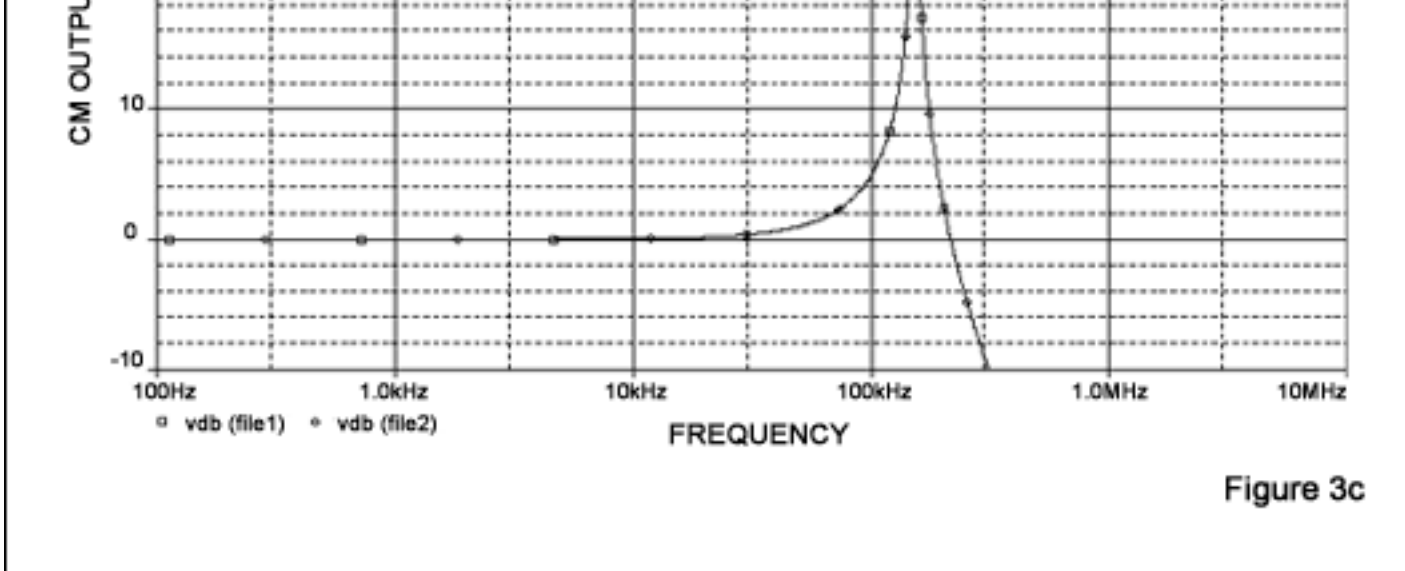

Figure 3. The response of a traditional differential-mode passive LC filter (a) is different for differential-input signals (b) and common-mode signals (c).

Figure 3c shows the same filter output driven with a CM signal. Again, each output is plotted with respect to GND. The result (note the shifted Y axis!) is heavily peaked and obviously very underdamped. That result is easily understood by considering how the filter appears to a CM signal (**Figure 4**). Because the simulation provides ideally matched inductors and capacitors, the differential signal across the resistive load is zero, and subsequently has no damping effect on the LC components. L1 interacts with C1 (as does L2 with C3) to give the peaked response. In the time domain (not shown) this condition would indicate heavy overshoot and ringing. Note also that C2 makes a zero contribution when driven by CM. This means that the filter's cut-off frequency (or more accurately stated in this case, its resonant frequency) is higher than that of the differential case.

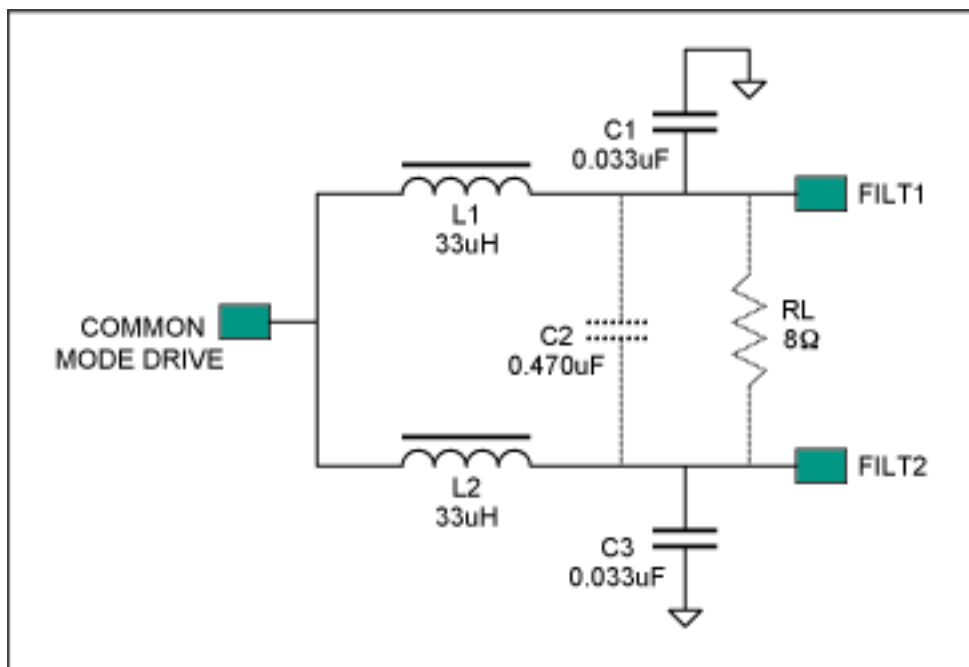

Figure 4. The traditional LC filter of Figure 3a looks like this to a common-mode signal.

At this point you can ask, is this a problem? Probably not, if the output spectrum has zero common-mode energy at that frequency. If, however, the peaking frequency coincides with the Class D switching frequency, large voltage-output excursions can appear at the speaker and the cabling. Further, the MAX9704 in its spread-spectrum-modulation (SSM) operating mode can excite the underdamped filter by producing appreciable noise energy above the audio band. Spread Spectrum Mode is a pin-selectable option in which the high-frequency switching energy is 'whitened' and lowered in amplitude by randomizing the switching period on a cycle-to-cycle basis. This spread-spectrum approach also eases EMI compliance in a filterless design.

Possible Solutions to the Underdamped CM Response

One solution to this CM problem is to preserve the basic architecture of Figure 3a, but add damping elements that suppress the highly resonant common modes. **Figure 5a** shows the addition of two series RC elements from each output node to GND. If efficiency is not important in your application, you can simply add resistors to GND, but capacitors C4 and C5 help to minimize excessive power dissipation in R1 and R2.

The values of C4 and C5 impose a tradeoff; they must be large enough to allow R1 and R2 to damp out the peaking, but small enough to minimize the power loss at high audio frequencies (usually up to 20kHz). This tradeoff is made easier if the CM cutoff frequency is much higher than the differential-mode frequency, a condition implemented by increasing the ratio of C2 to C1 and C3. By increasing the CM cutoff frequency, C4 and C5 can be smaller and R1 and R2 larger, thereby minimizing the audio-frequency power loss into R1 and R2. Pushing the CM cutoff frequency too high allows more CM on the cables> You must, therefore, determine a reasonable limit in the ratio between the differential and CM -3dB points. For this filter, we adopted 1:5 for that ratio.

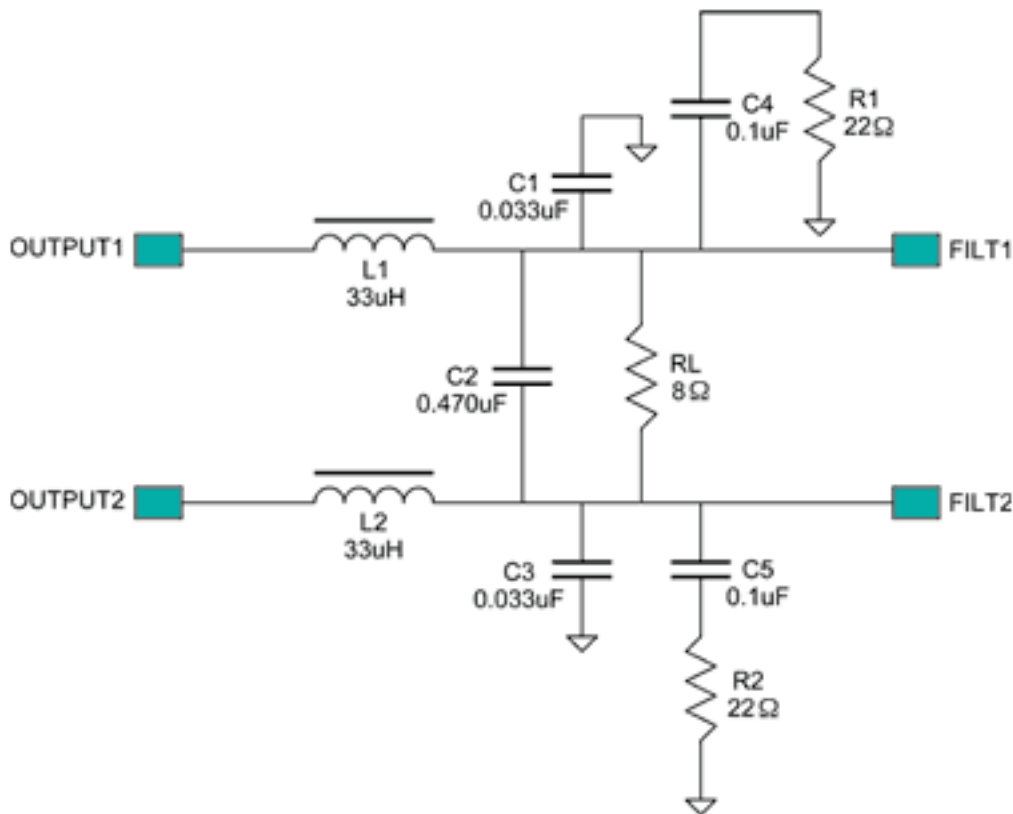
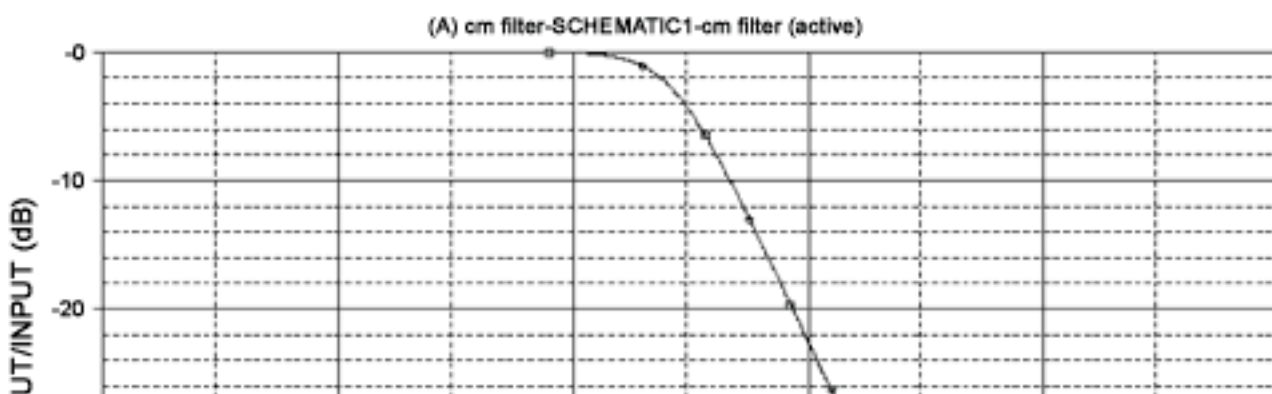

Figure 5a



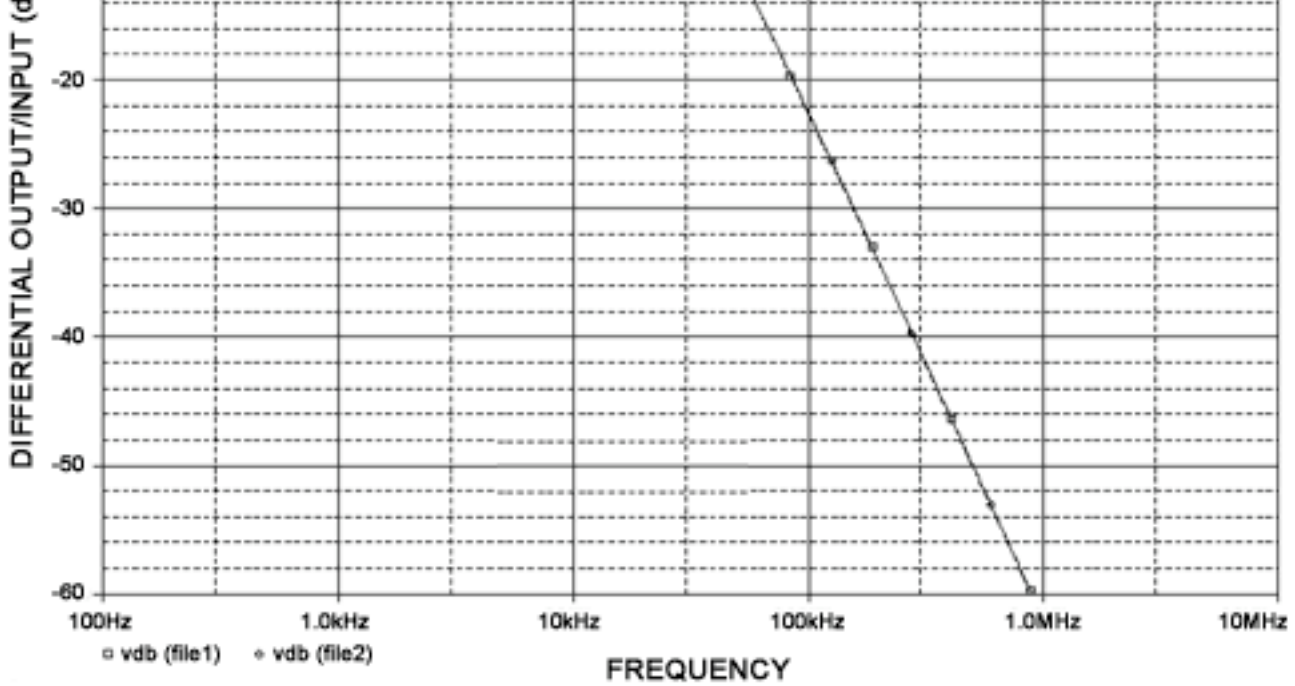

Figure 5b

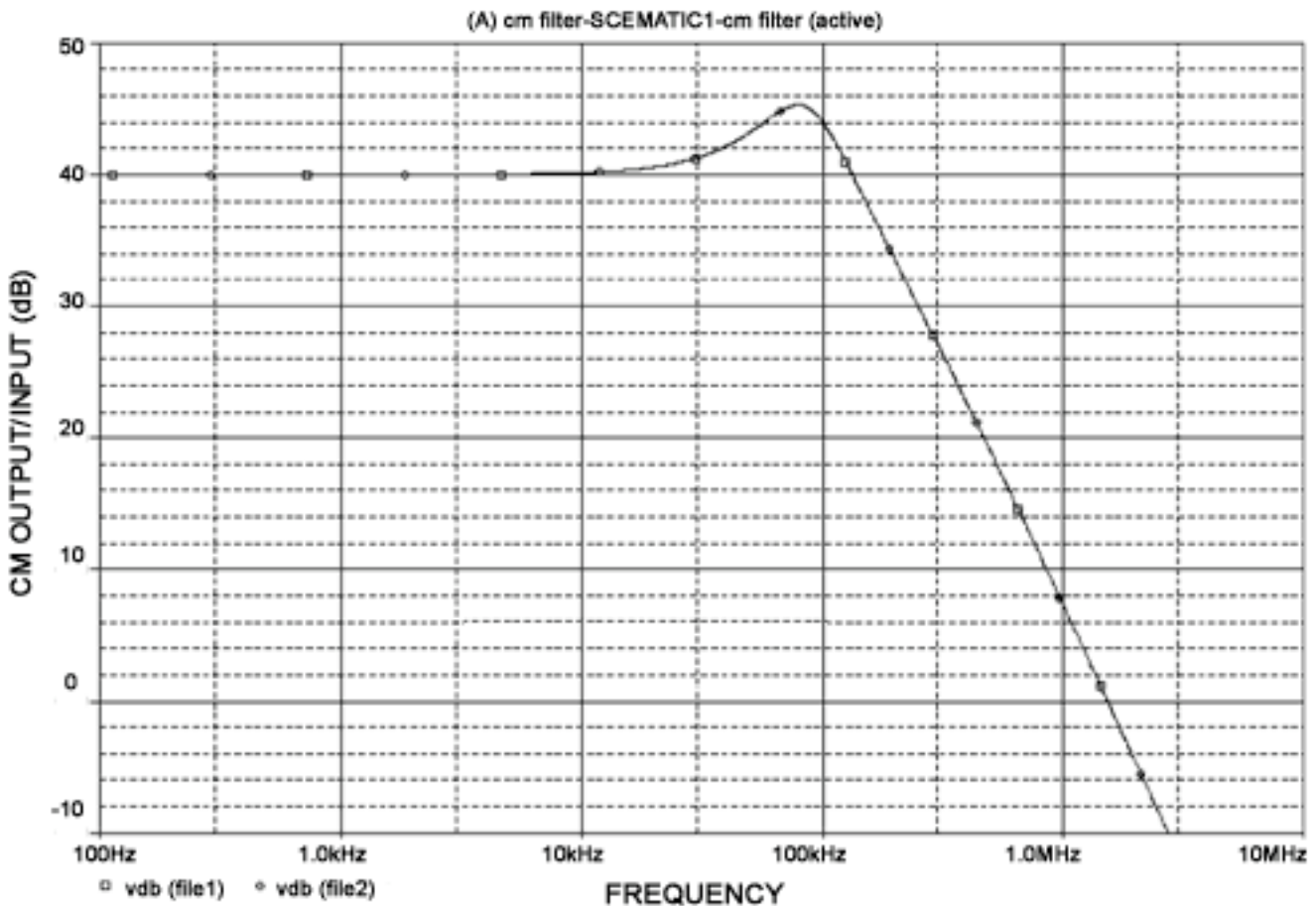

Figure 5c

Figure 5. Adding an RC network on each output of the traditional LC filter (a) improves the response for differential signals (b) and CM signals (c).

Figure 5b shows the filter of Figure 5a driven differentially, and Figure 5c shows the response when driven by CM. Note now the higher frequency CM cutoff in Figure 5c (-3dB at around 110KHz vs. 28kHz for the differential

case), with gentle but well-controlled peaking. This cutoff is well above the highest audio frequencies (and below the Class D switching-frequency fundamental), so it should be of little consequence.

Some applications with low switching frequencies (200kHz to 300kHz) will not work well with the approach shown in Figure 5c. For those products you may need to adopt other methods and topologies. The MAX9704 stereo, Class D amplifier (**Figure 6**) gives best results when set for Fixed Frequency Mode (FFM) operation at 940kHz (FS1 = low, FS2 = high). FFM in the MAX9704 sets the switching period at a constant value, pin selectable among three values, to suit a given application.

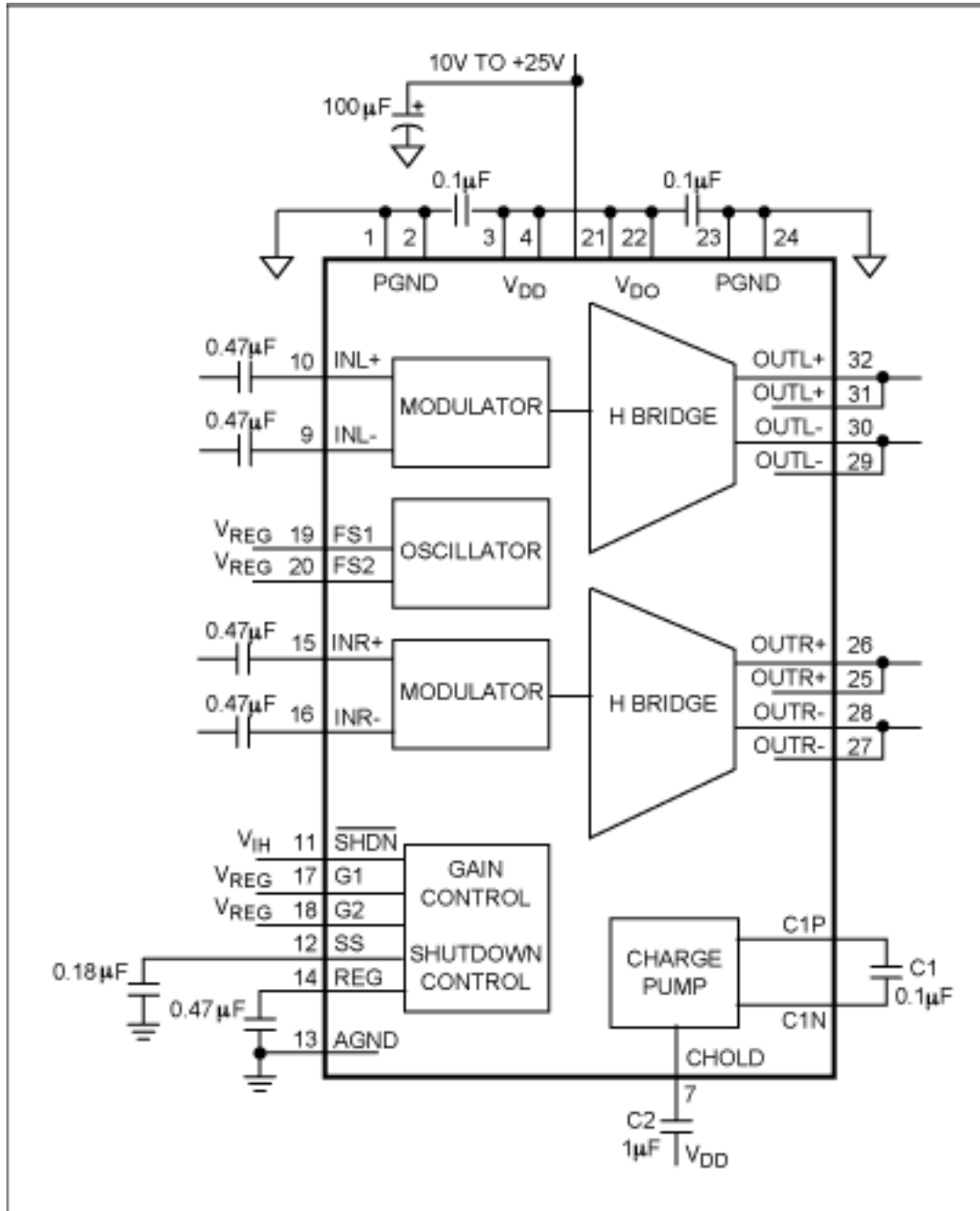

Figure 6. Typical application circuit for the MAX9704, stereo Class D power amplifier.

Figure 7 and **Figure 8** illustrate the time-domain performance for the Figure 5 filter when driven by the MAX9704. A resistive 8Ω load was used in both cases. Figure 7 shows the FILT1 and FILT2 nodes overlaid (top traces), and the resulting 1kHz differential output waveform (lower trace). Noise on the upper traces is the residual of the output switching after filtering. (Supply voltage is 15V.) Figure 8 shows a detail on the trace of Figure 7. Note that the ripple, mostly from the 940kHz switching frequency, appears as CM on both channels. Note also the absence of higher harmonics, which shows the effective suppression of EMI frequencies. (Radiated-EMI measurements usually start above 30MHz.)

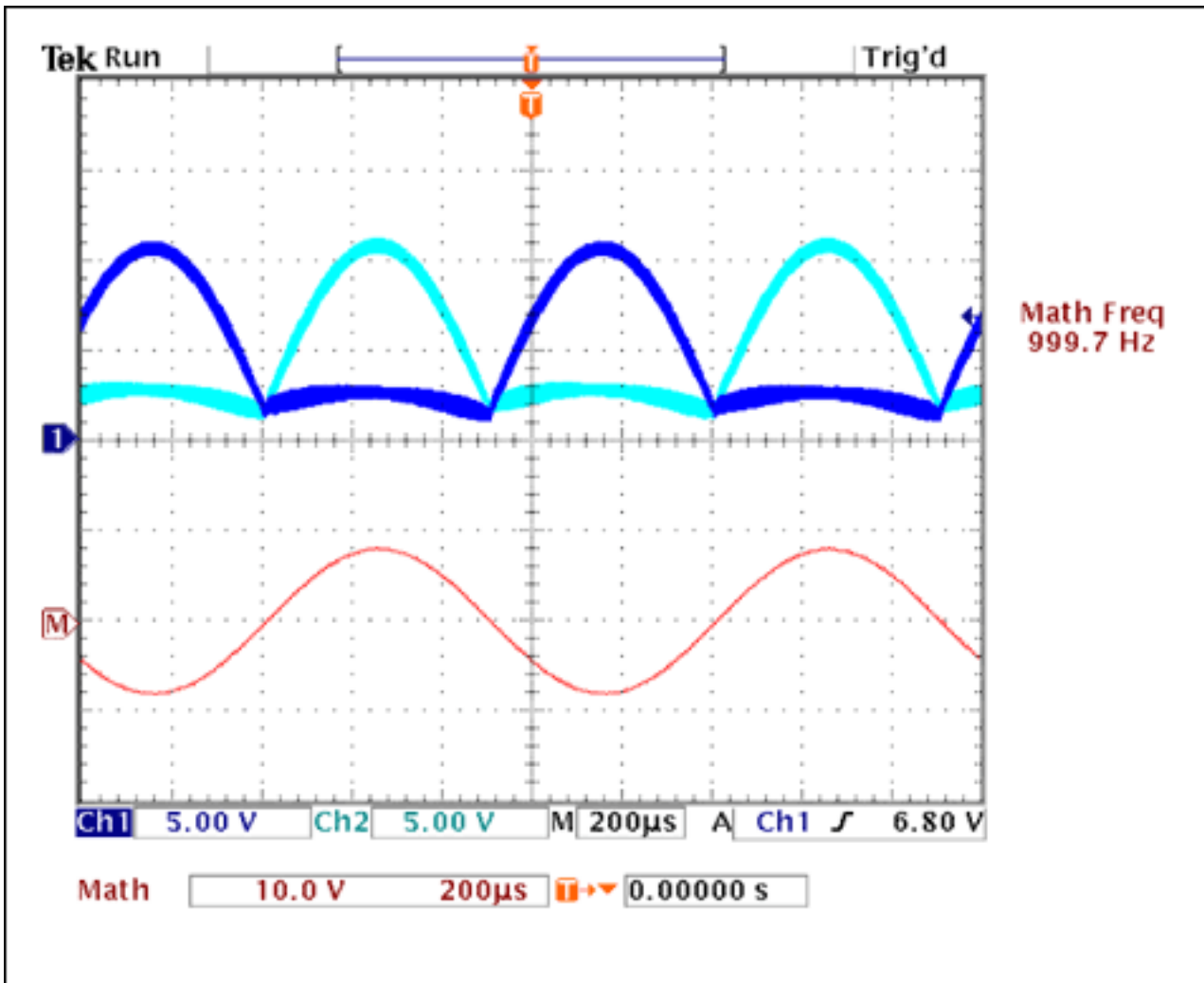

Figure 7. Driving the Figure 5a circuit with a MAX9704 produces waveforms at FILT1 and FILT2 (overlaid in the top trace) that combine as a differential output (bottom trace).

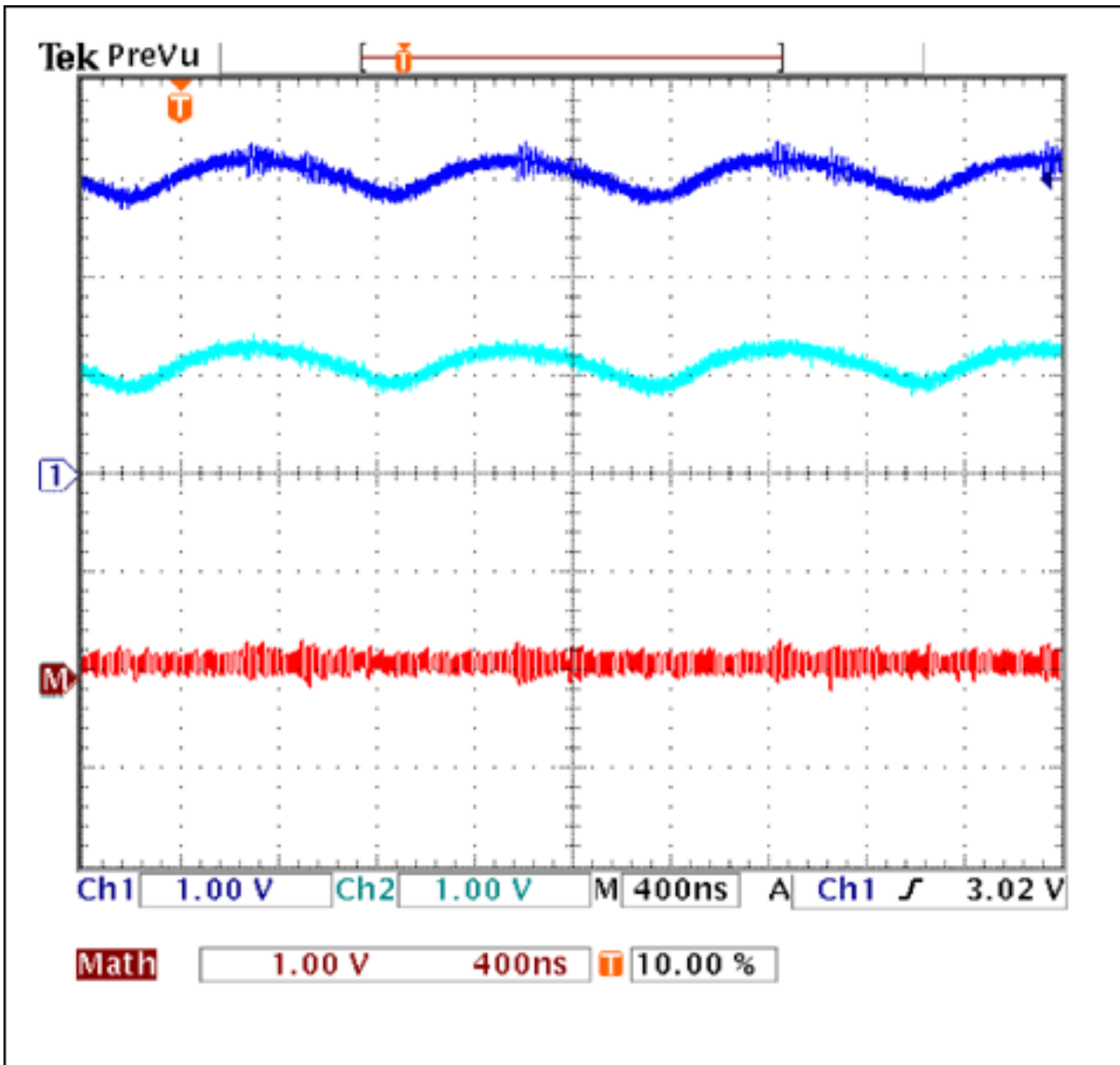

Figure 8. The top traces show residual ripple voltage at the outputs of Figure 5a, where the main ripple component is the switching-frequency fundamental (940kHz, in this case). The filter's second-order slope above that frequency heavily suppresses any higher harmonics. The ripple is almost all CM (lower trace).<

Further Notes

The filter designs in this article all assume a resistive load of 8Ω . Voice-coil inductance causes the impedance of most wide-range moving-coil loudspeakers to rise above $\sim 20\text{kHz}$. That property makes efficient filterless operation possible, but you must account for the rising impedance when optimizing the component values for any additional EMI output filtering.

When attempting to evaluate and characterize the performance of a Class D amplifier, audio designers also need to use filtering in the lab for part selection & evaluation purposes. Even if the end product can pass EMC tests without filters, the amplifier characterization can pose problems. Many audio analyzers intended for measuring THD+N or amplitude response from conventional audio amplifiers can give false results when driven by a filterless Class D amplifier. While the Figure 5 circuit is also useful on the test bench (when loaded correctly with an 8Ω resistor), note that the $33\mu\text{H}$ inductors can introduce nonlinearities that can limit THD measurements. Air-cored components give best results, but their size can limit usage in actual products!

A similar article appeared in the February 16, 2006 edition of Electronic Design.

Application Note 3878: <http://www.maxim-ic.com/an3878>

More Information

For technical questions and support: <http://www.maxim-ic.com/support>

For samples: <http://www.maxim-ic.com/samples>

Other questions and comments: <http://www.maxim-ic.com/contact>

Related Parts

MAX9704: [QuickView](#) -- [Full \(PDF\) Data Sheet](#) -- [Free Samples](#)

MAX9741: [QuickView](#) -- [Full \(PDF\) Data Sheet](#)

MAX9744: [QuickView](#)

MAX9745: [QuickView](#)

MAX9768: [QuickView](#) -- [Full \(PDF\) Data Sheet](#)

MAX9769: [QuickView](#)

AN3878, AN 3878, APP3878, Appnote3878, Appnote 3878

Copyright © by Maxim Integrated Products

Additional legal notices: <http://www.maxim-ic.com/legal>