



APPLICATION NOTE 387

## Using DS2148/DS21348 as Repeater

*Abstract: Application note 387 describes the use of the Maxim DS2148/DS21348 as a T1 or E1 repeater. A simple circuit diagram shows typical connections. Configurations for Hardware Mode and Software Mode are also provided.*

### Introduction

This application note describes the register settings for Maxim's DS2148 and DS21348 (E1/T1/J1 line interface units) as a repeater for T1 or E1 operation. This can be accomplished with the device in either hardware or software mode.

The receive sensitivity for these two LIUs is programmable and is as much as -36dB for T1 applications and -43dB for E1 applications.

To simplify the design, it is recommended to use a 2.048MHz oscillator and use the internal register settings of the DS2148 and the DS21348 to convert the MCLK to 1.544MHz for T1 applications.

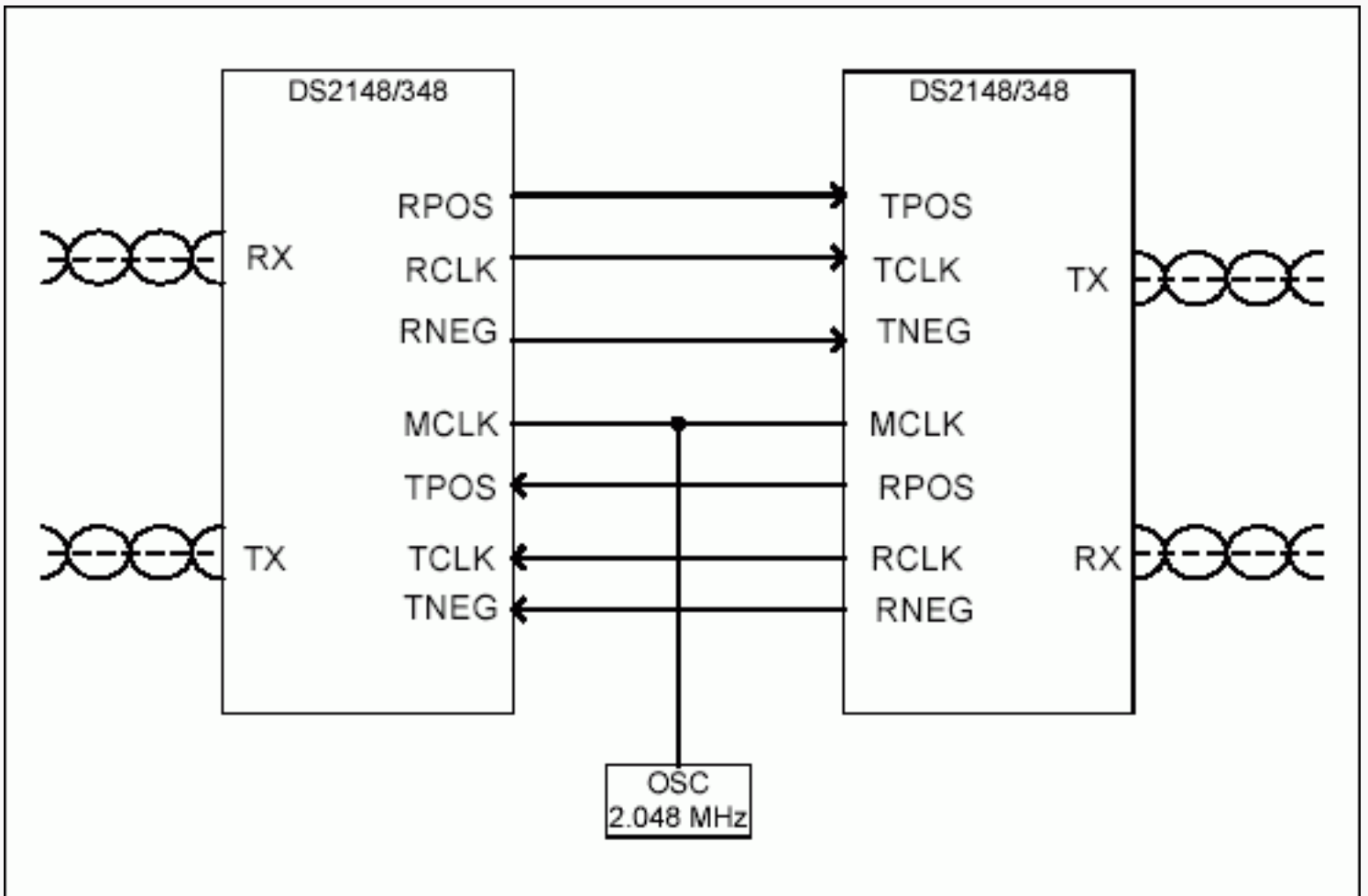

Figure 1. Typical T1/E1 repeater application.

The configuration settings of the DS2148 or the DS21348 in hardware mode are:

Hardware Mode Settings for T1	Hardware Mode Settings for E1
MCLK = 2.048MHz	MCLK = 2.048MHz
BIS1 = 1, BIS0 = 1	BIS1 = 1, BIS0 = 1
CES = 0	CES = 0
DJA = 0 or 1 ( <i>application dependent</i> )	DJA = 0 or 1 ( <i>application dependent</i> )
HBE = 1	HBE = 1
JAS = 0 or 1 ( <i>application dependent</i> )	JAS = 0 or 1 ( <i>application dependent</i> )
NRZE = 0	NRZE = 0
TPD = 0	TPD = 0
L2 = L1 = L0 = 0	L2/L1/L0 ( <i>application dependent</i> )
TX1 = 0, TX0 = 0	TX1 = 0, TX0 = 0
LOOP1 = 0, LOOP0 = 0	LOOP1 = 0, LOOP0 = 0
EGL = 1, ETS = 1 ( <i>limited long haul</i> )	EGL = 0, ETS = 0 ( <i>short haul</i> )
EGL = 0, ETS = 1 ( <i>long haul</i> )	EGL = 1, ETS = 0 ( <i>long haul</i> )
MM1 = 0, MMO = 0	MM1 = 0, MMO = 0
RT1 = 1, RT0 = 0 (internal Rx side, 100 enabled)	RT1 = 0, RT0 = 1 (internal Rx side, 120 enabled)
	RT1 = 1, RT0 = 1 (internal Rx side, 75 enabled)
JAMUX = 1, ETS = 1	JAMUX = 1, ETS = 0

The configuration settings of the DS2148 or the DS21348 in software mode are:

Software Mode Register Settings for T1		Software Mode Register Settings for E1	
MCLK = 2.048MHz		MCLK = 2.048MHz	
CCR1 (00H)	CCR1.7 = 1 CCR1.6 = 0 CCR1.3 = 1 CCR1.1 = 1	CCR1 (00H)	CCR1.7 = 0 CCR1.6 = 0 CCR1.3 = 1 CCR1.1 = 1
CCR2 (01H)	CCR2.3 = 1 CCR2.2 = 1 CCR2.1 = 0 CCR2.0 = 0	CCR2 (01H)	CCR2.3 = 1 CCR2.2 = 1 CCR2.1 = 0 CCR2.0 = 0
CCR4 (03H)	CCR4.7 = CCR4.6 = CCR4.5 = 0 CCR4.1 (application dependent) CCR4.0 = 0	CCR4 (03H)	CCR4.7, CCR4.6, and CCR4.5 (application dependent) CCR4.1 (application dependent) CCR4.0 = 0
CCR5 (04H)	CCR5.5 = 0, CCR5.4 = 0 CCR5.1 = 1, CCR5.0 = 0 (internal Rx side, 100 enabled)	CCR5 (04H)	CCR5.5 = 0, CCR5.4 = 0 CCR5.1 = 0, CCR5.0 = 1 (internal RX side, 120 enabled) CCR5.1 = 1, CCR5.0 = 1 (internal Rx side, 75 enabled)

## Related Parts

DS21348: [QuickView](#) -- [Full \(PDF\) Data Sheet](#) -- [Free Samples](#)

DS2148: [QuickView](#) -- [Full \(PDF\) Data Sheet](#) -- [Free Samples](#)

## Automatic Updates

Would you like to be automatically notified when new application notes are published in your areas of interest? [Sign up for EE-Mail™](#).

Application note 387: [www.maxim-ic.com/an387](http://www.maxim-ic.com/an387)

## More Information

For technical support: [www.maxim-ic.com/support](http://www.maxim-ic.com/support)

For samples: [www.maxim-ic.com/samples](http://www.maxim-ic.com/samples)

Other questions and comments: [www.maxim-ic.com/contact](http://www.maxim-ic.com/contact)

AN387, AN 387, APP387, Appnote387, Appnote 387

Copyright © by Maxim Integrated Products

Additional legal notices: [www.maxim-ic.com/legal](http://www.maxim-ic.com/legal)