

APPLICATION NOTE 3867

# Shunt Regulator Improves PA's Current-Limit Accuracy

*Abstract: Substituting a shunt regulator (U1) for the usual transistor in this power-amplifier circuit improves the current-limit accuracy.*

Adding current-limiting circuitry to an emitter follower protects both the pass transistor and downstream circuitry from excessive current damage. The classic way to implement such current limiting is to add a ballast resistor between the pass transistor's emitter and the circuit output, and then monitor the resistor drop with a small-signal transistor. See R4 and Q2 in the power amplifier (or linear regulator) shown in **Figure 1**.

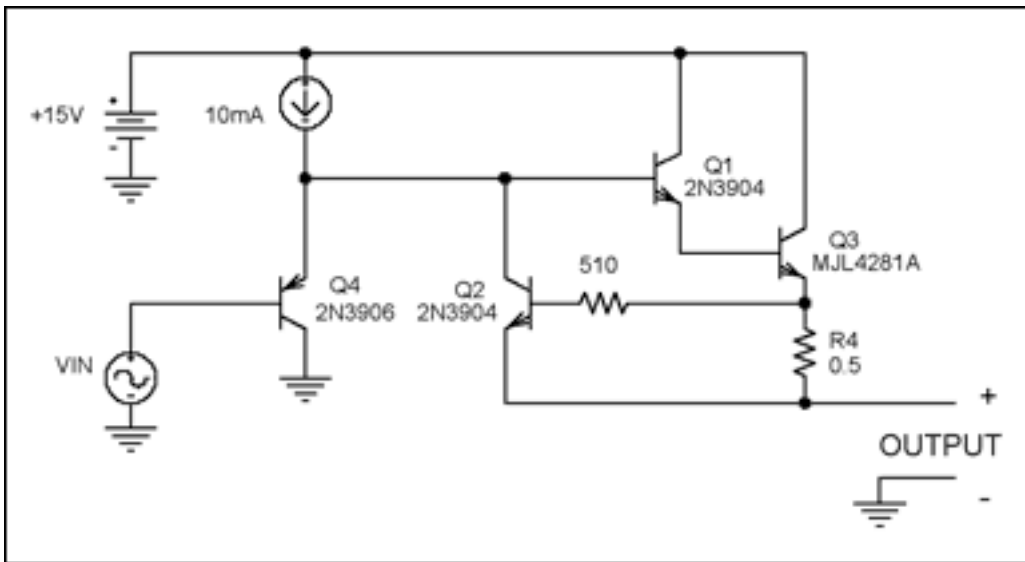

Figure 1. A small-signal transistor (Q2) provides an output current limit for this power amplifier.

Unfortunately, the base-emitter voltage of the small-signal transistor sets the current-limit threshold for this circuit. That  $V_{BE}$  has a well-known temperature coefficient of  $-2\text{mV}/^\circ\text{C}$ , which causes a substantial change in current limit across the operating temperature range.

An adjustable shunt regulator (U1 in **Figure 2**) is preferable to the small-signal transistor for sensing current. This IC is chosen for its low-input threshold (0.6V), which is lower than that of common shunt regulators (1.25V to 2.5V). In addition, the IC's separate power-supply input allows it to maintain accuracy as the internal output transistor approaches saturation.

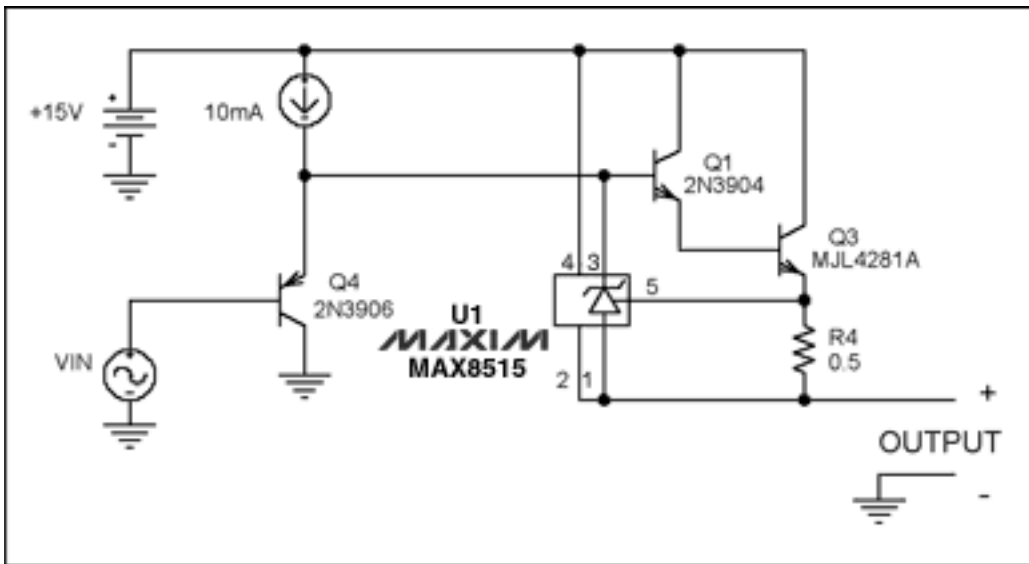

Figure 2. Substituting a shunt regulator (U1) for Q2 in the Figure 1 circuit improves the current-limit accuracy.

**Figure 3** compares current-limit accuracies of the small-signal-transistor version of Figure 1 with the shunt-regulator version of Figure 2. The transistor version exhibits a 25% change in current-limit threshold over the operating temperature range, while the shunt-regulator provides better than 2% accuracy over that range (neglecting the temperature coefficients of the sense resistors).

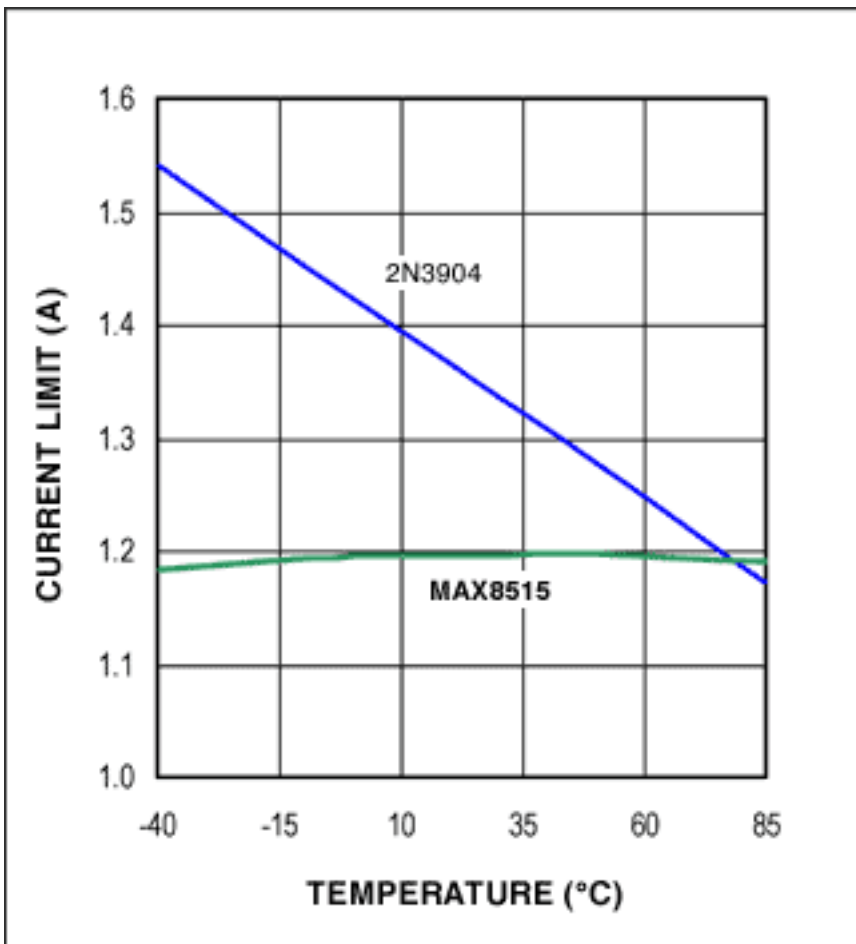

Figure 3. Current-limit accuracy versus temperature for the circuits of Figure 1 (top trace) and Figure 2 (bottom trace).

A similar article appeared as a Design Idea in the February 2, 2006 edition of *EDN*.

Application Note 3867: [www.maxim-ic.com/an3867](http://www.maxim-ic.com/an3867)

### **More Information**

For technical support: [www.maxim-ic.com/support](http://www.maxim-ic.com/support)

For samples: [www.maxim-ic.com/samples](http://www.maxim-ic.com/samples)

Other questions and comments: [www.maxim-ic.com/contact](http://www.maxim-ic.com/contact)

---

### **Automatic Updates**

Would you like to be automatically notified when new application notes are published in your areas of interest?

[Sign up for EE-Mail™.](#)

---

### **Related Parts**

MAX8515: [QuickView](#) -- [Full \(PDF\) Data Sheet](#) -- [Free Samples](#)

AN3867, AN 3867, APP3867, Appnote3867, Appnote 3867

Copyright © by Maxim Integrated Products

Additional legal notices: [www.maxim-ic.com/legal](http://www.maxim-ic.com/legal)