

APPLICATION NOTE 3831

Memory Card Interface Translates and Protects Signals

Abstract: This application note explains how to use the MAX13030E–MAX13035E logic-level translators as a memory-card level translator. An example circuit illustrates the advantages of the devices.

The circuit shown in **Figure 1** shows how the [MAX13030E–MAX13035E](#) logic-level translator ICs translate the logic level of the memory-card signals, while protecting the signals against ESD strikes of up to $\pm 15\text{kV}$ HBM (Human Body Model). The MAX13035E, for example, takes the 1.8V signals from any memory-card controller (for example, in a baseband processor, application processor, or multimedia processor) and automatically translates them to 3.3V. The device can perform the reverse process too. This circuit can be used for SD cards, MMC, Transflash® (microSD), MiniSD, MemoryStick, MemoryStick PRO, and similar memory cards.

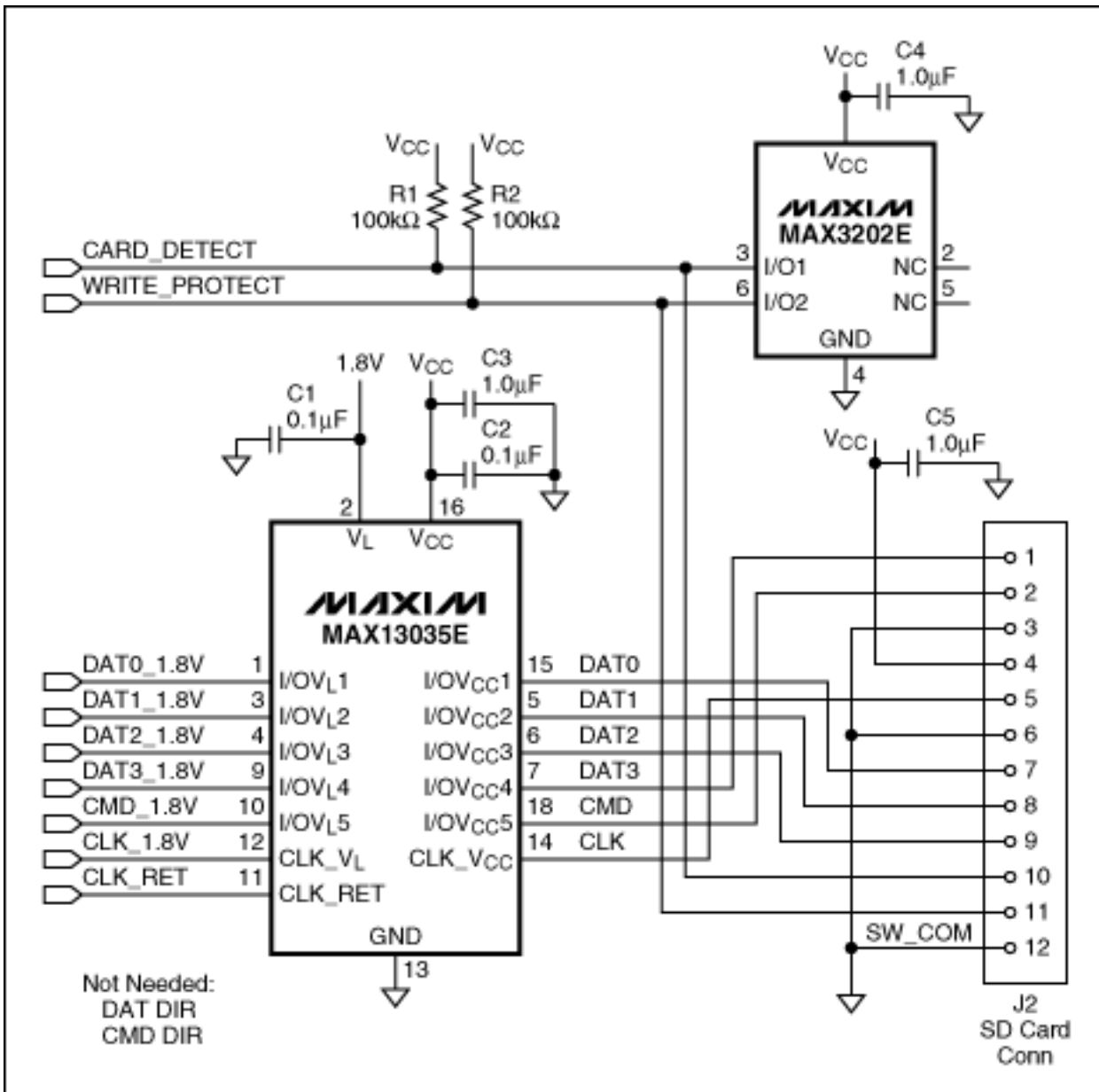

Figure 1. Logic-level translator circuit for memory cards. The pinout shown at J2 is for SD cards.

These devices use a proprietary architecture, which eliminates the need for a direction (DIR) or write/read (W/R) pins to indicate data direction. This approach has several benefits. First, the package size of the MAX13035E family of parts is reduced to only 2mm x 2mm in a 16-bump UCSP because fewer signals are needed. Second, the I/O on the baseband processor that would have been used to indicate the direction of the signals is now free to be used for something else. Finally, one fewer signal has to be routed in what is undoubtedly a tightly packed layout.

The proprietary architecture of the MAX13035E also uses internal current sources to guarantee a known state on the bus when the inputs are high impedance. This design eliminates the need for external pull-up or pull-down resistors. Each channel is interchangeable, and compatible with either CMOS push-pull signals of up to 50MHz (100Mbps) or open-drain signals at 200kHz (400kbps). This flexibility is especially useful when interfacing to memory cards like the MMC where the initialization mode can use open-drain signaling on one of the lines.

The MAX13035E and the other devices in the MAX13030E family of parts all shutdown when $V_{CC} < V_L$, that is when V_{CC} is disconnected. The MAX13030E–MAX13034E include an EN pin that can be driven low to put the part in a lower power shutdown state. The MAX13035E, however, does not include an EN pin, but replaces it with a CLK_RET pin whose function is to feedback the clock signal to the host processor, as shown in **Figure 2**. This

signal can be used by certain SD card controllers to improve performance.

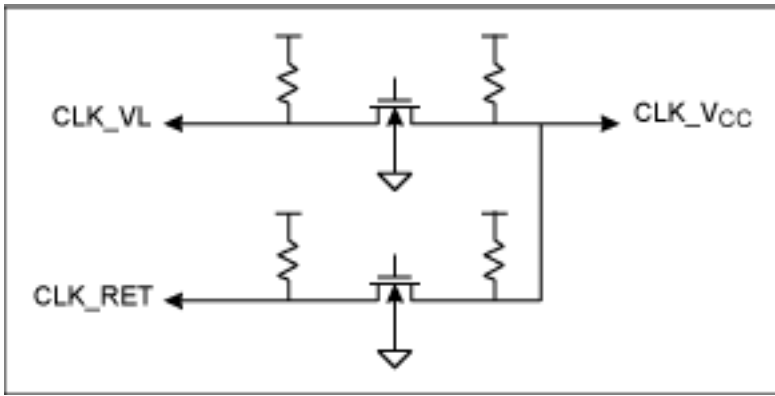

Figure 2. The MAX13035E uses a CLK_RET pin to feed the clock signal back to the host processor.

All devices in the MAX13015E family include extended ESD protection of up to $\pm 15\text{kV}$ (HBM) for all I/O lines on the V_{CC} side (card side). To guarantee full ESD protection, a $1\mu\text{F}$ ceramic capacitor should be used to bypass V_{CC} .

The circuit in Figure 1 also shows how to use the [MAX3202E](#) to provide ESD protection on the CARD_DETECT and WRITE_PROTECT signals. When using this circuit, it is strongly recommended that you use the CARD_DETECT provided by the SD card connector rather than the pull-up resistor on DAT3. This is because the MAX13035E is not compatible with the pull-up technique of card detection.

Application Note 3831: <http://www.maxim-ic.com/an3831>

More Information

For technical questions and support: <http://www.maxim-ic.com/support>

For samples: <http://www.maxim-ic.com/samples>

Other questions and comments: <http://www.maxim-ic.com/contact>

Related Parts

MAX13030E: [QuickView](#) -- [Full \(PDF\) Data Sheet](#)

MAX13031E: [QuickView](#) -- [Full \(PDF\) Data Sheet](#)

MAX13032E: [QuickView](#) -- [Full \(PDF\) Data Sheet](#)

MAX13033E: [QuickView](#) -- [Full \(PDF\) Data Sheet](#)

MAX13034E: [QuickView](#) -- [Full \(PDF\) Data Sheet](#)

MAX13035E: [QuickView](#) -- [Full \(PDF\) Data Sheet](#)

AN3831, AN 3831, APP3831, Appnote3831, Appnote 3831

Copyright © 2007 by Maxim Integrated Products

Additional legal notices: <http://www.maxim-ic.com/legal>