

APPLICATION NOTE 3811

Simple Devices for Meeting Voltage Tracking Requirements

Abstract: This application note discusses different techniques and architectures for tracking voltages during power-up and power-down. Examples of low-cost solutions and more complex, integrated EEPROM-configurable solutions are provided.

In high-power, multivoltage systems, it is often necessary that supply voltages track during power-up and power-down. This prevents latchup conditions that can cause immediate damage or even latent damage that produces failures in the field.

Simple discrete diodes can impose the necessary tracking in simple applications, but diodes are inadequate for more complex systems that include more than two supply voltages. Increasing levels of current flow in state-of-the-art ASICs require larger external diodes to manage power dissipation and, for low-cost diodes, this means a higher forward voltage and greater power dissipation.

One easy voltage-tracking solution is to use regulators with voltage outputs designed to track each other during power-up. Such regulators are adequate for power-up, but systems often require the tracking of falling supply voltages also when the system shuts down. Another important consideration during shutdown is the need to discharge large capacitors to prevent current from inadvertently flowing through critical ICs. As a result, it is important to be able to control voltage during both the power-up and power-down process.

Thus, supply-voltage tracking is required not just during turn-on, but also for determining how fast the supplies are turned on and what happens when a fault is detected.

The Simple, Low-Cost Approach

Perhaps the easiest voltage-tracking method is to turn on two external pass elements at the same time (**Figure 1**). This application circuit monitors the two voltages and, at turn-on, activates a charge pump to fully enhance (turn-on) two external n-channel MOSFETs. If the outputs start from an unpowered state, the voltages turn on at nearly the same time as the gate-to-source enhancement. There may be a slight voltage differential due to offsets between the two external MOSFETs, but dual n-channel MOSFETs in the same package would likely yield a fairly small offset.

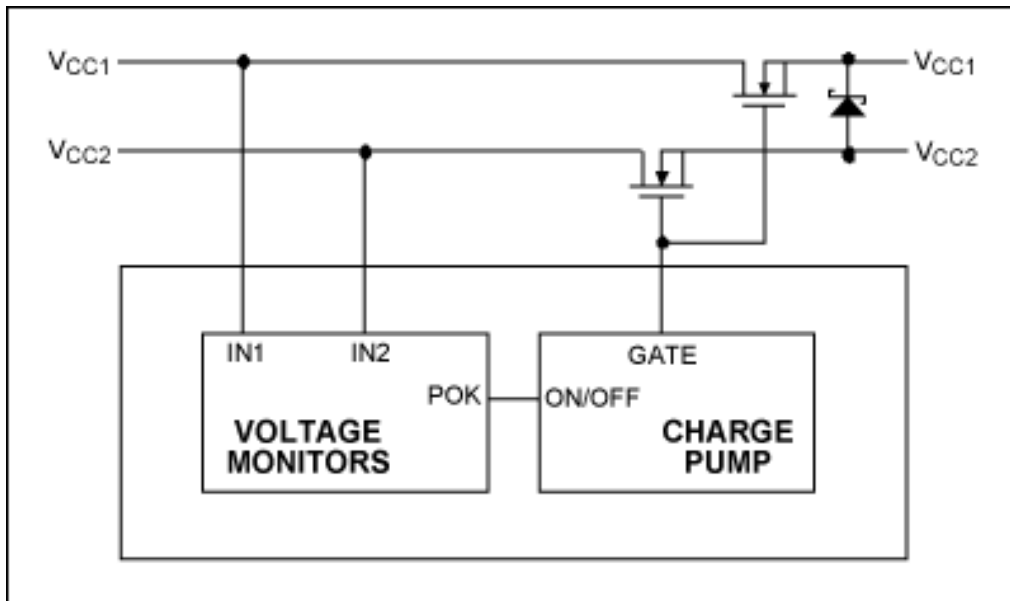

Figure 1. This open-loop voltage tracker uses a single charge pump to turn on two voltages simultaneously.

This circuit provides a relatively low-cost, "pseudo" open-loop voltage tracker adequate for a variety of simple applications. Some of today's ICs provide the ability to monitor supply voltages, and also integrate an internal charge pump that can be used for this tracking function. The [MAX6819/MAX6820](#) power-supply sequencers, for example, can monitor a voltage and, when the voltage is within specifications, start a charge-pump circuit to turn on the external n-channel MOSFETs.

The scope photo in **Figure 2** illustrates the rising supply voltages V_{CC1} and V_{CC2} (upper right corner of the open-loop configuration shown in Figure 1) as controlled by the MAX6819 through two external n-channel MOSFETs (IRF7380). The supply voltages track each other within 200mV, a difference mainly attributable to the MOSFETs' gate-to-source turn-on thresholds, but that is adequate for most situations.

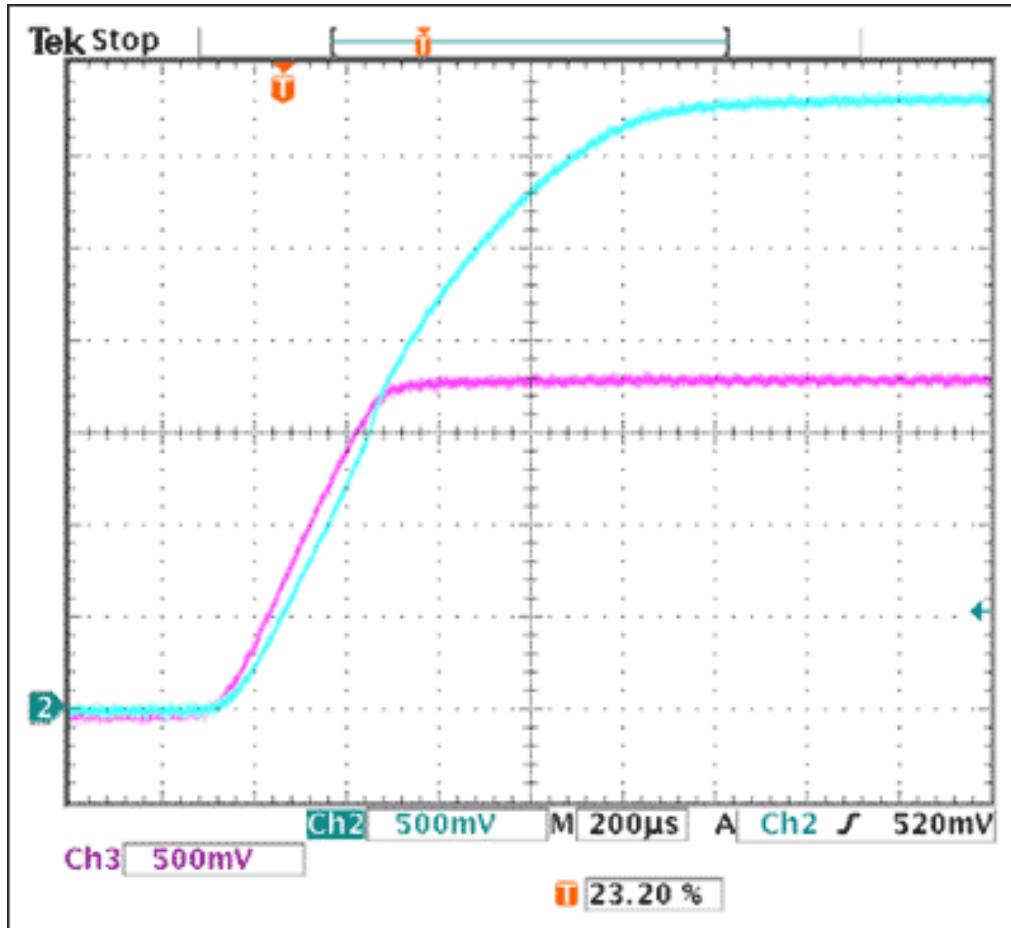

Figure 2. Scope photo of output voltages in the open-loop tracking architecture of Figure 1, as controlled by the MAX6819 system-management device.

Design issues include MOSFET size (to accommodate maximum current), drain-to-source resistance (to determine loss across the MOSFET), and gate charge (to determine the voltage ramp rate). The circuit provides a 5.5V gate-to-source enhancement that allows the use of logic-level MOSFETs for high-current applications. To control the inrush current and rate of rise, you can slow down the voltage ramp by adding a small capacitor between the gate and ground. During power-up, the voltages track until the lower voltage reaches its nominal level. The higher voltage then continues toward its final value.

Voltage tracking can be more difficult on power-down, because the difference in output voltages may cause one MOSFET to begin turning off slightly before the other. Different capacitive and output loads on the supply lines can also affect ramp-down rates for the two voltages. To ensure that they track each other during power-down, you can clamp them together by connecting a diode across the supply lines. Connecting the anode to the lower voltage ensures that the diode does not conduct during normal operation. This low-cost "pseudo tracker" is simple to implement, but its open-loop architecture does not ensure complete regulation.

Shunt-Voltage Trackers

The previous method uses external n-channel MOSFETs as pass elements. Although numerous n-channel MOSFETs provide a relatively low drain-to-source resistance when fully enhanced, their voltage drop at high current still wastes

power and reduces output voltage across the load. If, for example, V_{CC2} in Figure 1 is a 1.2V core supply and the expected output current is 20A at maximum operating conditions, the drop across a 5m Ω MOSFET could be 100mV. The resulting 8.125% drop in supply voltage could, if monitored, cause a system reset. If the cost can be justified, you can reduce loss across the pass element by choosing MOSFETs with lower drain-to-source resistance, or by connecting multiple MOSFETs in parallel.

One method of reducing loss across the switch is to choose an architecture that omits the series pass element. A controller circuit featuring a shunt that temporarily shorts the outputs together as they ramp up, for instance, ensures virtually no differential voltage across the two supplies. The shunt turns off after the lowest voltage reaches its final level, removing the temporary short and allowing the higher voltage to reach its final value. The absence of a series MOSFET allows the circuit to operate at full load without series loss. Furthermore, the n-channel MOSFET used as a shunt can be of modest size, because the power required during startup is (usually) considerably less than that during normal operation.

This architecture also tracks declining voltages during power-down (**Figure 3**). Systems with more than two supply voltages can employ multiple voltage-tracking controllers. The configuration operates well regardless of the DC-DC regulators used, the amount of output capacitance present (except for its effect on ramp rate), and which supply is turned on first.

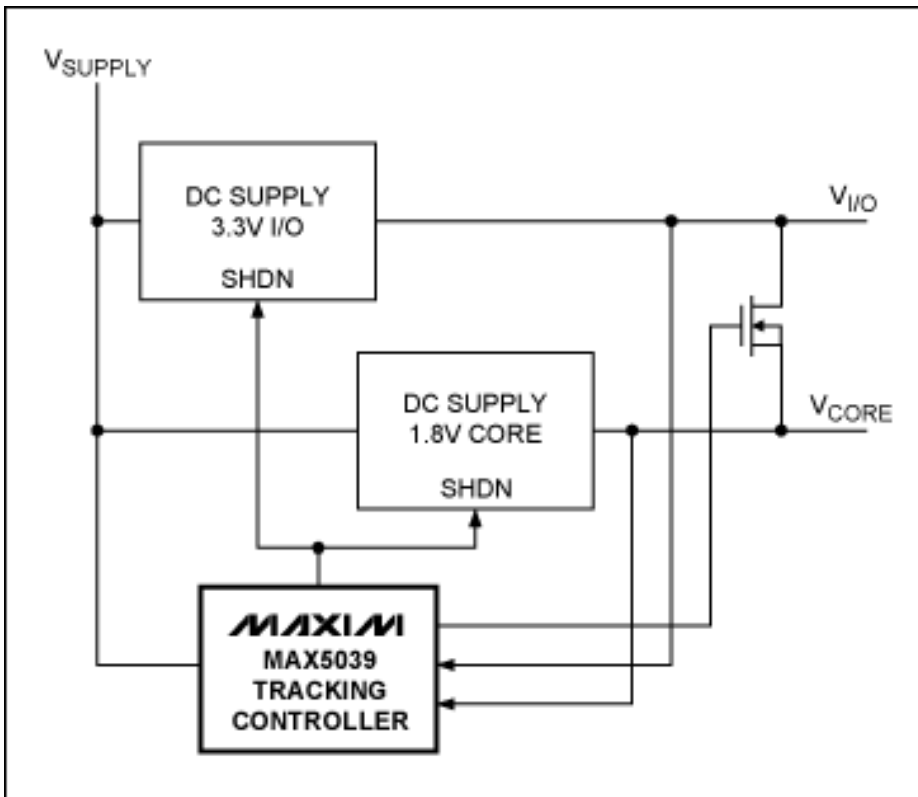

Figure 3. The MAX5039 tracking controller shown reduces power dissipation in this shunt-voltage-tracking architecture.

A key feature of the MAX5039 voltage-tracking controller is its feedback input, CORE_FB. Using a simple resistor-divider network, the device tracks the supply voltage during power-up, turns off the MOSFET when the I/O supply exceeds the core voltage, and turns the MOSFET back on when the I/O supply falls below the core supply. Thus, it provides tracking capability during power-down and fault conditions. It also includes a fault-detection input that connects the voltages by latching the gate to V_{CC} . You can also track three voltages by connecting multiple MAX5039s together (**Figure 4**).

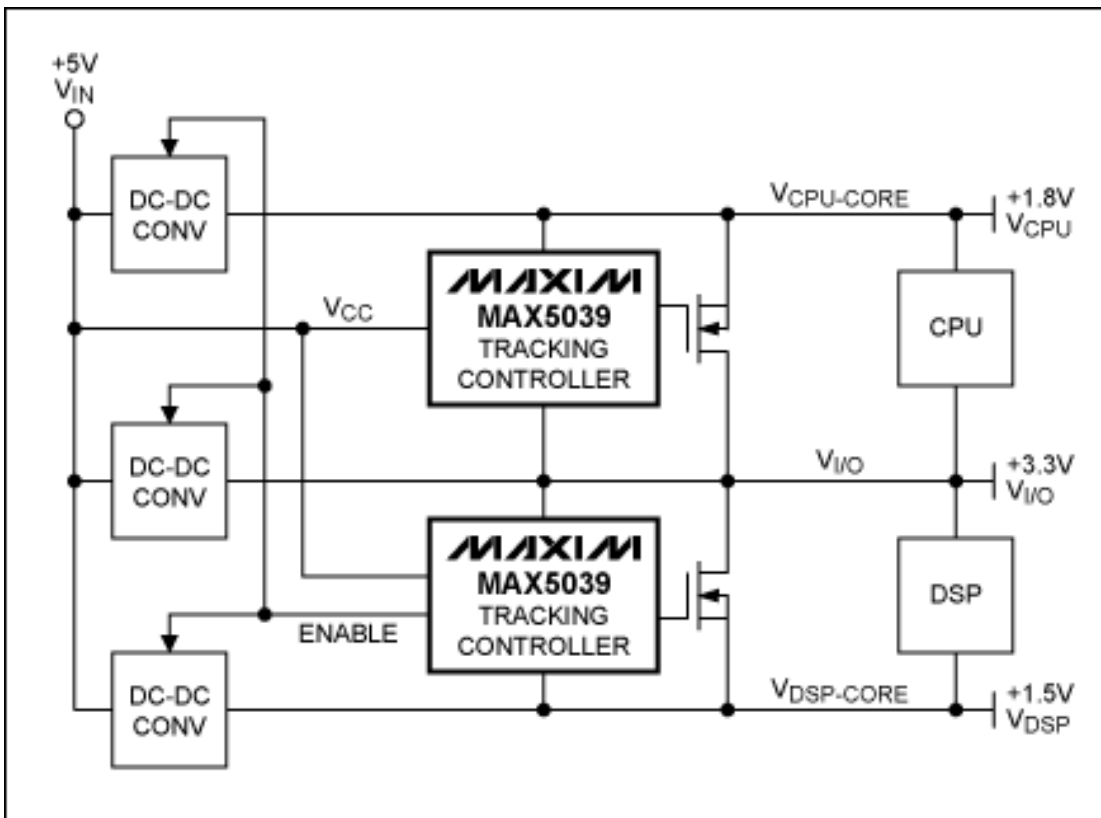

Figure 4. Multivoltage systems require multiple tracking controllers.

Configurable Voltage Tracker

In addition to tracking voltages, today's complex systems often require additional functions. Some of these functions include voltage monitoring, voltage sequencing along with tracking (mixed operation), and current monitoring. As the number of voltages continue to increase, the ability to find an adequate solution becomes more difficult as multiple devices are often necessary. In addition, many of these requirements may vary during the prototype development process, making it highly desirable to be capable of adjusting specific parameters as the system evolves. As a result, new generations of system management devices integrate many of these functions into a single device to reduce the number of components, provide more flexibility, and improve reliability. The MAX6876 system-management device, for example, can track or sequence numerous voltages (**Figure 5**). Because it is an EEPROM-configurable quad voltage tracker/sequencer, it adjusts multiple parameters including monitored thresholds, fault timing requirements, slew rates, and overcurrent limits.

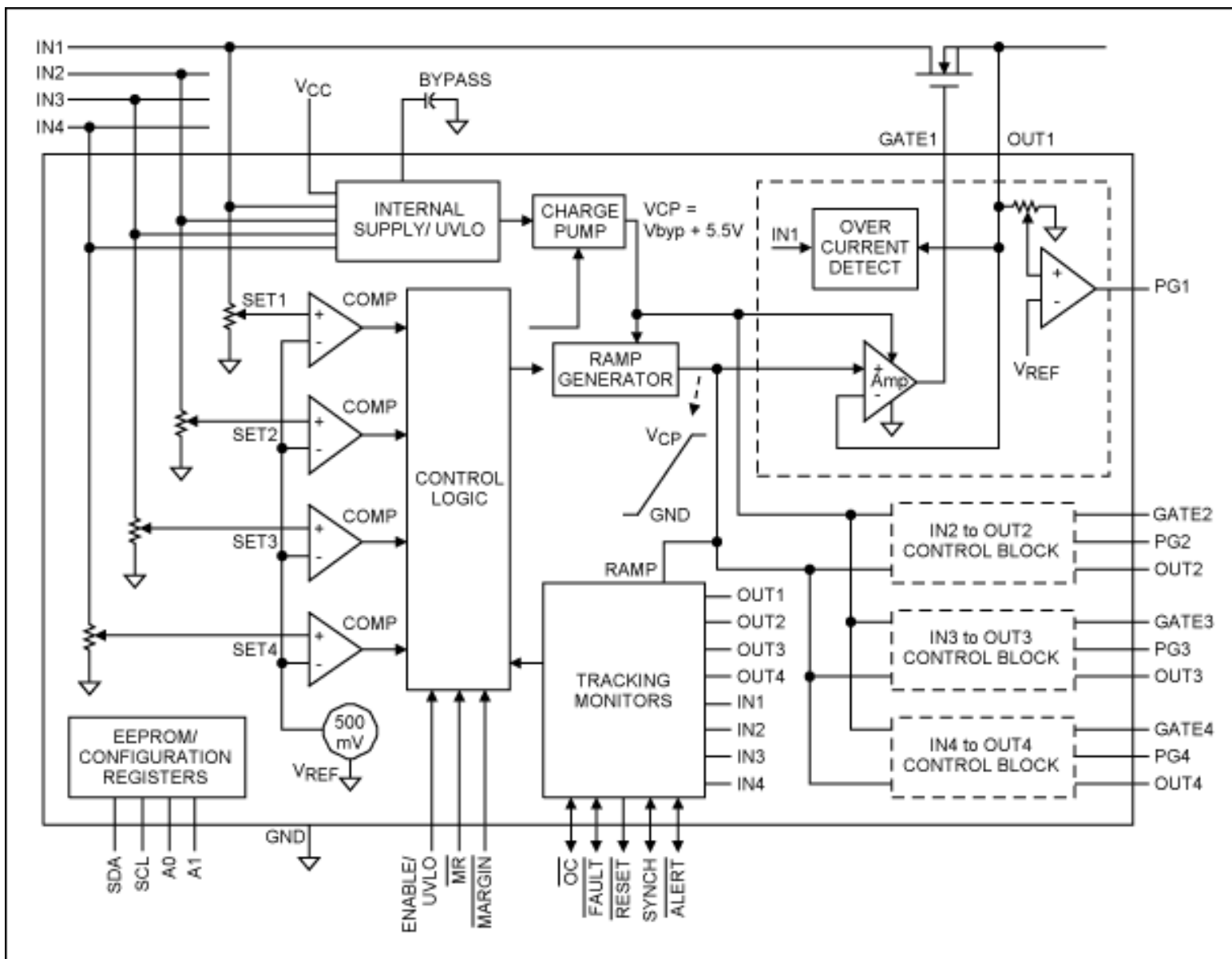

Figure 5. A programmable quad voltage tracker (MAX6876).

When the voltages power up, all external n-channel MOSFETs are off until every voltage reaches its specified level as set by configuring the internal EEPROM through an I²C interface. To ensure that the necessary voltages are available at all times, each level is monitored throughout the startup process, during normal system operation, and during a power-down or fault condition. If any voltage is absent, the device asserts a reset and tracks the power-down process.

Startup begins when all monitored voltages exceed their thresholds. To enhance the external MOSFETs, each gate voltage begins to increase (ramp up) simultaneously. The system monitors each MOSFET source and compares it to other voltages applied to the load. If any two voltages create a differential greater than 150mV, the gate associated with the higher voltage slows that voltage and allows the others to "catch up." If the others cannot catch up, the power-up process is aborted. The internal EEPROM can restart the power-up process by selecting the autoretry option, and it can also adjust the gate-drive slew rates.

If no problems arise during this initialization, the voltages track together until the lowest voltage is applied to the load. When this voltage is reached, the system allows the voltage ramp on each gate to increase until the next highest supply voltage turns on. This process continues until all voltages are powered up. Four independent, internal charge pumps add 5.5V to the input voltage to ensure a 5.5V gate-to-source enhancement of each MOSFET. This keeps drain-to-source resistances to a minimum. The use of logic-level FETs can further reduce loss.

To forestall any problems during a fault or a system shutdown, the voltages are made to track each other during power-down. The MAX6876 monitors for excessive current through the MOSFETs, and four MAX6876s can be synchronized to track up to 16 voltages.

Conclusion

The numerous methods for tracking voltages during power-up and power-down range from the simple approach of connecting the voltages through diodes, to complex techniques that use external circuitry or control the feedback path of a regulator. Such techniques can be configured for open-loop or closed-loop operation, according to the level of reliability required and the associated cost of implementing the functions. As systems become more complex, core voltages continue to fall, and power consumption continues to increase, the need for voltage tracking becomes more imperative.

A similar article appeared in the May 1, 2006 issue of *Planet Analog*.

Application Note 3811: www.maxim-ic.com/an3811

More Information

For technical support: www.maxim-ic.com/support

For samples: www.maxim-ic.com/samples

Other questions and comments: www.maxim-ic.com/contact

Automatic Updates

Would you like to be automatically notified when new application notes are published in your areas of interest? [Sign up for EE-Mail™](#).

Related Parts

MAX5039: [QuickView](#) -- [Full \(PDF\) Data Sheet](#) -- [Free Samples](#)

MAX6820: [QuickView](#) -- [Full \(PDF\) Data Sheet](#) -- [Free Samples](#)

MAX6876: [QuickView](#) -- [Full \(PDF\) Data Sheet](#) -- [Free Samples](#)

AN3811, AN 3811, APP3811, Appnote3811, Appnote 3811

Copyright © by Maxim Integrated Products

Additional legal notices: www.maxim-ic.com/legal