

APPLICATION NOTE 3810

## Trends in Op Amps Reflect an Advancing Electronics Industry

*Abstract: Operational amplifiers are fundamental building blocks in analog circuit design, and the combination of smaller size and improved performance has always been a desired goal. This application note highlights the direction in which op amps are headed, and the trade-offs that need to be overcome.*

### Introduction

In today's growing market for electronic devices, higher performance operational amplifiers are in constant demand. Higher bandwidth, lower power, and greater accuracy are a few of the major parameters that are needed for new products. Despite improvements in these specifications, however, the ideal op amp remains a myth; op-amp design continues to be a game of tradeoffs. Fortunately, most applications will have one parameter that is more critical than the rest, and compromises can be reached. The goal then is not to create the ideal op amp, but to create the best one for a particular application.

### Optimizing an Op Amp for Different Applications

With the increase in battery-powered products has come greater demand for op amps that consume less power. Op amps used in these portable applications must often operate from a lower—and usually single—positive supply voltage, while consuming less current. Customers' demand for lower current consumption can create quite a challenge for the designer, because some op amps are required to operate at higher frequencies or with lower noise, despite having to draw less current.

As these portable devices shrink, board real estate becomes an important factor. Thus the need for smaller packages increases. One of the older, more popular surface-mount packages is the *small outline* (SO) package, which is not so "small" when compared to some of the newer packages, such as the SOT23, SC70, or even the tiny chip-scale packages, such as the UCSP (**Figure 1**). The reduced parasitic inductance and capacitance of these smaller packages improves AC performance, but they often cause higher offset errors because their use places increased stress on the silicon die. Fortunately, these higher offsets can be reduced with skillful IC design.

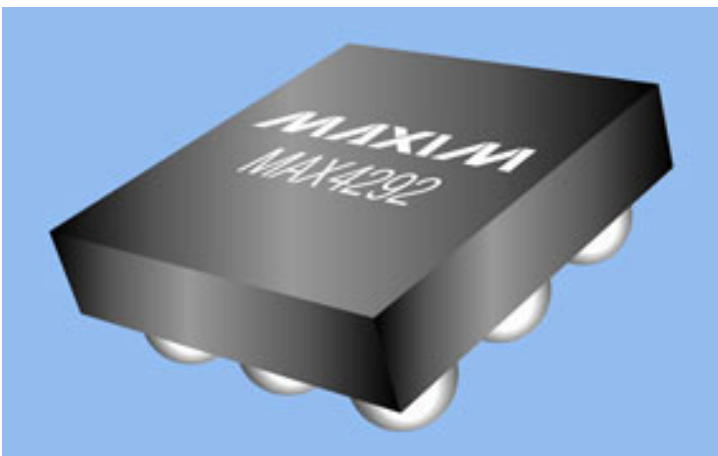

Figure 1. The MAX4292 is a dual, precision op amp in a tiny chip-scale (UCSP) package.

Improvements in process technology have aided the development of higher performance, lower cost op amps. Older op amps were fabricated using purely bipolar processes, but newer designs can employ any combination of several processes, including CMOS, BiCMOS, or complementary bipolar (CB). For op amps, CMOS is emerging as the dominant process from a cost standpoint, and the performance limitations that were once introduced by CMOS processes (i.e.,

noise) are slowly diminishing as the process technology improves. Higher performance devices typically require some combination of the various processes.

The standard op amp has been modified in different ways to suit different applications. Today, the designer has to choose among various op-amp types such as precision, instrumentation, current-sense, high-speed, and even audio and video. Improvements to the devices have become more application-specific.

Precision op amps generally do not provide high bandwidth, but the offset-voltage and offset-drift specifications are usually excellent. The guaranteed offset voltages can be as low as one microvolt. Autozeroing and chopper-stabilization techniques help to maintain these specifications over temperature by minimizing the effects of offset drift. Chopper-stabilized op amps typically include a nulling (or "chopper") amplifier in the signal path that continuously corrects for the inherent offset voltage of the op amp. Hence, one can achieve excellent offset-voltage specifications, even over temperature.

In addition to low offset voltages, lower supply-voltage operation increases the importance of rail-to-rail or Beyond-the-Rails™ input stages and rail-to-rail output stages. Rail-to-rail inputs allow the input voltage to range from negative to positive supplies, and Beyond-the-Rails inputs allow input voltages to exceed the rails of the device. More importantly, rail-to-rail outputs guarantee that the output will swing to within millivolts of either rail. This latter point is extremely important when trying to maximize every bit of the shrinking dynamic range of an op amp powered by a low voltage. Every bit of the input common-mode range and output-voltage range can become critical when dealing with supply voltages of 1V or less.

The rapid development of high-speed signal processing has increased the need for accurate, high-speed op amps with both single-ended and differential inputs. Many designers of new high-speed data converters are also focusing on lower power consumption and supply voltages. No matter the type of IC, speed and power are always tradeoffs. High-speed op amps can offer bandwidths up to the order of 1GHz, but such performance is difficult to achieve when lower supply voltages power the device. Today, one can easily get hundreds of megahertz with a 3V supply voltage, but IC manufacturers are still looking to push the thresholds to the extreme.

Op amps are also becoming specialized for audio and video applications. Audio amplifiers, unlike traditional precision amplifiers, are designed specifically for excellent dynamic performance within the audible frequency range. A new trend in audio amplifiers is the integration of charge pumps, as in Maxim's DirectDrive™ amplifiers, to allow operation from a single supply while eliminating the need for large DC-blocking capacitors (which are typically of the bulky electrolytic variety). With DirectDrive technology, the frequency response of the amplifier extends down to DC, improving the total harmonic-distortion performance at low frequencies. The DirectDrive approach reduces cost and board space—important benefits for the competitive portable-audio market (**Figure 2**).

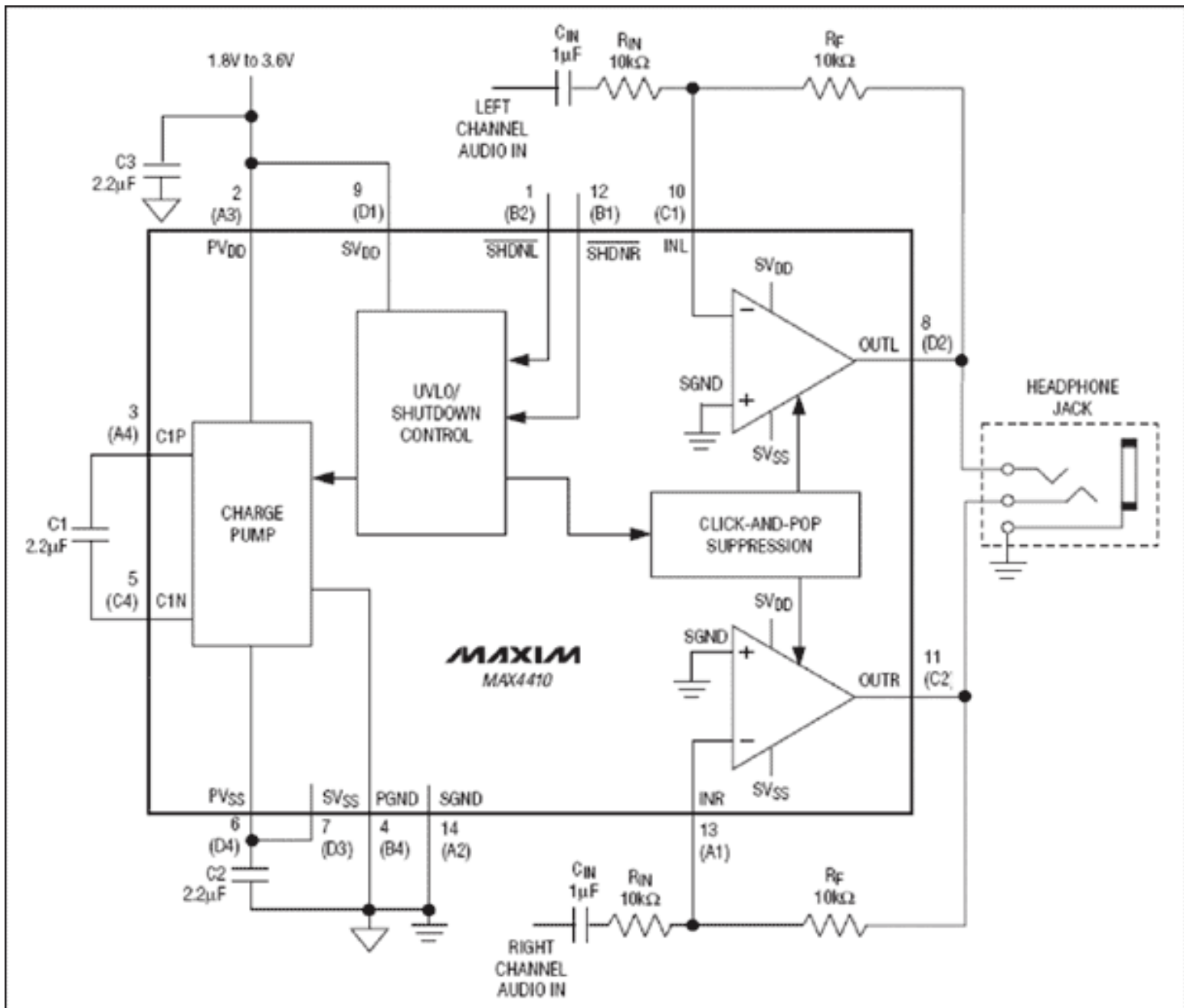

Figure 2. Single-supply headphone amplifier with an on-board charge pump eliminates the need for bulky DC-blocking capacitors.

Video amplifiers are becoming more specialized and increasingly integrated to handle the wide range of emerging video applications. Although products using dual  $\pm 5V$  supplies still exist, most newer video amplifiers are designed to operate from a single supply, while still driving one or two  $150\Omega$  loads. Due to the growing market for portable digital-video products, video amplifiers have begun migrating to lower supply voltages, such as  $3V$ , which presents yet another challenge for IC designers. In addition to single-supply operation, many video amplifiers include reconstruction filters for anti-aliasing or DAC-smoothing applications. Some video amplifiers even include black-level or back-porch clamps to eliminate external biasing or clamping circuitry. As with audio amplifiers, video amplifiers are also starting to use DirectDrive technology to allow amplifiers to accommodate the negative sync pulse in the video signal, thereby eliminating the need for external biasing.

## Conclusion

The op amp is one of the most fundamental building blocks used in analog-circuit design. As such, it must pace the rapidly advancing electronics industry. The universal demand for lower power and smaller packages has already inspired micropower op amps that are packaged in something barely visible to the naked eye: the UCSP package. Yet op amps continue to undergo further development. With steady improvements in design and process technologies,

manufacturers will continue to create op amps that meet the industry's growing requirements.

Beyond-the-Rails is a trademark of Maxim Integrated Products, Inc.  
DirectDrive is a registered trademark of Maxim Integrated Products, Inc.

---

Application Note 3810: [www.maxim-ic.com/an3810](http://www.maxim-ic.com/an3810)

#### **More Information**

For technical support: [www.maxim-ic.com/support](http://www.maxim-ic.com/support)

For samples: [www.maxim-ic.com/samples](http://www.maxim-ic.com/samples)

Other questions and comments: [www.maxim-ic.com/contact](http://www.maxim-ic.com/contact)

---

#### **Automatic Updates**

Would you like to be automatically notified when new application notes are published in your areas of interest? [Sign up for EE-Mail™](#).

AN3810, AN 3810, APP3810, Appnote3810, Appnote 3810

Copyright © by Maxim Integrated Products

Additional legal notices: [www.maxim-ic.com/legal](http://www.maxim-ic.com/legal)