



APPLICATION NOTE 3806

Performance Test for a Serializer and Deserializer Pair: MAX9247 and MAX9218

Abstract: High-speed serialized data connection has been widely used in video displays, digital camera sensing, and backplane data transmission in networks, servers, and 3G base stations. Maxim developed products for serial link transmitters and receivers. This application note demonstrates the performance of a typical serializer and deserializer (SerDes) pair (the MAX9247 and MAX9218) under various cable type, cable length, and data rate conditions. The resulting information is a good guide for applications that require high-speed, serialized data connection.

Introduction

Maxim's high-speed serializer and deserializer (SerDes) products have been used in automotive, networking, server, and 3G base stations for video, image, and data transmissions. The MAX9247 serializer and the MAX9218 deserializer form a typical pair of a single LVDS link with embedded clock. The highest serial-link data rate, which the pair can reach, is up to 800Mbps.

This application note demonstrates the performance of this data transceiver link based on different cable types, cable lengths, and data rates. The article also shows the performance improvements that result from Maxim's proprietary pre-emphasis function and line equalizer. To meet the harsh environment in an automotive application, this SerDes pair is also tested in the -40°C to +105°C temperature range.

Test Setup

The test setup consists of an Agilent ParBERT 81250 tester, TDS784C 1GHz digital scope, TEK P6247 Differential probe, and the MAX9217/MAX9218 EV kit board. The Agilent 81250 is a parallel bit error rate tester (BERT). The components are connected as shown in the following illustration (**Figure 1**).

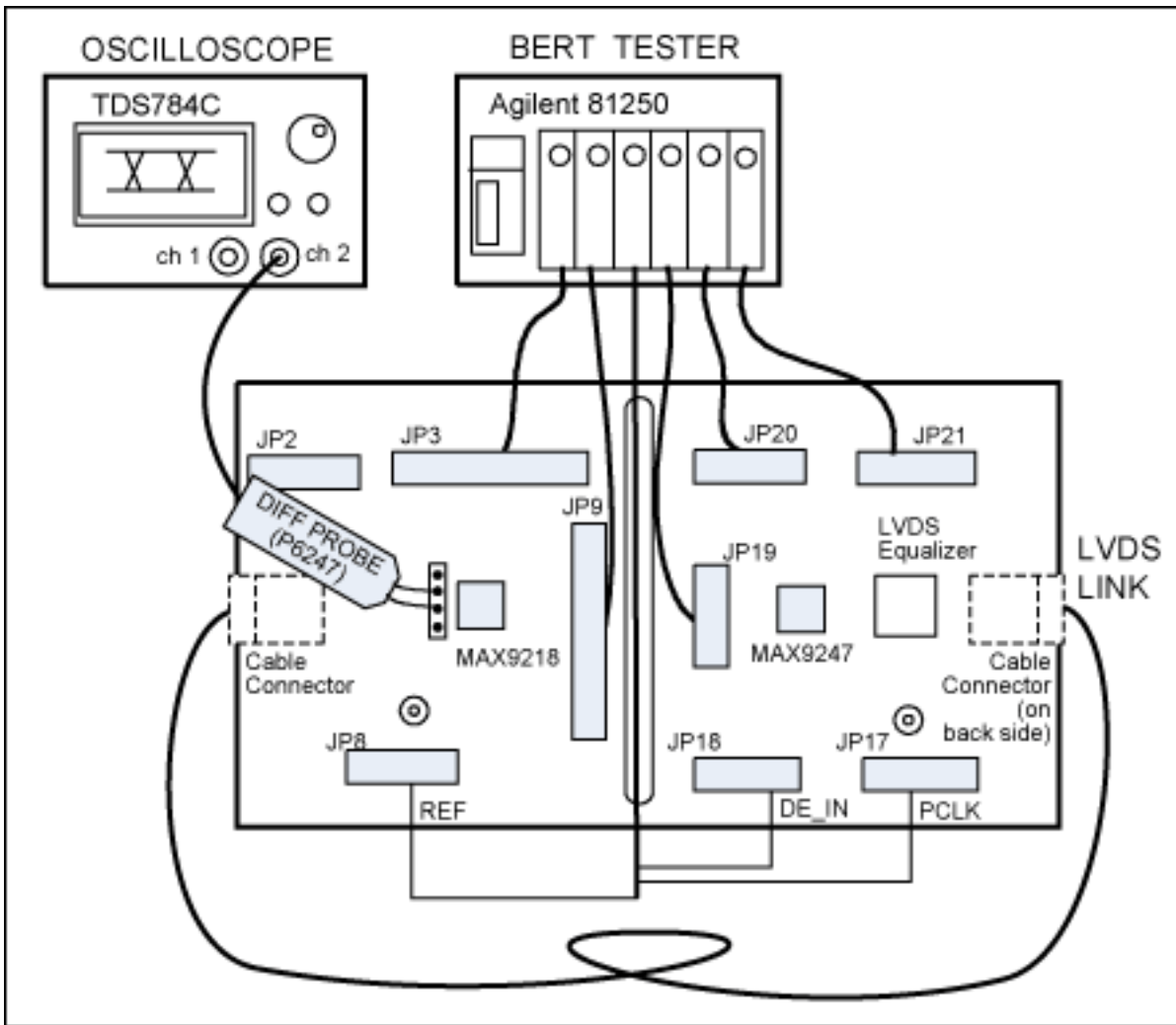

Figure 1. Performance test setup of the MAX9247 and MAX9218.

The MAX9247 has 27 bits of parallel data inputs in which 18 bits are for RGB video data inputs and 9 bits are for controlling data inputs. The data rate at the LVDS serialized link is 20 times the parallel data rate, including 2 overhead bits. The first 9 output channels of the Agilent 81250 are connected to the first 9 RGB inputs (RGB_IN0 to RGB_IN8). The inversed outputs of the first 9 channels are connected to the remaining 9 RGB inputs (RGB_IN9 to RGB_IN17). The BERT is only implemented on the RGB data. The data sequence on each of the ParBERT's output channels is an independently generated pseudo-random bit stream with a nonrepeating length of 2^{1492} . The RGB data sequence is 1370 bits long. After the 1370 bits, a 20-bit interval is added for the control period. All the control bits (CNTL_IN0 to CNTL_8) are always set to be zeros. **Figure 2** shows the data structure. The 1390-bit parallel data pattern is repeated during the test. The signal DE_IN alternates the RGB data period and the control period.

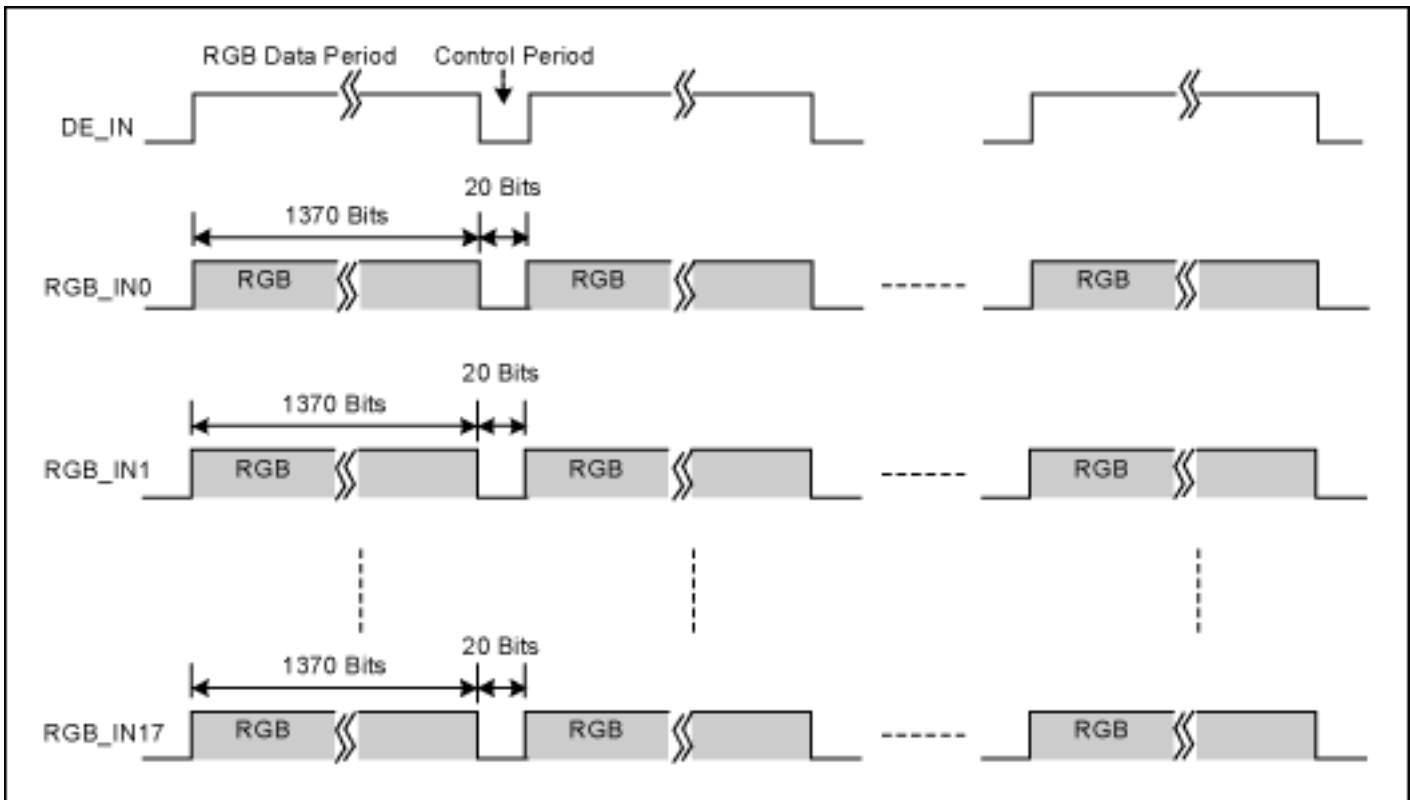

Figure 2. Sequence structure for the test data.

Test Conditions and Measurement Results

We tested three twist-pair cables, as listed in the following table.

Table 1. Cable Types Under Test

Manufacturer	Part Number	Length(M)	Comments
NISSEI	SIODIC F-2WME, AWG26	10, 20, 30	Shielded
	SIODIC F-2WME, AWG28	10, 20, 30	
General Cable	CAT5E, AWG24	10, 20, 30	Unshielded
JAE	MX38	20	Shielded

To test the performance of the SerDes pair vs. cable length and data rate, we observe the bit error rate (BER) for each cable length and record the highest parallel data rate under which there is no bit error in ten minutes. The data rate increment is 1Mbps. We use this method to measure the performance because of two observations about the LVDS SerDes transceiver: first, if there is no error within ten minutes, there probably will be no error for a few hours; second, when error bits are observed within the ten minutes even at a very low rate, a slight increase of the data rate (<0.5Mbps) will cause the loss-lock of the DE_OUT signal at the deserializer. Consequently, our approach is a reasonable trade-off between the test time and the measurement reliability. Our hypothesis is, therefore, that the link BER is less than 10^{-10} or 10^{-11} when no bit error occurs within ten minutes at a certain data rate. Statistically, we can calculate the confidence level of this hypothesis using **Equation 1**:

$$CL (\text{Confidence Level}) = (1 - (1 - p)^N) \times 100\% \quad \text{Eq. 01}$$

where N is the number of bits transmitted through the serial link in the observation period (e.g., ten minutes) and p is the hypothesized BER. **Table 2** provides the CL for different data rates.

Table 2. Confidence Level vs. Data Rates in a Ten-Minute Observation

Parallel Data Rate(Mbps)	Number, N, of Bits Transmitted by the Serial Link in Ten Minutes	Confidence Level of p	
		BER < 10 ⁻¹⁰	BER < 10 ⁻¹¹
10	12 x 10 ¹⁰	> 99.999%	69.88%
20	24 x 10 ¹⁰	> 99.999%	90.92%
30	36 x 10 ¹⁰	> 99.999%	97.27%
40	48 x 10 ¹⁰	> 99.999%	99.18%

Test Results

Table 3 shows the performance results which are obtained over various cable types, cable lengths, and data rates, and with the pre-emphasis function and the LVDS equalizer on or off. The pre-emphasis function is integrated in the MAX9247 and can be enabled by setting the jumper JP15 to 'High' on the EV board. The proprietary LVDS equalizer is mounted on the MAX9247's LVDS output, as shown in Figure 1. For details on implementing the equalizer, please contact Maxim Application Support. All the data in Table 3 were generated at room temperature. Test results with the 30m NISSEI AWG26 cable over the extended temperature range are shown in **Table 4**.

Table 3. Reliable Data Rates for a SerDes Transceiver Tested Under Various Conditions

Cable Type	Pre-Emphasis	LVDS Link Equalizer	Maximum Reliable Serial Data Rate (SDR)					
			Cable Length					
			10m		20m		30m	
			PCLK (MHz)	SDR (Mbps)	PCLK (MHz)	SDR (Mbps)	PCLK (MHz)	SDR (Mbps)
NISSEI AWG26	Off	Off	34	612	25	450	15	270
	On	Off	40	720	27	486	17	306
	Off	On	38	684	34	612	30	540
	On	On	43	774	39	702	35	630
NISSEI AWG28	Off	Off	33	594	16	288	8	144
	On	Off	36	648	23	414	10	180
	Off	On	35	630	33	594	23	414
	On	On	41	738	37	666	28	504
General Cable CAT5e	Off	Off	38	684	26	468	16	288
	On	Off	42	756	28	504	18	324
	Off	On	38	684	35	630	32	576
	On	On	44	792	42	756	36	648
JAE MX38	Off	Off			16	288		
	On	Off			24	432		
	Off	On			35	630		
	On	On			40	720		

Table 4. Reliable Data Rates for a SerDes Transceiver Operating Over the Extended Temperature Range(*)

Cable Type	Maximum Reliable Serial Data Rate (SDR)					
	Temperature					
	-40°C		25°C		105°C	
	PCLK (MHz)	SDR (Mbps)	PCLK (MHz)	SDR (Mbps)	PCLK (MHz)	SDR (Mbps)
NISSEI AGW26, 30m	36	648	35	630	31	558

*Note that in this test, the pre-emphasis and LVDS equalizer are both on.

The following eye diagrams were recorded at the deserializer's LVDS input port. These plots show the deserializer's data recovery capability under the distorted bit symbols. We can also see the significant improvement by the LVDS link equalizer on the eye diagrams.

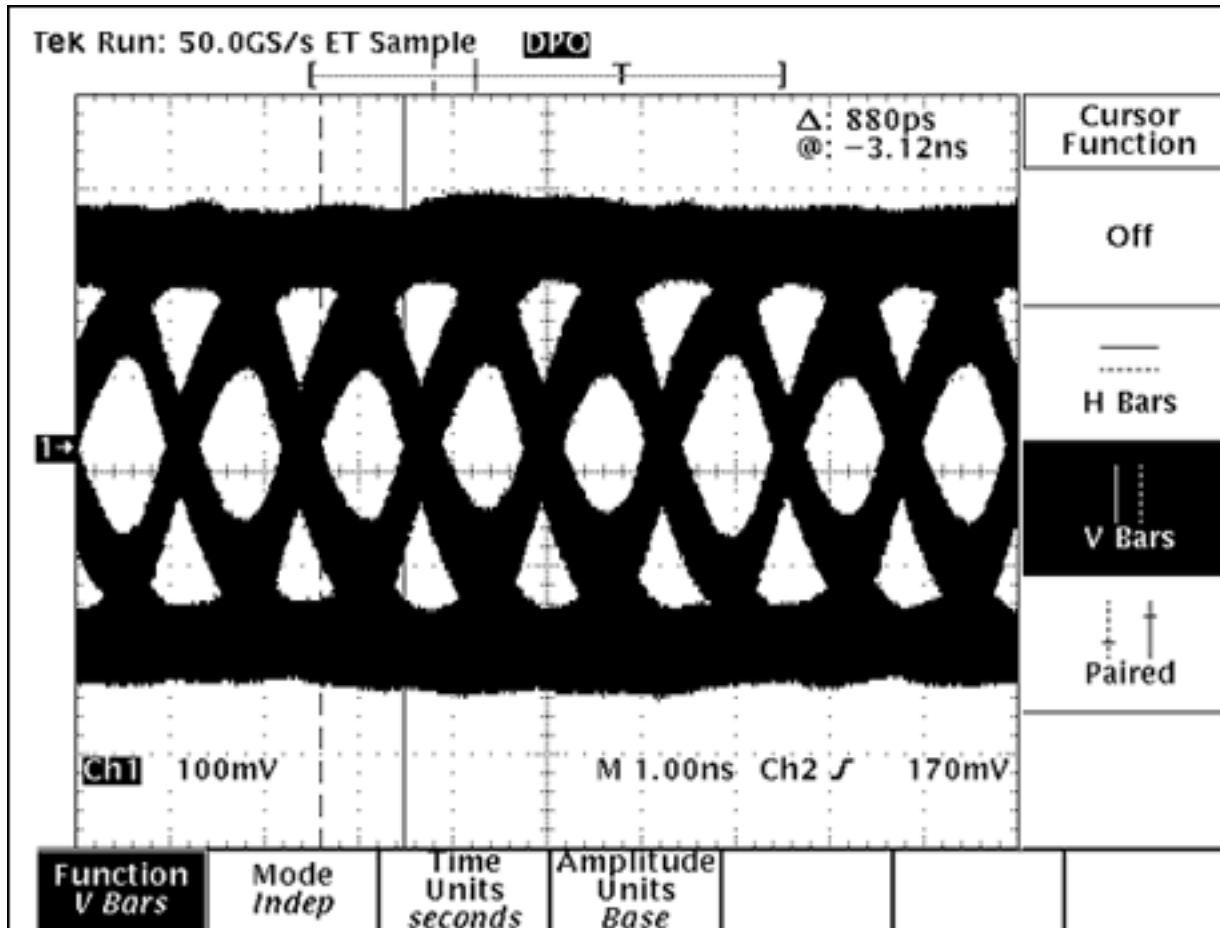

Figure 3. NISSEI AWG26, 20m at 702Mbps with pre-emphasis and equalizer.

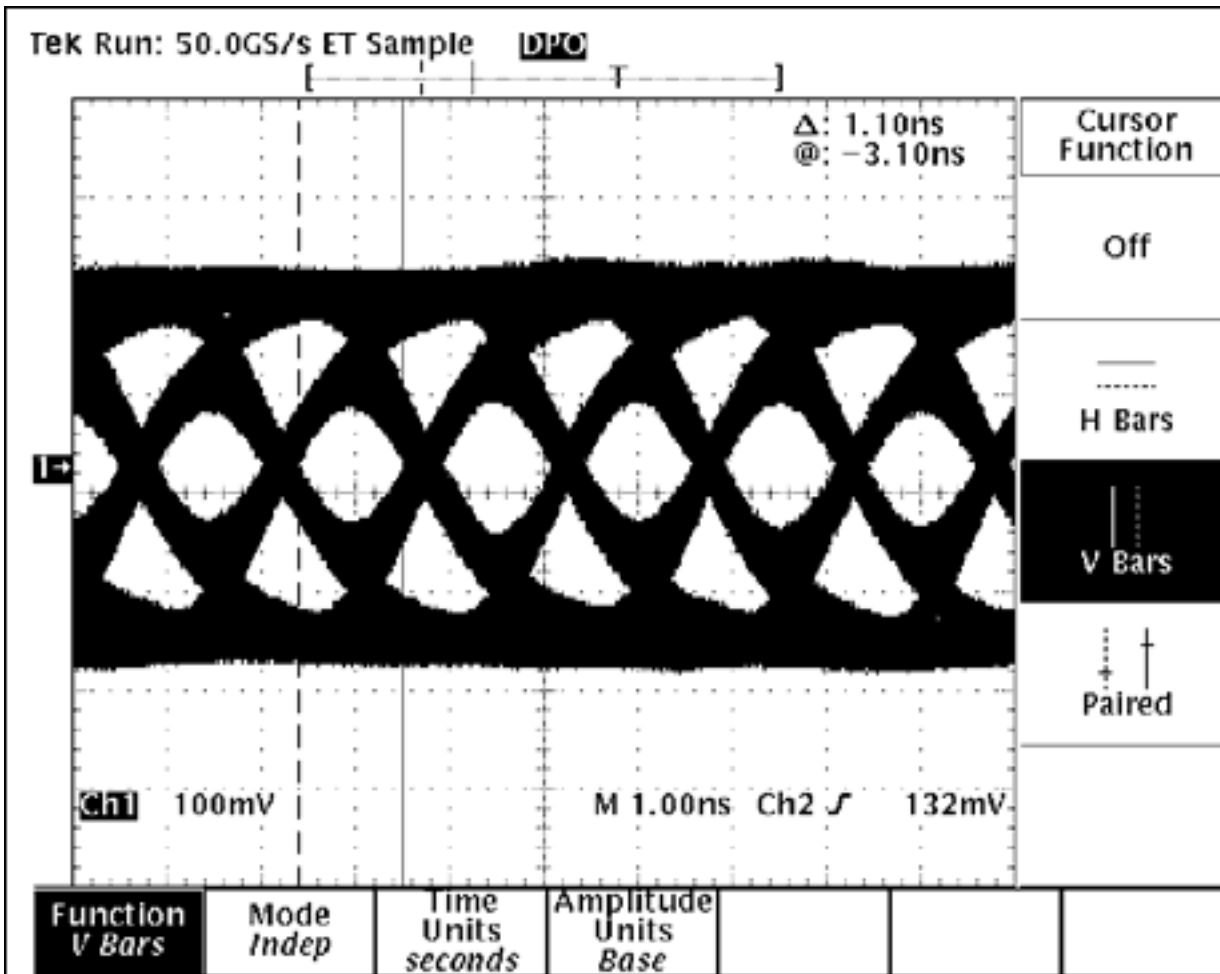

Figure 4. NISSEI AWG26, 30m at 630Mbps with pre-emphasis and equalizer.

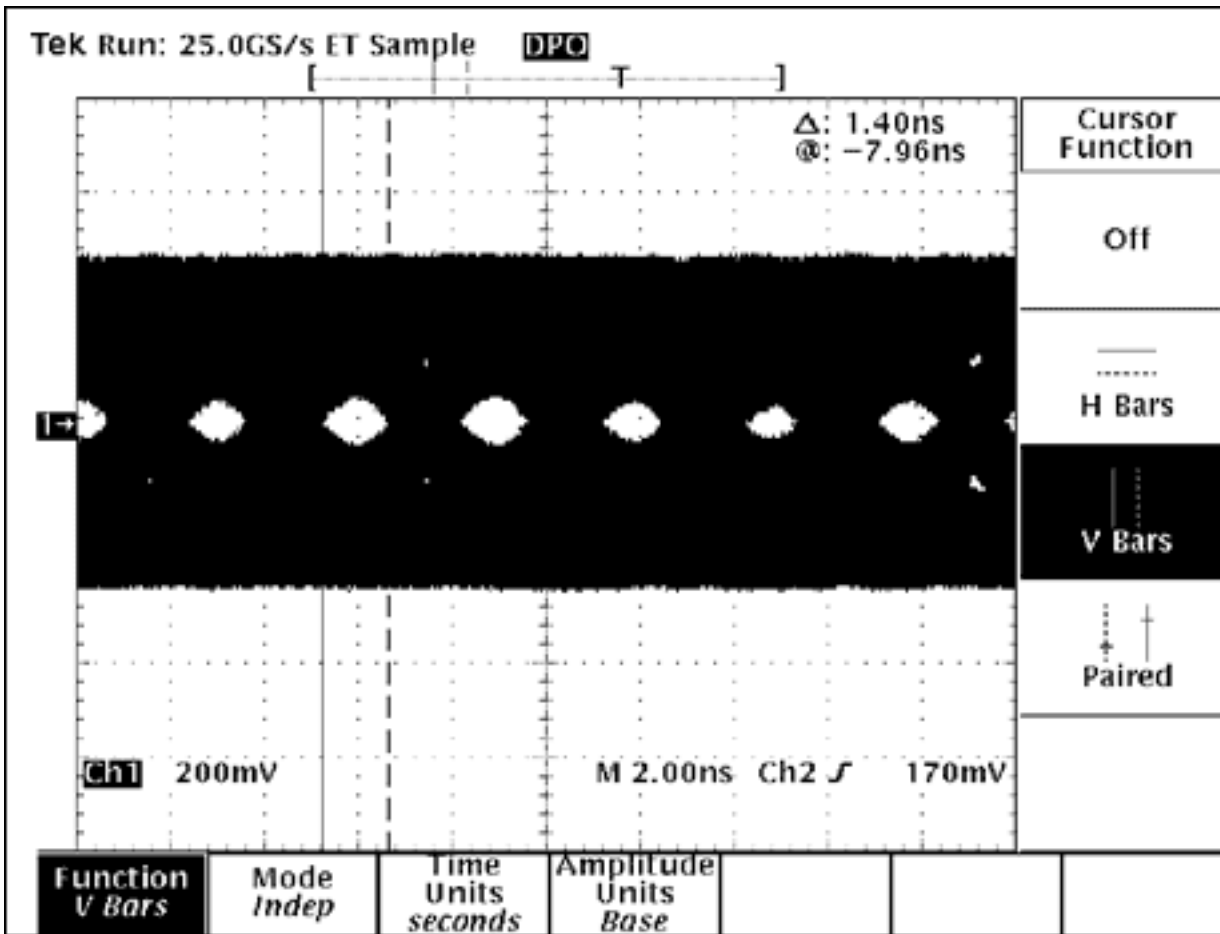

Figure 5. NISSEI AWG26, 30m at 306Mbps with pre-emphasis.

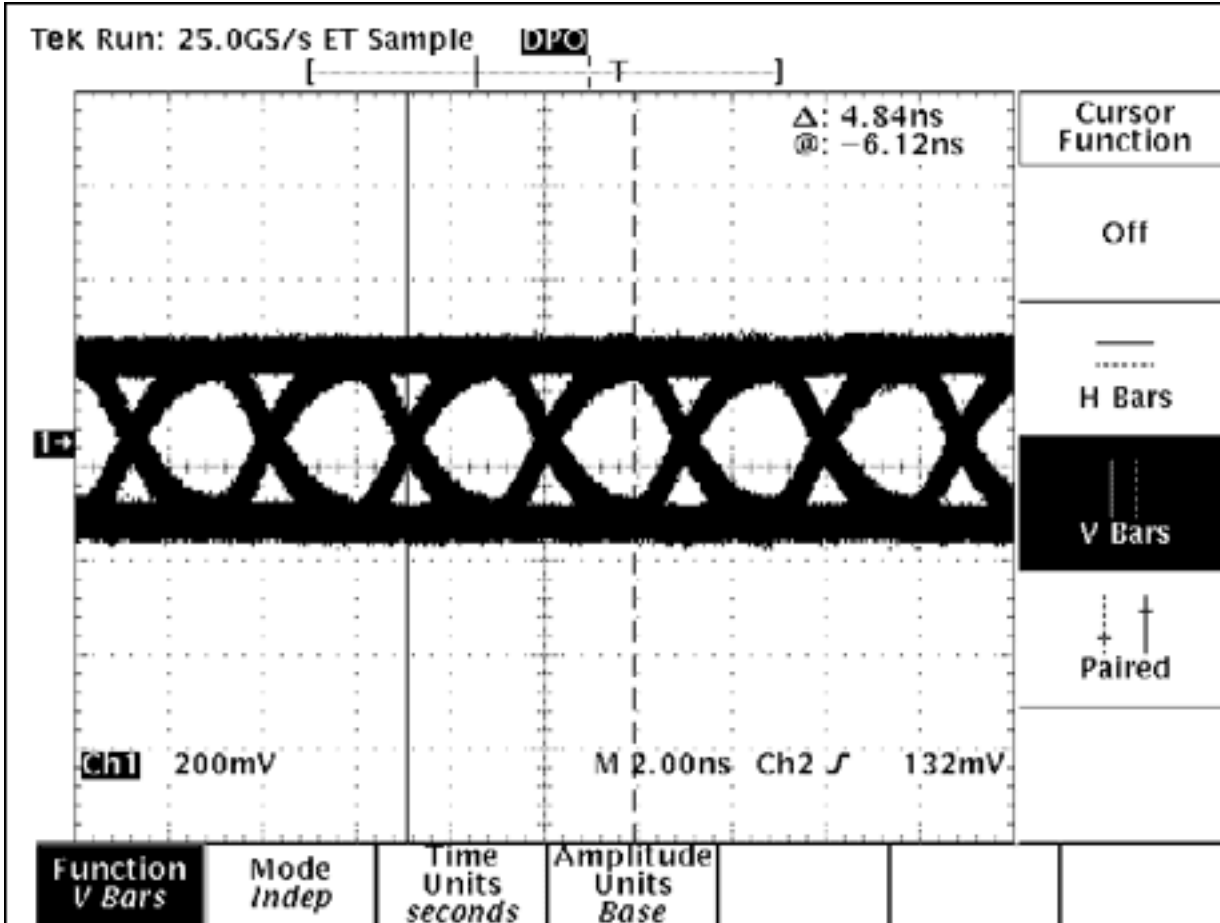

Figure 6. NISSEI AWG26, 30m at 306Mbps with pre-emphasis and equalizer.

Summary

From the results shown in Tables 3 and 4, we can make the following observations.

- Although CAT5E unshielded cable has the better performance than the other two types of cable, it could have EMI issues in applications.
- Pre-emphasis and LVDS equalization help the link performance. Pre-emphasis gives bigger boost for a short cable and the later provides more efficient improvement for a longer cable. For the 30m cables, the equalizer could double the data rates.
- The performance variation in the extended temperature range is relatively small.
- The cable wire gauge could limit the performance. A wire gauge larger than AWG28 is recommended.

Reference

1. [Maxim High-Speed Interconnect Design Guide](#)
2. [MAX9247 data sheet](#)
3. [MAX9218 data sheet](#)

Application Note 3806: www.maxim-ic.com/an3806

More Information

For technical support: www.maxim-ic.com/support

For samples: www.maxim-ic.com/samples

Other questions and comments: www.maxim-ic.com/contact

Automatic Updates

Would you like to be automatically notified when new application notes are published in your areas of interest?

[Sign up for EE-Mail™.](#)

Related Parts

MAX9217: [QuickView](#) -- [Full \(PDF\) Data Sheet](#) -- [Free Samples](#)

MAX9218: [QuickView](#) -- [Full \(PDF\) Data Sheet](#) -- [Free Samples](#)

MAX9247: [QuickView](#) -- [Full \(PDF\) Data Sheet](#)

MAX9248: [QuickView](#) -- [Full \(PDF\) Data Sheet](#)

MAX9250: [QuickView](#) -- [Full \(PDF\) Data Sheet](#)

AN3806, AN 3806, APP3806, Appnote3806, Appnote 3806

Copyright © by Maxim Integrated Products

Additional legal notices: www.maxim-ic.com/legal