



[Maxim](#) > [App Notes](#) > [COMMUNICATIONS CIRCUITS](#) [HIGH-SPEED INTERCONNECT](#)
[HOT-SWAP AND POWER SWITCHING CIRCUITS](#) [MISCELLANEOUS CIRCUITS](#) [PROTECTION AND ISOLATION](#)

Keywords: AMR, Automatic Meter Reading, RS485, Power Meter Application, Meter Interface, Isolated RS485, Power Meter Interface. Apr 19, 2006

APPLICATION NOTE 3776

Considerations for Selecting an RS-485 Transceiver in Electronic Power Meters

Abstract: Automatic meter reading technology provides a communication port to power meters, allowing them to be read electronically and remotely. This application note discusses the various features of Maxim's RS-485 transceivers that make them well suited for communication ports in electronic power meters.

Automatic meter reading is becoming increasingly popular in electronic power meters. This technology provides a communications port to the power meter, allowing it to be read electronically and, in most cases, remotely. This allows power utilities to save both money and time. The key to making this technology work is to ensure the communications link is both safe and robust. RS-485 is a simple, cheap, reliable communications specification that is well suited for automatic meter reading. The following article discusses the numerous features of Maxim's RS-485 transceivers that make them ideal for electronic power meters.

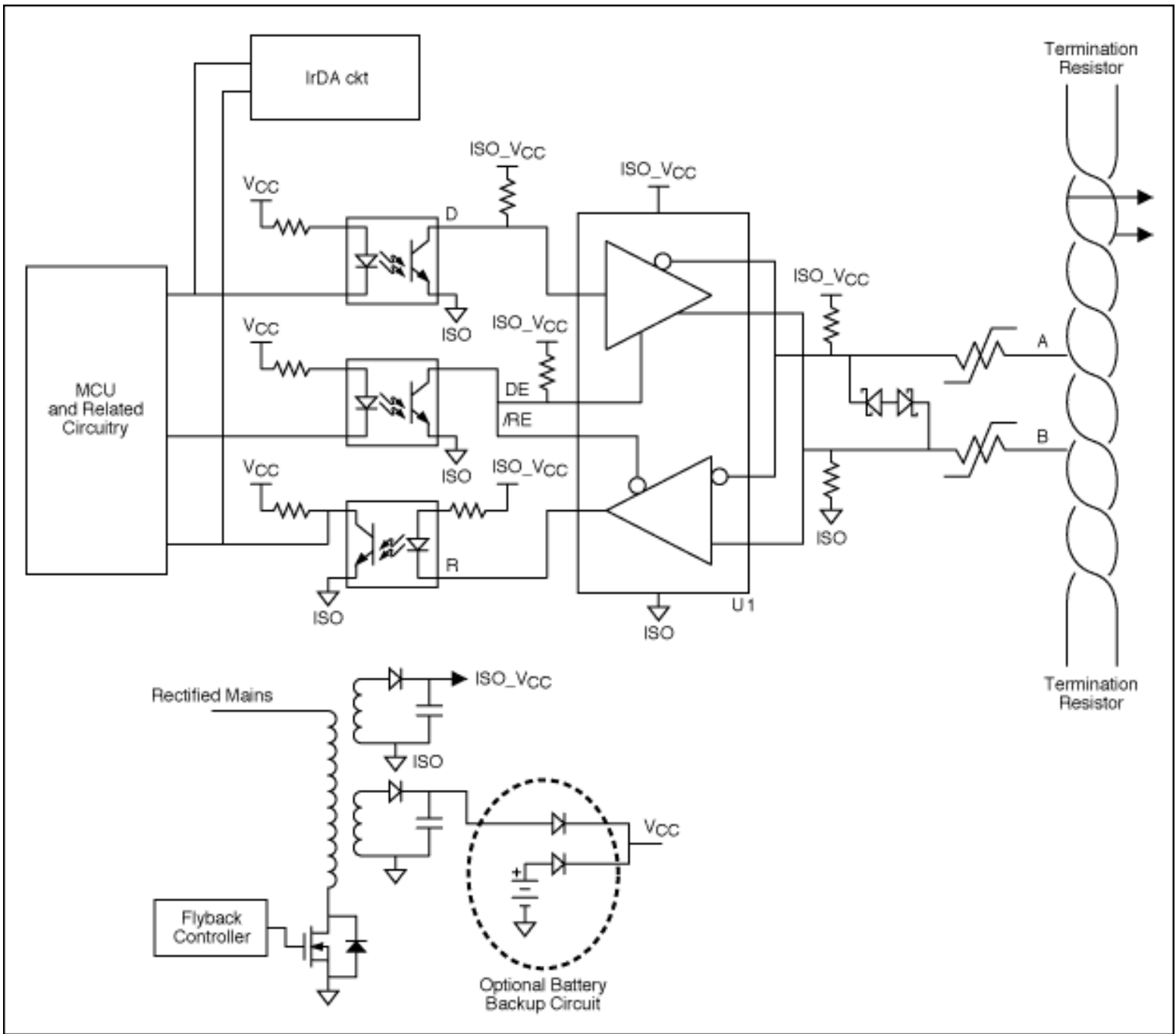

Figure 1. An example block diagram of an electronic power meter with an RS-485 port.

Figure 1 shows an example block diagram of an electronic power meter using an RS-485 port. The port is electrically isolated from the MCU and analog front-end by the use of optocouplers and a transformer. This isolation provides protection and robustness against electrical surges on the RS-485 lines.

The pullup and pulldown resistors on the A and B lines serve to define the state of the receiver in the event of a cable disconnect. Using these resistors, the receiver output is always high when the cable is disconnected, which can have many advantages. In the Figure 1 system, the IrDA circuit has an open-drain output. Consider what would happen if the RS-485 transceiver were to incorrectly pull the line low when the cable becomes disconnected. In this case, the optocoupler's output transistor would be on and would hold the bus low, preventing any communication between the open-drain IrDA module and the MCU. By guaranteeing a high output on cable disconnects, the system can use other open-drain devices on the same UART bus.

The PTC and TVS combine to provide differential-mode overvoltage protection in the event that one of the RS-485 wires gets shorted to the main power line (for example, 220VAC).

The isolated circuitry is powered by an additional winding on the flyback transformer. In the Figure 1 diagram, the flyback has two outputs: the first is for powering the MCU and analog front-end. The second is electrically isolated and provides power to the RS-485 port. Observe that if a battery backup is used with the flyback power supply shown above, it would

be effectively "diode OR-ed" in with the supply for the MCU (V_{CC} in the diagram). This means that the isolated_ V_{CC} would not be present when operating from battery. Therefore, the RS-485 circuit is not "on", so the meter cannot be communicated with during power outages and has no way to tell anyone that power has gone out.

The following are features of Maxim's RS-485 transceivers that can help improve/simplify the design of the RS-485 port electronic power meters. For more information on devices that include all these features, refer to the [MAX3070E](#) (3.3V) or [MAX13085E](#) (5V) data sheet.

Fail-Safe The RS-485 standard defines the threshold for the high and low signal to be $\pm 200\text{mV}$, but leaves the range between these levels as indeterminate. This presents problems under three conditions:

1. All the transmitters on the bus are disabled and therefore high impedance. This means the differential voltage between the receiver inputs is 0V due to the termination resistors on the bus.
2. There is a short circuit between the RS-485 wires. Again, the differential voltage between the wires is 0V.
3. There is an open circuit, or the power meter is disconnected. Again, the differential voltage is 0V because the transceiver itself has a high-impedance resistance between the inputs, forcing it to 0V.

Under all three conditions, the differential voltage is 0V. Unfortunately, the RS-485 specification defines 0V as an indeterminate voltage. This means the output of the receiver could either be high, low, or worse—it could oscillate between the two. Maxim's fail-safe receivers solve this problem by specifying the receive threshold between -50mV and -200mV. This is a tighter threshold than specified by the RS-485, and is therefore compliant. This is an advantage, because now the 0V differential voltage is defined as a known state, thus eliminating the problems caused by the three conditions listed above. This allows the power meter hardware designer to remove the two bias resistors shown in Figure 1.

Slew-Rate Limiting Because the data rates for most power-meter applications are in the 1kbps to 19.2kbps range, fast edge rates are unnecessary and only serve to generate unwanted radiated emissions. By controlling the edge rates of the driver in an RS-485 transceiver, the emissions at higher frequencies can be reduced. Lower slew rates also reduce data errors due to imperfect terminations and stubs, etc. (see **Figures 2 and 3**).

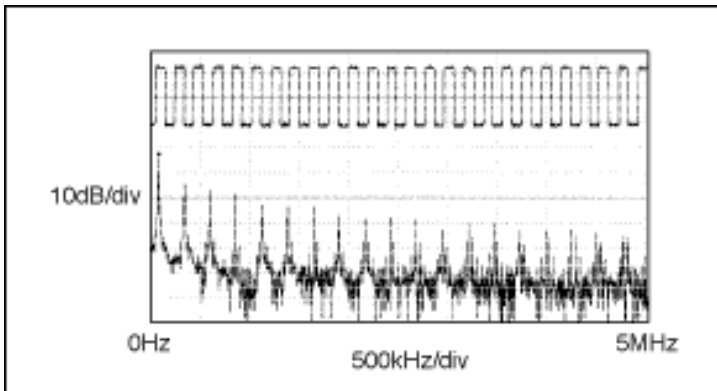

Figure 2. The driver output waveform and FFT plot of the MAX3485E/MAX3490E/MAX3491E transmitting a 125kHz signal.

The MAX3485E/MAX3490E/MAX3491E are not slew-rate limited and can therefore support higher data rates. However, the faster edges necessary for the higher data rates generate larger, higher frequency harmonics. These harmonics can increase radiated EMI and are less tolerant of imperfect terminations.

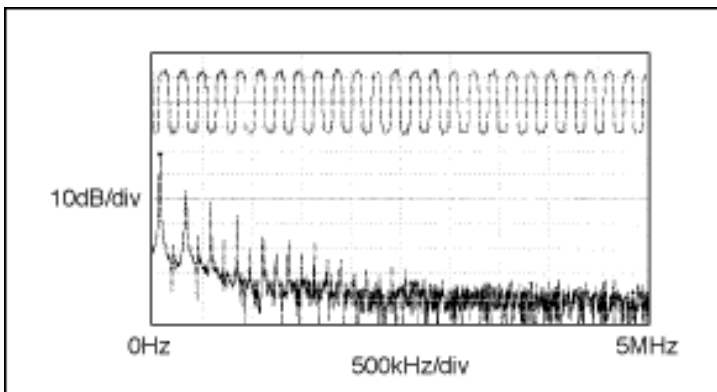

Figure 3. The driver output waveform and FFT plot of MAX3483E/MAX3488E transmitting a 125kHz signal.

The MAX3483E and MAX3488E are slew-rate limited and therefore have reduced maximum data rates of 250kbps or less. This is usually more than adequate for power meter applications. The reduced slew rates get lower as the frequency

harmonics become higher. This reduces EMI and imperfect termination issues.

Hot-Swap In multidrop systems, such as RS-485, it is important that only a single transmitter is enabled and transmitting. If two or more transmitters are enabled, there will be bus contention and therefore data errors. A robust system is able to tolerate a certain amount of data errors using software, but the hardware designer is still responsible for minimizing these errors in the first place. Maxim's hot-swap features are designed to address two common situations where there can be unintentional bus contentions:

1. A transceiver is initially powered up on an already active bus.
2. A transceiver is on a card that is hot plugged into an already active system.

Under both these conditions, the microcontroller (μC) driving the RS-485 transceiver will be going through a reset sequence. A significant number of μC s bring their I/O pins up tristated. Once the software code has had time to run, the microprocessor pins will ultimately be configured to their appropriate state. It is the time between initial power up and when the pins are properly configured that can cause problems. The primary concern is that the driver enable (DE) pin of the RS-485 transceiver will "see" an unintentional logic-level high. This occurs because the tristated pins will be pulled high due to noise or leakage currents.

Maxim's hot-swap feature solves this problem by using a two-step sequence. During the first $10\mu\text{s}$, the RS-485 transceiver is powered up, and a strong pulldown of $600\mu\text{A}$ through a $5\text{k}\Omega$ resistor is used to pull the DE pin low. A strong pulldown is used to discharge any capacitance on the DE pin. After $10\mu\text{s}$, a $100\mu\text{A}$ pulldown is used to maintain the logic-level low against leakage currents and noise. This $100\mu\text{A}$ pulldown current remains active until the DE pin is pulled high by an external source. Once the pin is high, the $100\mu\text{A}$ current source is disabled and the RS-485 transceiver operates normally (see **Figure 4**). This feature ensures that the transmitter on the RS-485 transceiver is tristated, preventing any unintentional bus contention.

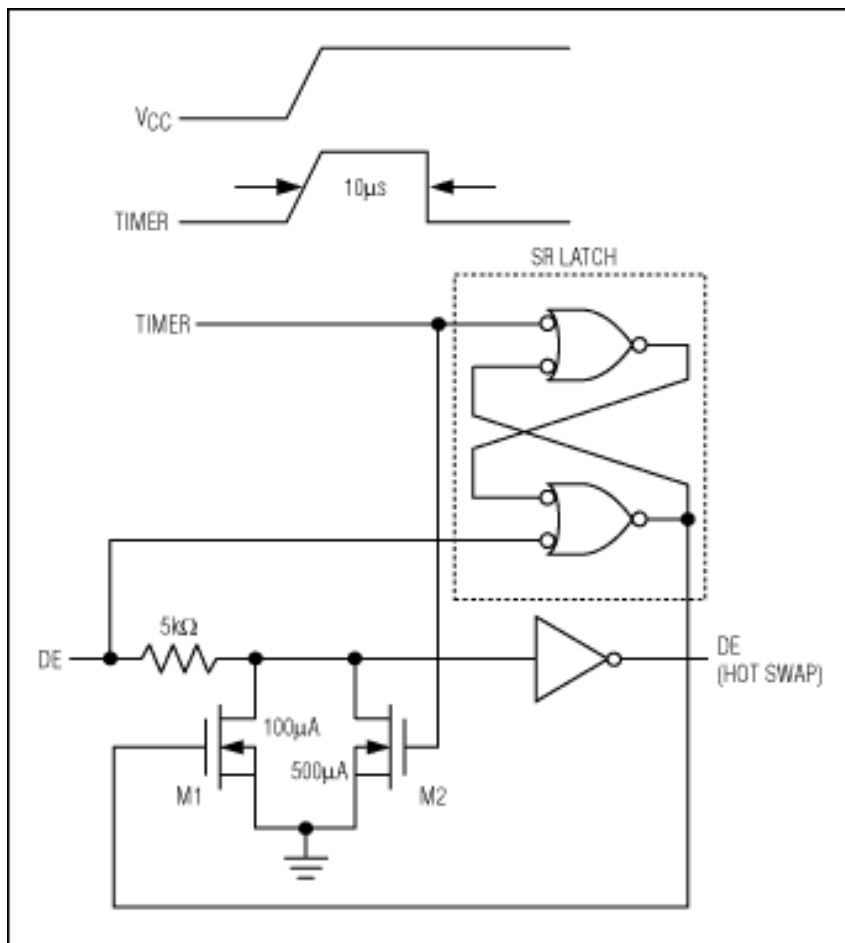

Figure 4. A simplified block diagram of Maxim's hot-swap circuitry on the DE pin.

Extended ESD Protection ESD is a problem for all semiconductor devices, and RS-485 transceivers are no different. Maxim products designated with an "E" include extended ESD which, in the case of the MAX3070E and MAX13085E, is $\pm 15\text{kV}$ using the Human Body Model (HBM).

Isolation The MAX3535 is a monolithic, isolated, 3.3V or 5V, self-powered RS-485 transceiver. It includes capacitive isolation, integrates the RS-485 transceivers, and uses an internal H-bridge driver with an external "off-the-shelf"

Would you like to be automatically notified when new application notes are published in your areas of interest? [Sign up for EE-Mail™.](#)

Related Parts

MAX13082E: [QuickView](#) -- [Full \(PDF\) Data Sheet](#) -- [Free Samples](#)

MAX13085E: [QuickView](#) -- [Full \(PDF\) Data Sheet](#) -- [Free Samples](#)

MAX3070E: [QuickView](#) -- [Full \(PDF\) Data Sheet](#) -- [Free Samples](#)

MAX3075E: [QuickView](#) -- [Full \(PDF\) Data Sheet](#) -- [Free Samples](#)

MAX3535E: [QuickView](#) -- [Full \(PDF\) Data Sheet](#)

AN3776, AN 3776, APP3776, Appnote3776, Appnote 3776

Copyright © by Maxim Integrated Products

Additional legal notices: www.maxim-ic.com/legal