



APPLICATION NOTE 3763

Measuring and Improving Return Loss on the DS317x and DS318x T3/E3/STS-1 LIUs

Abstract: This application note describes how to measure and improve the return loss on the DS317x and DS318x LIU transceivers. Improvements to standard test setup yield a return loss that meets industry-standard specifications for T3/E3 transceivers and ATM/Packet PHYs with a built-in LIU.

Introduction

This application note describes how to measure and improve the return loss on the DS317x and DS318x T3/E3 transceivers. Return loss is defined, and the return-loss specifications required by industry standards are shown. Return loss is then measured, first with a standard test setup and again with an adjusted, improved setup. Final test data show that the suggested design improvements will produce a return loss that meets industry specifications.

This application note applies to the following products.

T3/E3 Transceivers	ATM/Packet PHYs with Built-In LIU
DS3171	DS3181
DS3172	DS3182
DS3173	DS3183
DS3174	DS3184

Return Loss Defined

When a high-speed signal reaches the end of a imperfectly terminated transmission line, that transmission line will reflect a portion of the signal energy back toward the transmitter. This reflected signal mixes with the original signal and distorts it. As a result, it is more difficult for the LIU receiver to correctly recover clock and data.

Return loss is the ratio (expressed in dB) of the power of the original signal vs. the power of the reflected signal. In simple terms, return loss indicates the relative size of the reflected signal and, therefore, how perfectly or imperfectly the transmission line is terminated. If the measured return loss of an LIU card is 20dB at a given frequency, then the reflected signal has 20dB less power than the original signal at that frequency.

Return Loss Requirements

Both ITU G.703 and ETS 300-686 specify the input return-loss requirements for E3, shown in **Table 1**, and the output return-loss requirements, shown in **Table 2**.

Table 1. Input Port Minimum Return Loss

Frequency Range (kHz)	Return Loss (dB)
860 to 1720	12
1720 to 34368	18
34368 to 51550	14

Table 2. Output Port Minimum Return Loss

Frequency Range (kHz)	Return Loss (dB)
860 to 1720	6
1720 to 51550	8

Measuring Return Loss

The test setups and procedures for measuring E3 return loss are described in subclauses A.2.5 and A.2.6 of the ETS 300-686 specification. The test configuration in **Figure 1** is designed to measure the input return loss and verify compliance with the requirements shown in Table 1. The output return-loss configuration uses the same equipment, but connects it to the transmitter output instead of the receiver input.

In the Figure 1 setup, the return-loss bridge is A57TLSTD from Wide Band Engineering Company, Inc. Two 50Ω/75Ω impedance converters (A65L from Wide Band Engineering) interface the 75Ω bridge with the 50Ω generator and 50Ω spectrum analyzer ports. The precision 75Ω resistor to the right of the bridge is built into the return-loss bridge. An Advantest R3132 spectrum analyzer serves as both the signal generator and the spectrum analyzer.

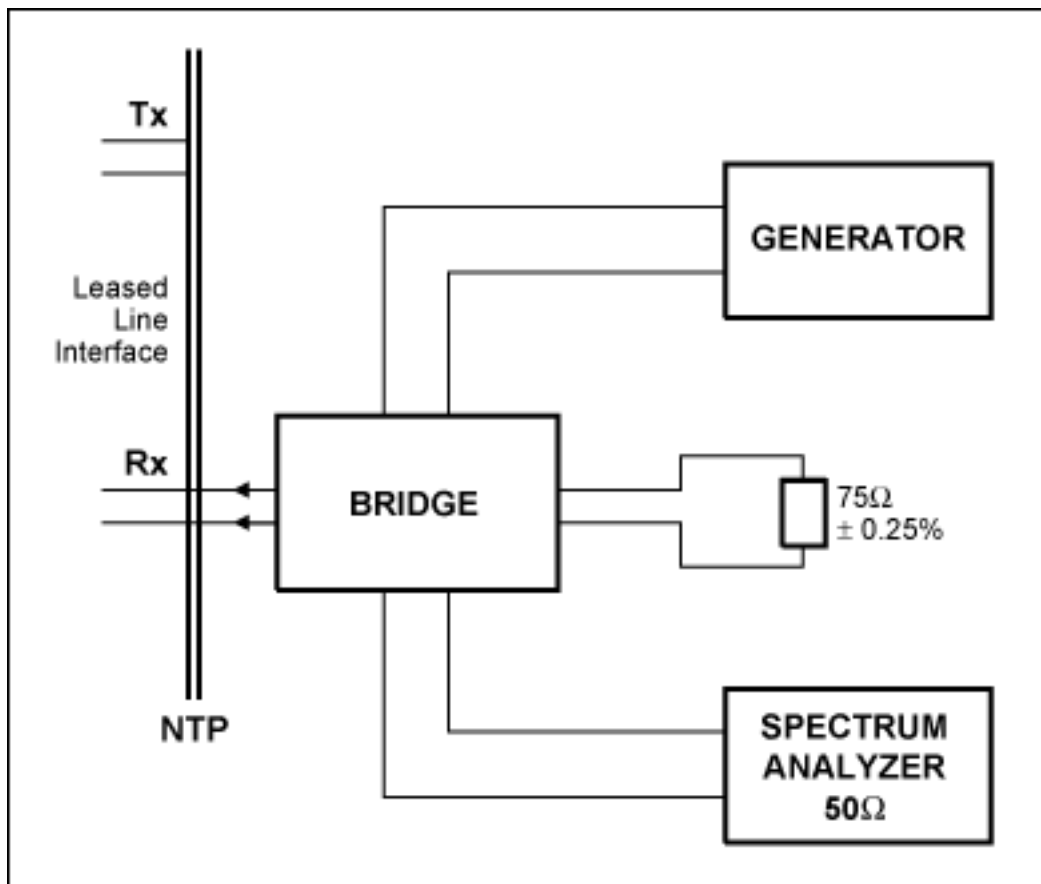

Figure 1. Setup for measuring return loss.

In the Figure 1 setup, the generator is supplying a sinusoidal 1V peak signal at frequencies ranging from 860kHz to 51,550kHz.

To check the test setup before making return-loss measurements, the NTP interface of the bridge at the left in Figure 1 should be connected to a $75\Omega \pm 0.25\Omega$ test load. In the Maxim setup this precision resistor is a component from Wide Band Engineering that comes with the return-loss bridge. With this test load the return loss should be 20dB higher than the requirements shown in Table 1. **Figure 2** shows the return loss measured with the Maxim setup. This setup measured a 45.27dB return loss at 1720kHz.

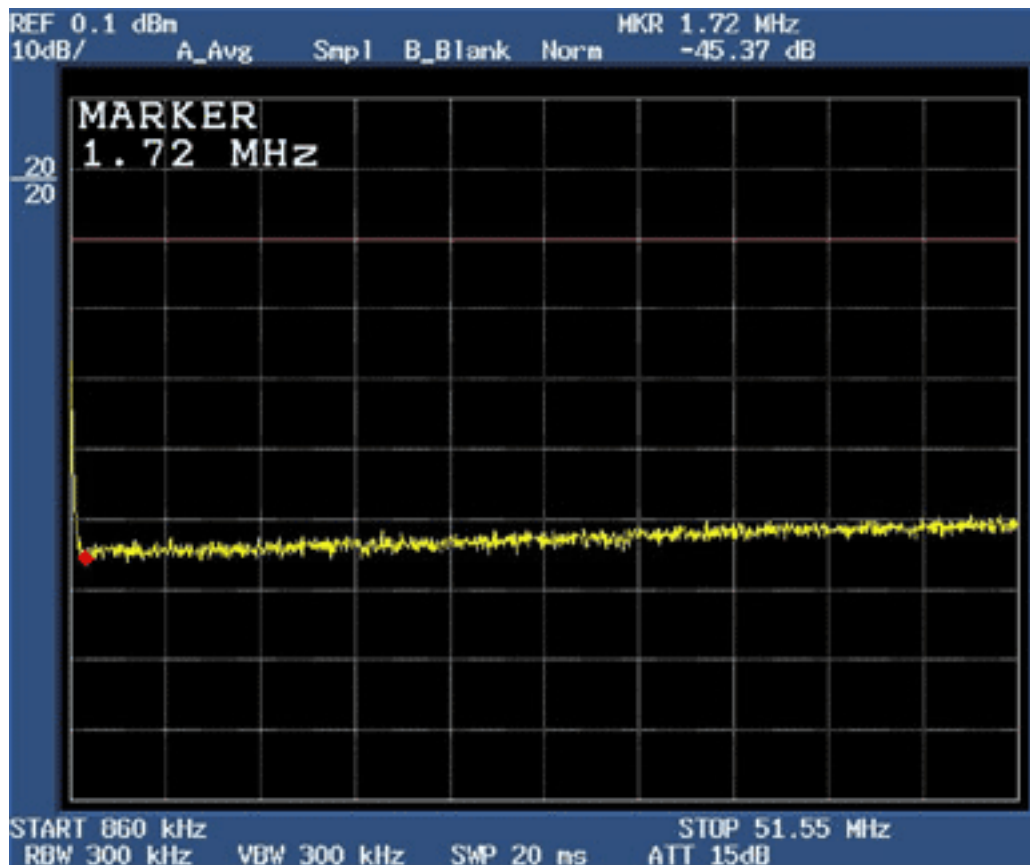

Figure 2. Return loss of 75 Ω test load.

When the NTP interface of the bridge was connected to the receiver of the DS3174DK or DS3184DK design kit using a standard 330 Ω termination resistor, the measured return losses at 34.37MHz were 16.86dB for the DS3174 and 16.43dB for the DS3184, as shown in **Figure 3** and **Figure 4** respectively. These values do not meet the requirements of Table 1.

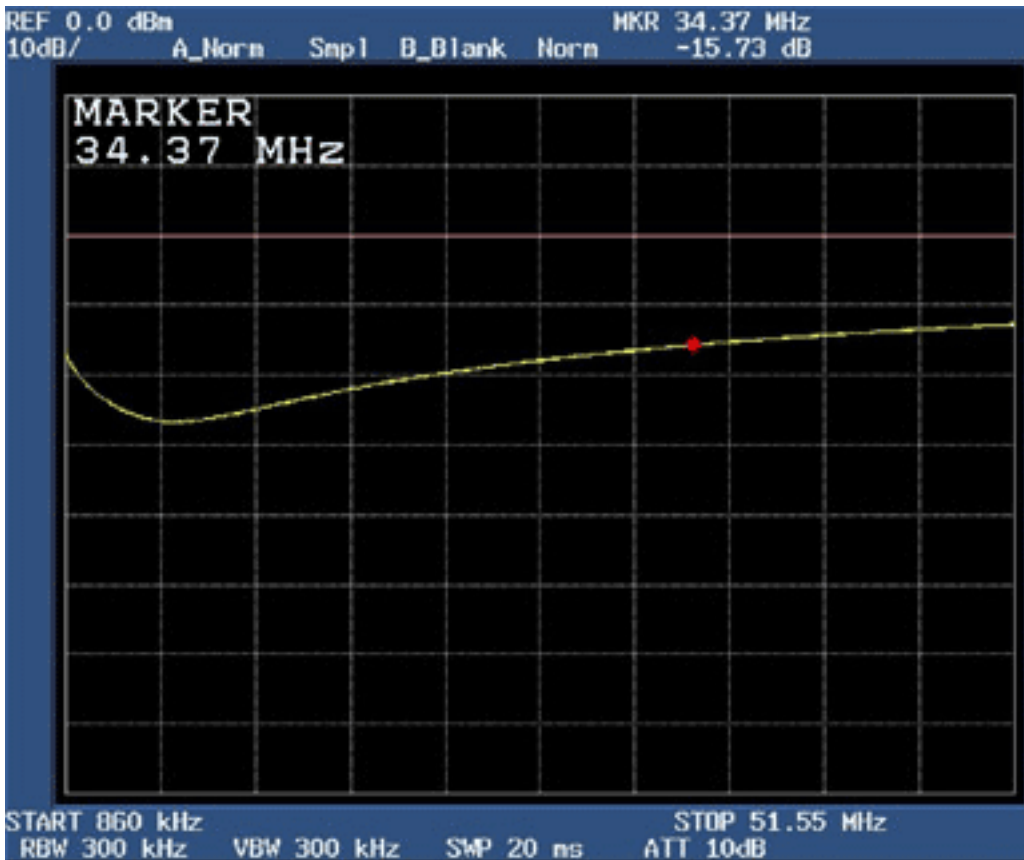

Figure 3. Return loss of the DS317x with termination network at 34.37MHz.

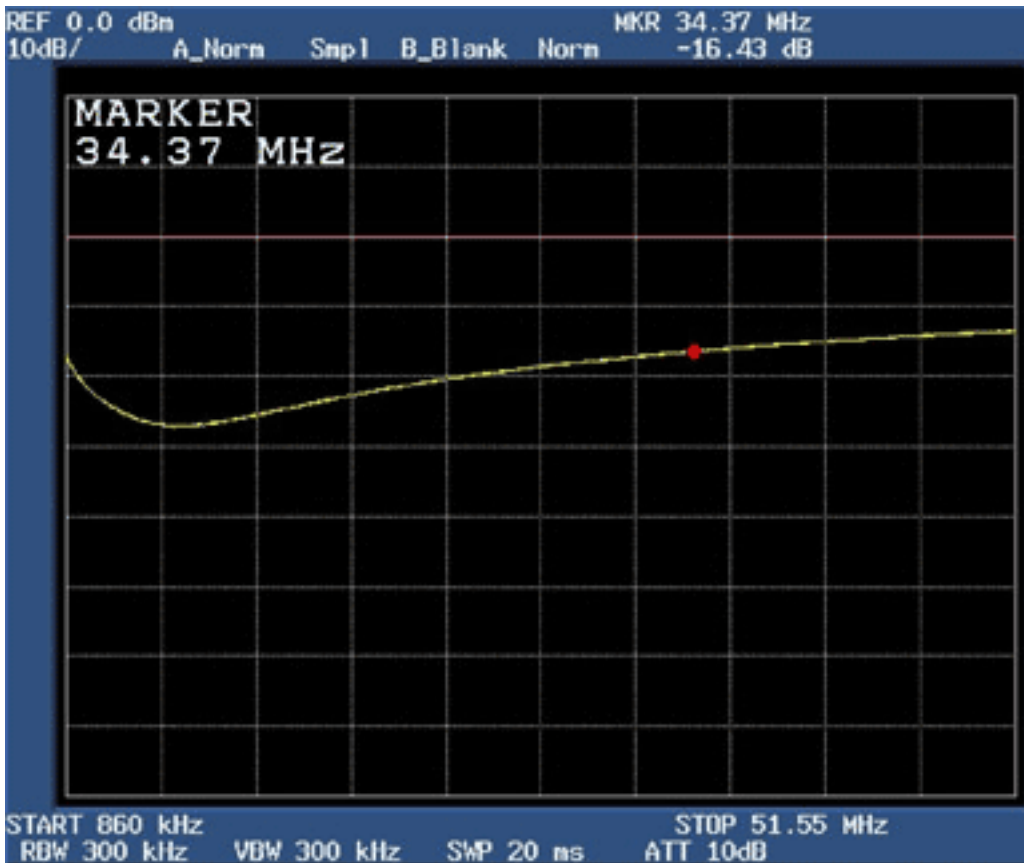

Figure 4. Return loss of the DS318x with termination network at 34.37MHz.

The NTP interface of the bridge was connected to the receiver of the DS3174DK or DS3184DK design kit using a standard 330Ω termination resistor. **Figure 5** and **Figure 6** show the measured return losses at 51.55MHz, 12.80dB for the DS3174 and 13.55dB for the DS3184. These return-loss values also do not meet the

requirements of Table 1.

It is clear, therefore, that return loss must be improved to meet the defined requirements.

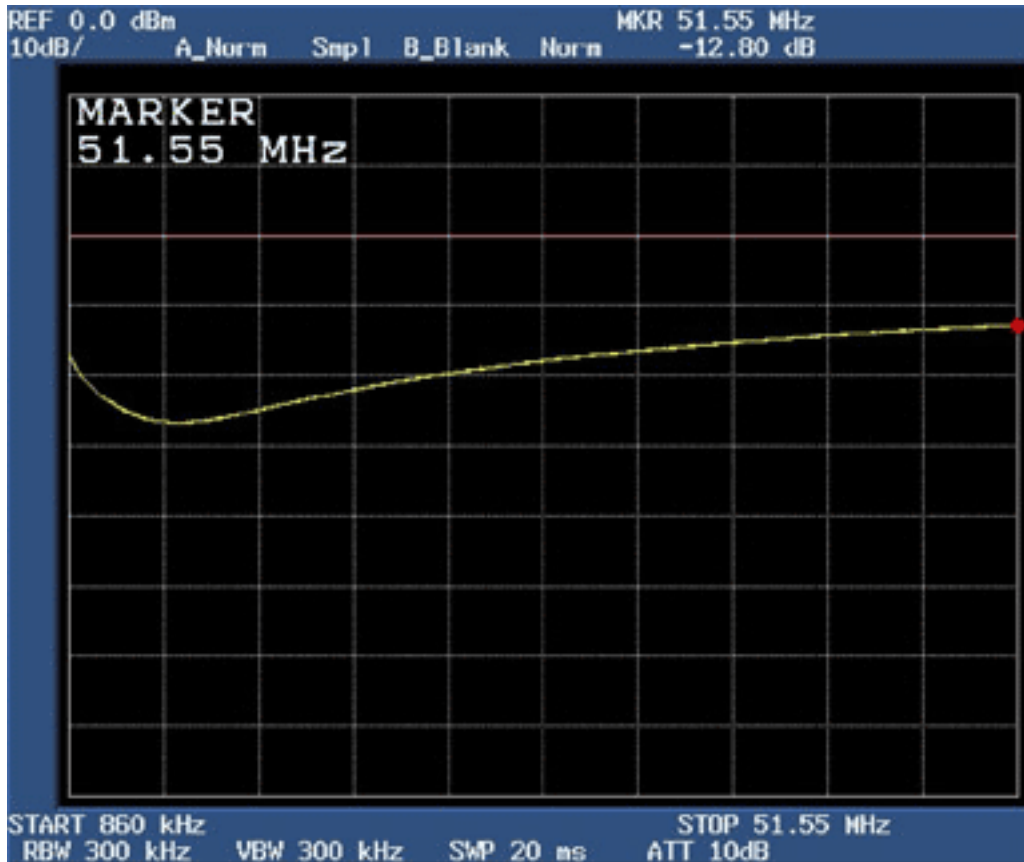

Figure 5. Return loss of DS317x with termination network at 51.55MHz.

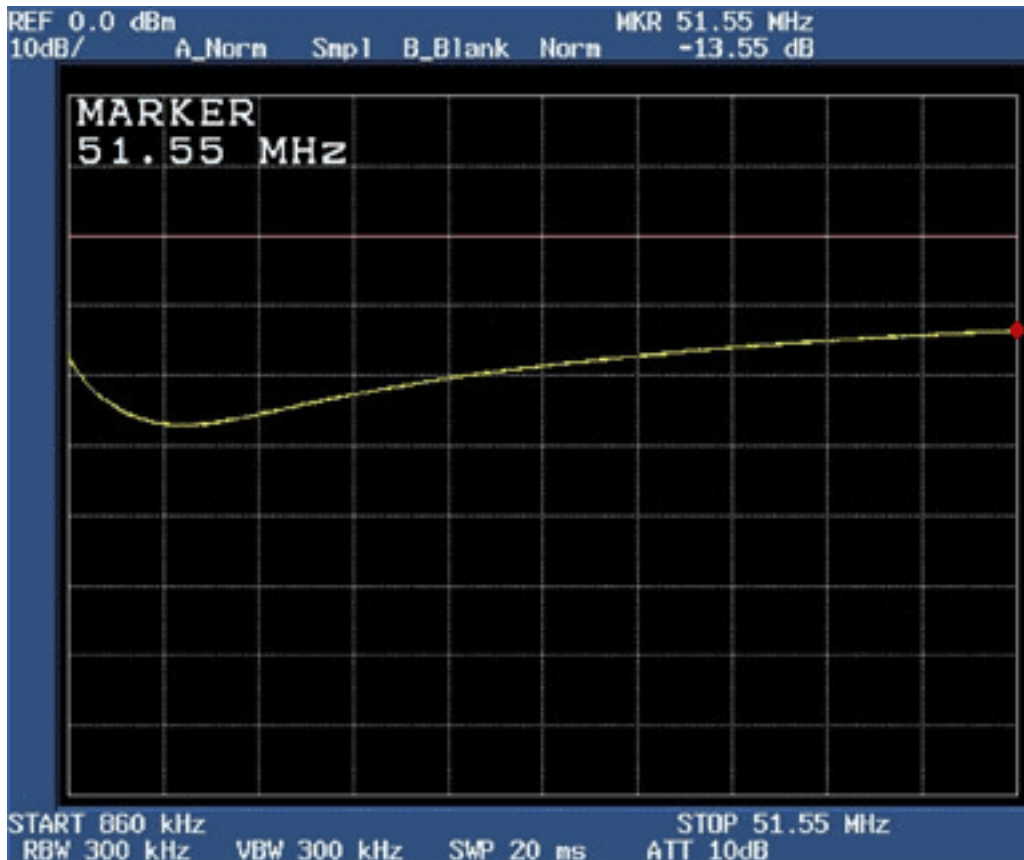

Figure 6. Return loss of DS318x with termination network at 51.55MHz.

Improving Return Loss for the DS317x and DS318x

We can improve return loss on these LIUs by adding a 100nH inductor in series with the primary coil. That change was made on both the DS317xDK and DS318xDK design kit boards. **Figure 7** shows this modified standard termination network for the DS317x and DS318x receiver.

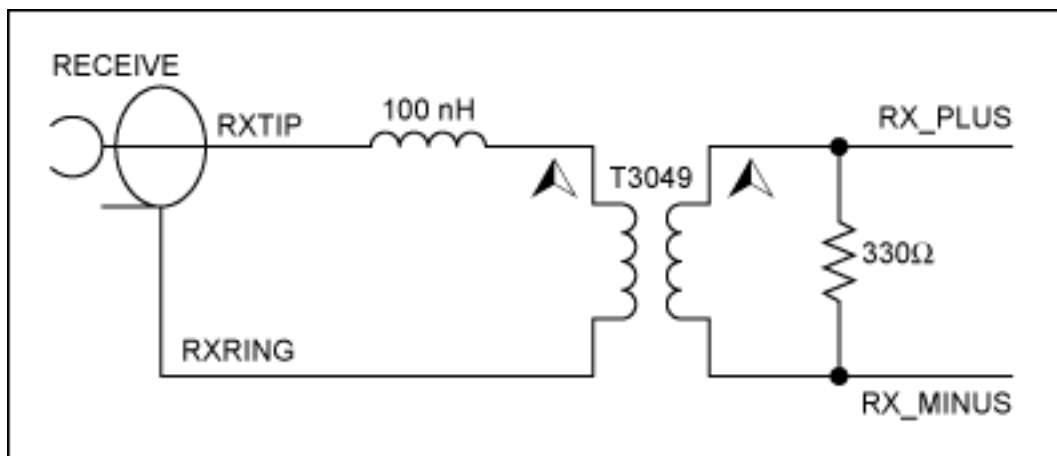

Figure 7. The modified termination network for the DS317x and DS318x LIUs.

Figure 8 shows that the return loss for the DS317x with the 100nH inductor and 330Ω termination resistor is 21.65dB at 34.37MHz. **Figure 9** shows that the return loss for the DS318x, also with the 100nH inductor and 330Ω termination resistor, is 22.16dB at 34.37MHz. Both of these return-loss values meet the requirements in Table 1.

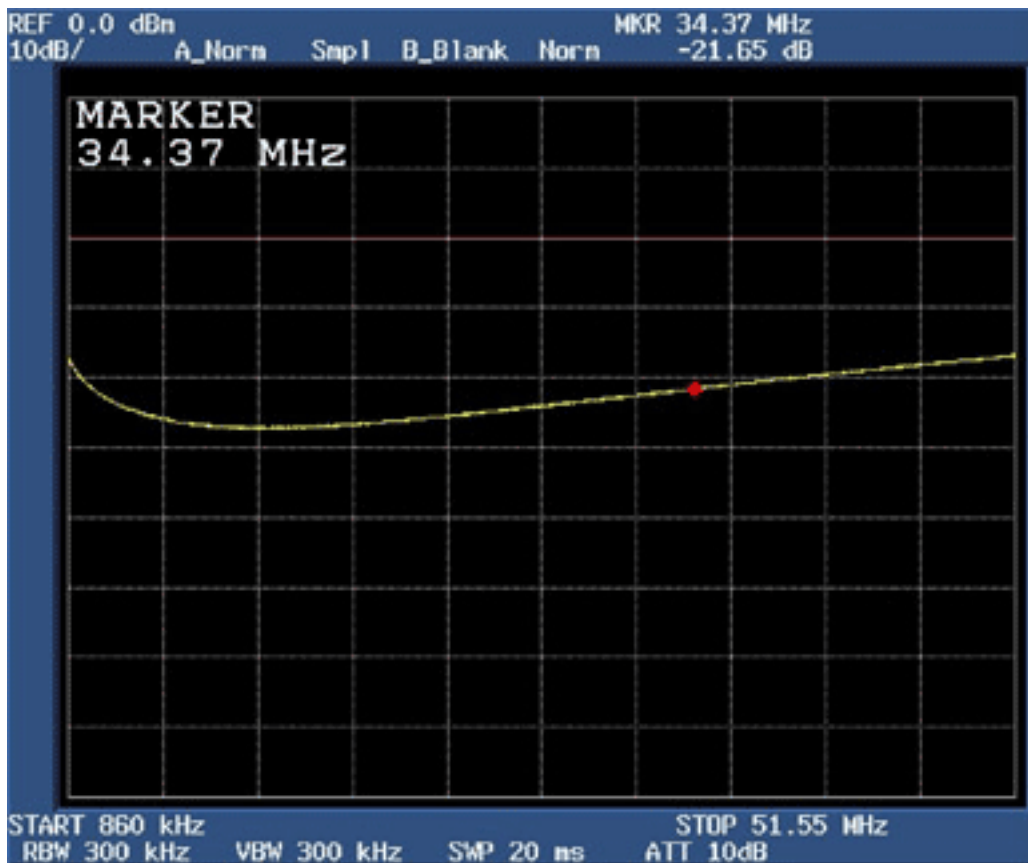

Figure 8. Return loss of the DS317x with modified termination network at 34.37MHz.

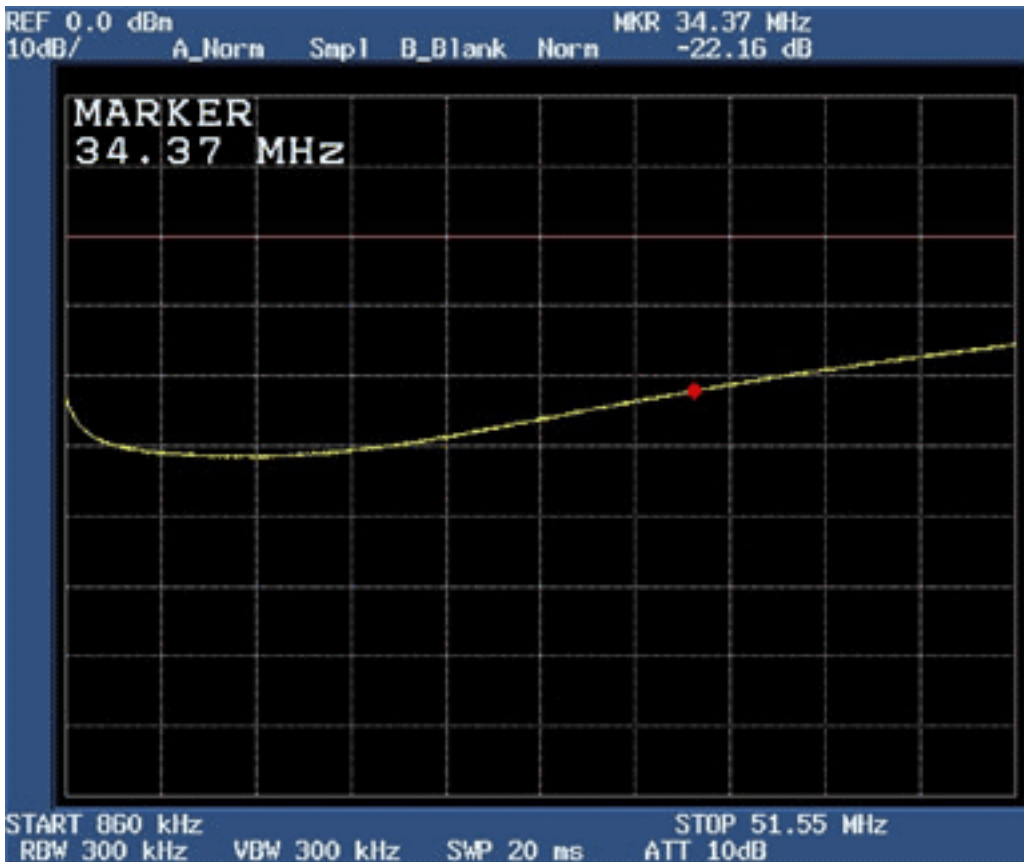

Figure 9. Return loss of the DS318x with modified termination network at 34.37MHz.

Figure 10 shows that the return loss for the DS317x with the 100nH inductor and 330Ω termination resistor is 16.85dB at 51.55MHz. **Figure 11** shows that the return loss for the DS318x, also with the 100nH inductor and 330Ω termination resistor, is 15.49dB at 51.55MHz. Both of these return-loss values meet the requirements in Table 1.

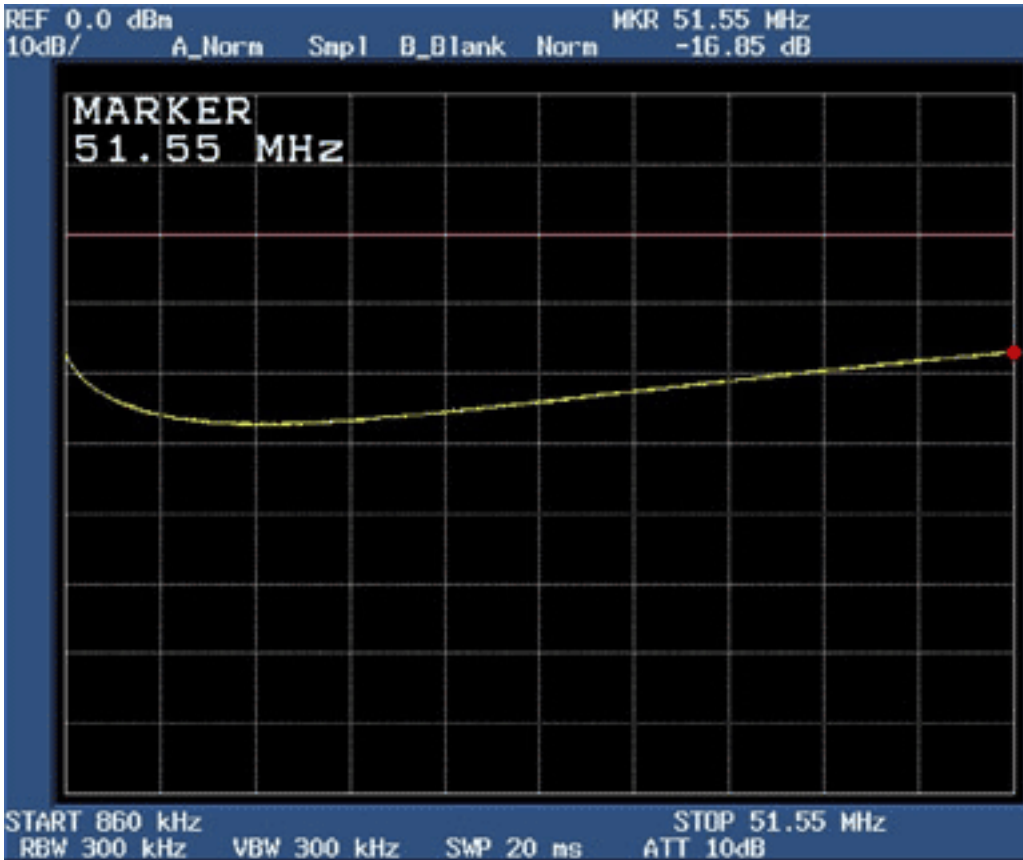

Figure 10. Return loss of the DS317x with modified termination network at 51.55MHz.

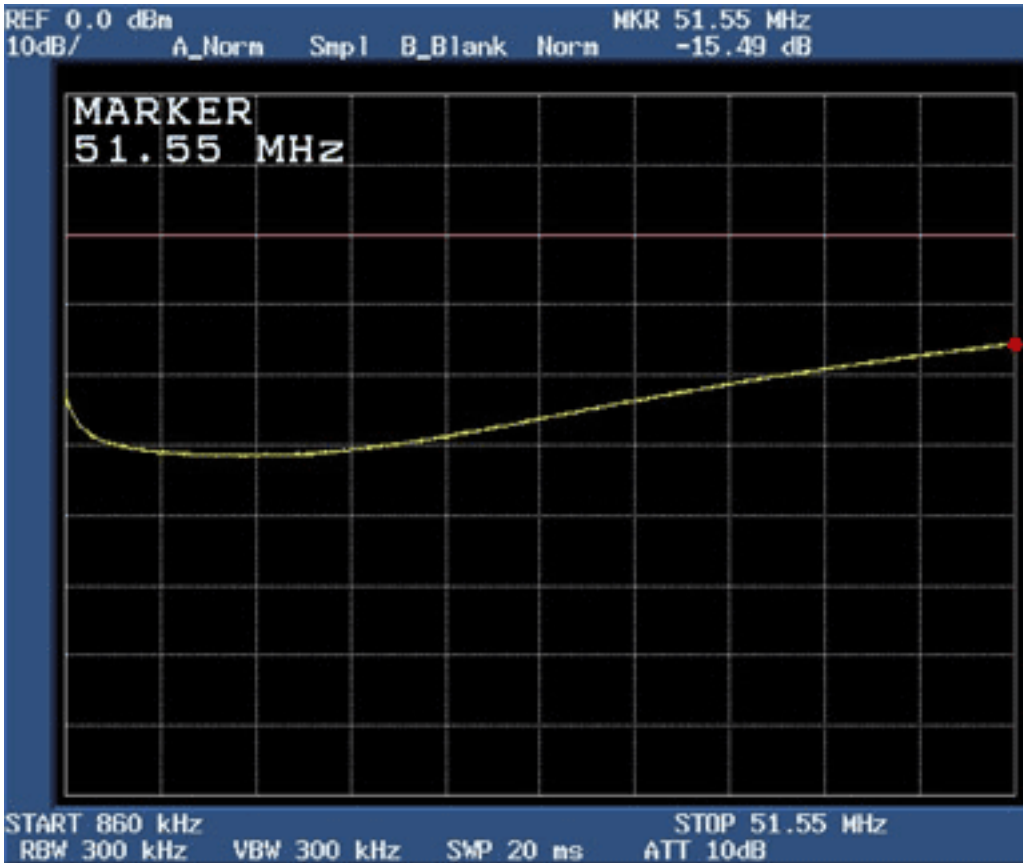

Figure 11. Return loss of the DS318x with modified termination network at 51.55MHz.

Conclusion

The return-loss measurement techniques and termination resistor adjustments described above are also applicable for other Maxim DS3/E3/STS-1 line interface units (LIUs) and transceivers (SCTs). The decision to modify the design to meet the return loss specifications should be made after measuring the board with the ideal 330Ω termination resistor. If the return loss requirements are not met with a 330Ω resistor, the termination resistor value can be adjusted or an inductor can be added in series with the primary coil as needed to meet the return loss requirements.

If you have further questions on return loss or any other aspects of using Maxim telecom products, please contact the Telecom Products applications support team through our [Tech Support Center](#) or by phone at (01) 972-371-6555.

Application note 3763: www.maxim-ic.com/an3763

More Information

For technical support: www.maxim-ic.com/support

For samples: www.maxim-ic.com/samples

Other questions and comments: www.maxim-ic.com/contact

Automatic Updates

Would you like to be automatically notified when new application notes are published in your areas of interest? [Sign up for EE-Mail™](#).

Related Parts

DS3171: [QuickView](#) -- [Full \(PDF\) Data Sheet](#) -- [Free Samples](#)

DS3172: [QuickView](#) -- [Full \(PDF\) Data Sheet](#) -- [Free Samples](#)

DS3173: [QuickView](#) -- [Full \(PDF\) Data Sheet](#) -- [Free Samples](#)

DS3174: [QuickView](#) -- [Full \(PDF\) Data Sheet](#) -- [Free Samples](#)

DS3181: [QuickView](#) -- [Full \(PDF\) Data Sheet](#) -- [Free Samples](#)

DS3182: [QuickView](#) -- [Full \(PDF\) Data Sheet](#) -- [Free Samples](#)

DS3183: [QuickView](#) -- [Full \(PDF\) Data Sheet](#) -- [Free Samples](#)

DS3184: [QuickView](#) -- [Full \(PDF\) Data Sheet](#) -- [Free Samples](#)

AN3763, AN 3763, APP3763, Appnote3763, Appnote 3763

Copyright © by Maxim Integrated Products

Additional legal notices: www.maxim-ic.com/legal