



APPLICATION NOTE 3687

Quantitative Analysis Yields Objective Measurement for Audio Amplifier Click and Pop

Abstract: Click and pop refers to the unwanted, audio-band transient signals reproduced by a headphone or speaker when the amplifier driving the transducer is either enabled or disabled. Until recently, the industry's characterization of this undesirable effect has typically been subjective. Phrases such as "low pop noise" and "clickless/popless operation" illustrate the subjectivity used to quantify click-and-pop performance. To remove subjectivity from the assessment of audio amplifier performance, Maxim has determined an objective figure of merit to describe the click-and-pop phenomenon. This figure of merit, K_{CP} , and the test procedure required to obtain this parameter are described in this article.

Introduction

Product differentiation in portable audio devices is a hot topic. What makes product A better and more desirable than its specified rival, product B? From a performance viewpoint, the usual audio figures of merit, such as frequency response flatness and THD+N, can be too similar between competing products to reveal the better performer. The user interface is an obvious differentiator, but this too involves subjective assessment. Nonetheless, there is an objective audio performance parameter that can set one product above another.

An important audio performance differentiator is the occurrence of 'clicks' and 'pops' (henceforth cited as 'click and pop') or other strange, transient noises heard through the headphones (or speakers) when the unit is turned on or off. As time and familiarity raise performance expectations, transient-free audio performance is becoming an important differentiator, a crucial selling point for portable audio devices. Until recently, the industry's characterization of the undesirable click-and-pop effect has usually been subjective. Phrases such as "low pop noise" and "clickless/popless operation" illustrate the subjectivity applied to quantifying click and pop. Customer expectations are changing, however. Designers now need, and want an objective figure of merit to describe the click-and-pop phenomenon.

This article presents a method that both quantifies this click-and-pop parameter and allows meaningful, repeatable comparisons to be drawn among different components.

Click and Pop Characterized

Click and pop refers to the unwanted, audio-band transient signals reproduced by a headphone or speaker when the amplifier driving the transducer is either enabled or disabled. In portable audio applications, where power saving is key to extending battery life, functional blocks are often disabled when not required. That functional design requirement magnifies the potential for click and pop. An ideal component would exhibit no audible output when the device is enabled or disabled. In practice, however, all audio amplifiers exhibit click and pop to some degree. Depending on the sensitivity of the transducer (speaker or headphone) used, its distance from your ear, how well the amplifier handles this transition, and how sensitive is your hearing, the click-and-pop effect can be inaudible. While determining an audible threshold involves many factors, one can characterize the amplifier output (independent of any acoustic transfer function) for quantifiable product comparisons.

The events likely to cause transient signals in an amplifier can be broadly grouped into the operations shown in **Table 1**.

Table 1. Transient Noise Events in Amplifiers

1. Powered up (power applied)	Category A
2. Powered down (power removed)	
3. Brought out of shutdown (power applied previously)	Category B
4. Forced into shutdown (power still applied)	

Maxim separates audio tests into two categories to rationalize the K_{CP} measurements. Referring to **Table 1** above, item 1 (power up) and item 2 (power down) are designated Category A. One usually assumes that for normal operation, any Maxim part with a shutdown (SHDN) function has mode transitions controlled by that pin (or register bit) when power is applied. Category A is not representative of normal usage, so is relevant only when measuring parts which cannot be shutdown under software control. Items 3 and 4 (Category B measurements) more closely represent normal use.

Figures 1 and 2 demonstrate (in the time domain) the transient events associated with bringing two different headphone amplifiers out of shutdown. Compare the transient amplitude of the first, AC-coupled headphone amplifier to the second, DC-coupled headphone amplifier. The AC-coupled headphone amplifier (Figure 1) produces a large transient when coming out of shutdown. This transient will produce a predominantly low-frequency sound, resulting from its relatively slow turn-on sequence. (Note that the time scale is 100ms/div.)

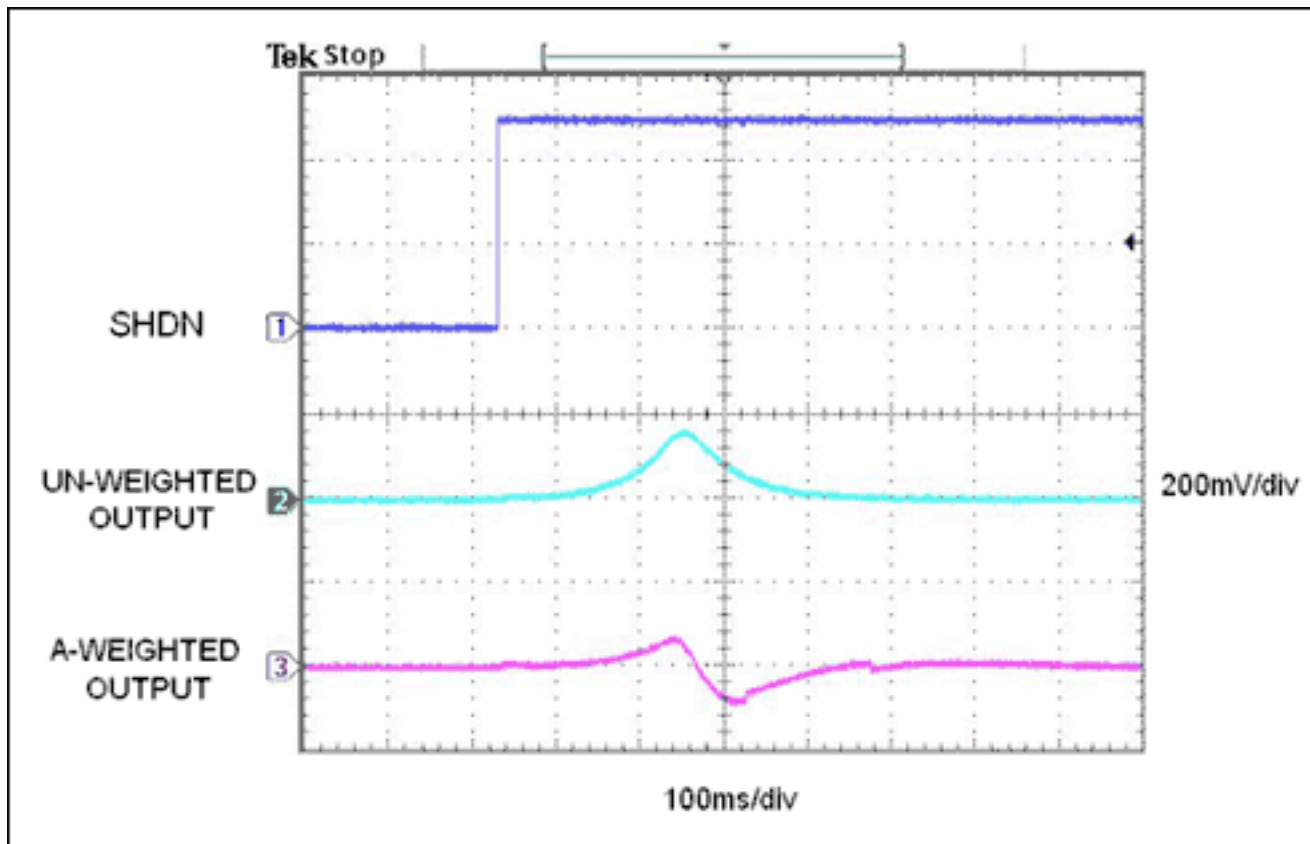

Figure 1. Data show the transient events associated with a particularly well-behaved, AC-coupled headphone amplifier brought out of shutdown. Although high in amplitude, this transient will produce a predominantly low-frequency sound, to which the ear is less sensitive.

The transient of the second, DC-coupled headphone amplifier (Figure 2) appears to be lost in the noise floor of the oscilloscope prior to A-weighted filtering. For this type of amplifier, most of the audible event derives from the shift in DC-voltage offset from shutdown to full operation. As the offset is a few millivolts, an unfiltered scope trace will not accurately determine the magnitude of the click or pop. Applying A-weighted filtering, the click and pop caused by the offset of the DC-coupled headphone amplifier is extracted from the noise floor and a more objective measurement is recorded. (Note that the V/div scale of the post-filtered signal is not recorded to scale.)

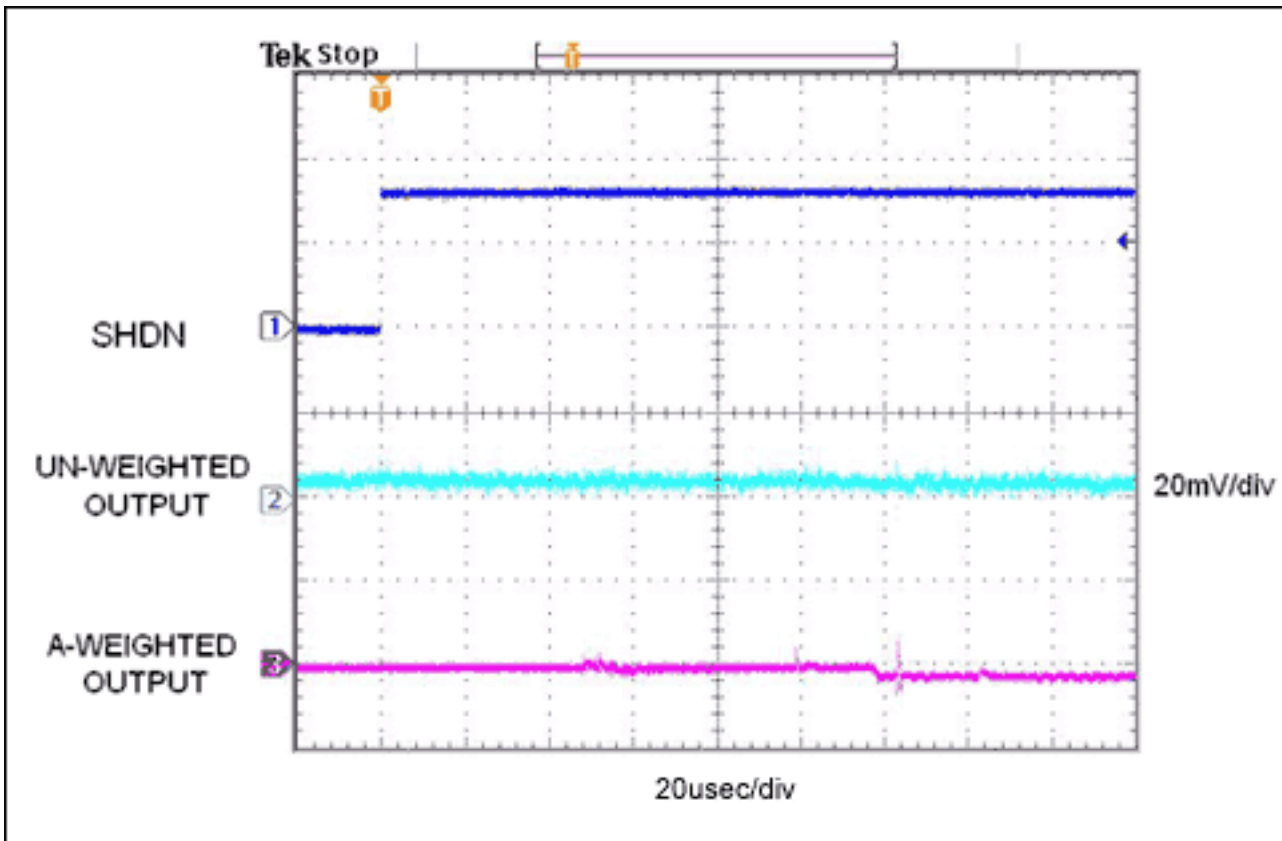

Figure 2. Data show the transient events associated with a low-offset, DC-coupled headphone amplifier brought out of shutdown. The amplitude is much lower in comparison to Figure 1 (hence subjectively quieter), and the amplifier is fully enabled after 150 μ s.

There are two main areas to address in analyzing this problem. First, how can the transient be measured objectively? Second, what, if any, pass/fail criteria can be applied to the measured results?

Click-and-Pop Measurement Method

Maxim's method for measuring click-and-pop performance (**Figure 3**) employs a System One or System Two (preferred) audio analyzer from Audio Precision. The test method can also be implemented with equivalent test equipment from other manufacturers¹. The proposed figure of merit, K_{CP} , is an objective measure of audio-amplifier click-and-pop performance.

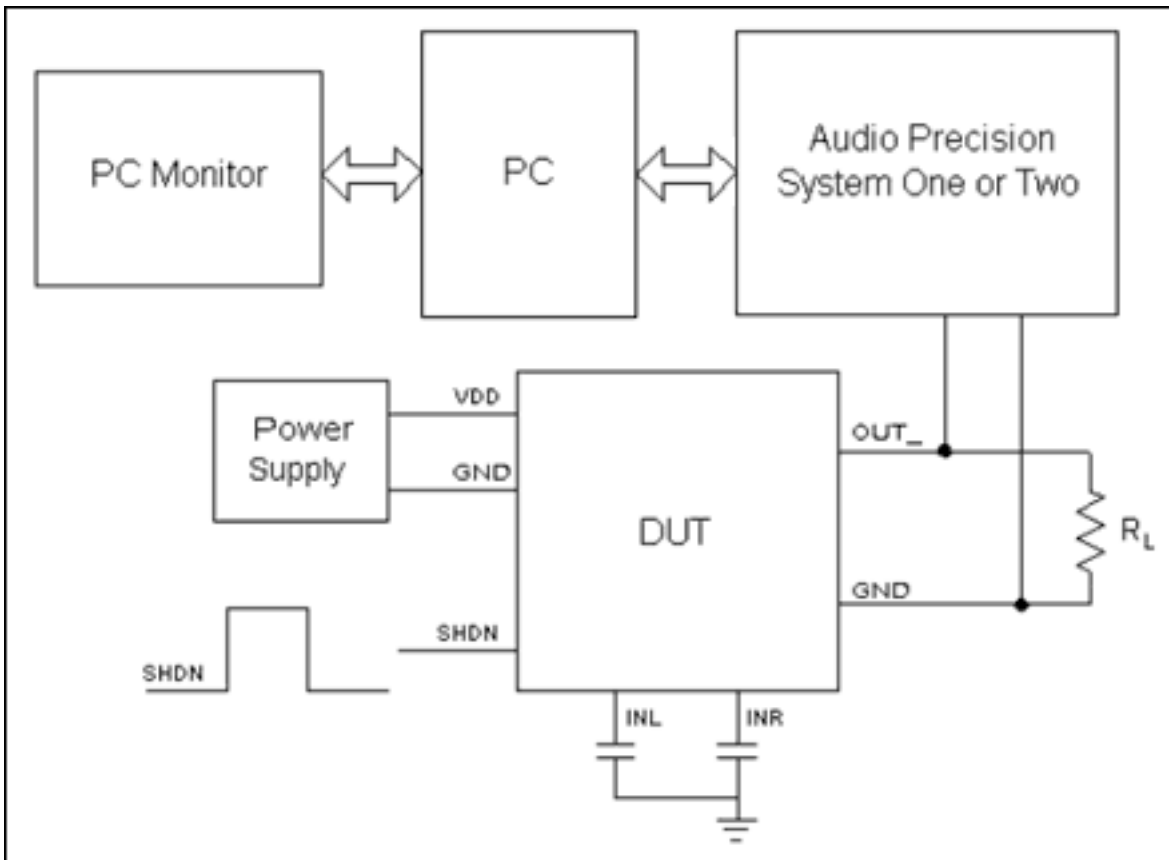

Figure 3. Test setup for click-and-pop measurements in headphone amplifiers. Note that the left and right input pins are AC-coupled to ground. The outputs are loaded with typical headphone impedance and the shutdown pin is toggled by a square wave generator.

To begin the method, connect the output of the device under test (DUT) to the expected load impedance or a simulated (dummy) version of that impedance. Make the required SHDN and power signals available to the DUT, and AC-ground all DUT inputs. No input signal is necessary; the input stimulus consists of moving the DUT between its various modes of operation and non-operation. Connect the DUT output to the analog-analyzer section of the audio analyzer.

Next, select the analyzer's A-weighted filtering option (preferred) or the unweighted 22Hz to 22kHz filters, and limit the measurement bandwidth to the audio frequency range. Remember that an oscilloscope display of a fast, high-level transient is not an indication of how much energy will appear in the audio band. The human ear has a limited frequency response, as does the loudspeaker or headphone that tries to follow the transient. Thus, the addition of A-weighted filtering (**Figure 4**) is arguably more useful in the analysis, because it emphasizes those frequencies to which the ear is more sensitive. Some audio analyzers lack the ability to apply A-weighting, in which case it is important to limit the bandwidth frequencies to whichever the human ear responds. A popular bandwidth limitation in audio test equipment is 22Hz to 22kHz, presumably to allow bandwidth-limiting filters to have a flat response up to 20kHz (usually quoted as the upper limit for the human ear).

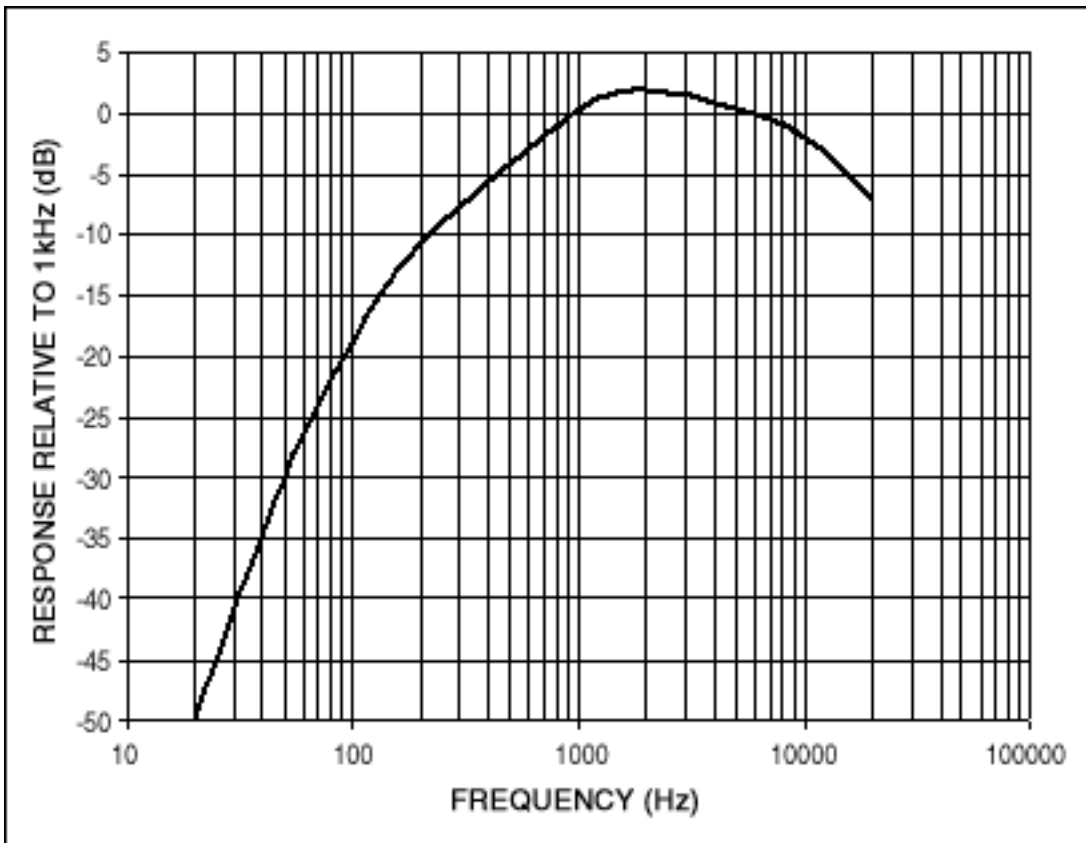

Figure 4. Frequency response of the A-weighted filter. This parameter is often used for noise measurements, as the frequency balance approximates the ear's sensitivity. Note that the filter transfer function is unity gain (0dB) at 1kHz, and attenuates the frequency extremes.

Set the detector to peak reading (rather than the usual RMS setting), and set the detector sampling to 32 samples per second. RMS detection is meaningless for a transient event like what we are trying to capture. System Two analyzers allow higher sampling rates, but the 32 samples-per-second rate allows the option of obtaining equivalent measurements from a System One audio analyzer. (The 32 samples-per-second is the fastest acquisition setting on the System One model.) Disable the auto-ranging circuitry of the audio analyzer and manually select a range that will accurately track the expected peak-signal amplitude. System One and System Two analyzer ranges are in 4X(12.04dB) steps from 1X to 1024X (0 to 60.21dB). A 1X/Y range for audio amplifier click-and-pop measurements is a suggested starting point for highest accuracy measurements.

Drive the SHDN pin with a low-frequency square wave to allow acquisition of repeated measurements. The frequency at which SHDN is cycled should be below the audio bandwidth, and the period should be long enough to ensure that all turn on/off audio events are captured (some parts exhibit long turn-on delays). At Maxim, the rate chosen is usually 0.5Hz.

The analyzer's bar-graph option lets you easily monitor the DUT's transient behavior when making a transition between operation and shutdown. Peak voltages are easily determined, and the bar graph can be quickly reset between measurements. Peak voltages are recorded in dBV (dB relative to 1V). This figure of merit is referred to as K_{CP} .

The Importance of the Test Equipment

The above test allows comparison between similar parts and yields a repeatable, objective result. One is advised to ensure that the test equipment reacts in a linear manner to any magnitude of input. For example, the peak reading when tested with a 1mV impulse response should be 40dB lower than that of a 100mV impulse of the same pulse width. (See the **Appendix** on calibration of test equipment).

An oscilloscope with some external filtering could, of course, be used for this objective click and pop measurement. Nonetheless, experience shows that the typical level of click-and-pop for quality headphone amps is in the millivolt range, which can be challenging to estimate accurately on most scopes. Testing higher voltage

devices, such as high-power amplifiers, is possible using an oscilloscope.

Repetitive Testing for an Average Value

Part-to-part variation will likely yield slightly different results. Therefore, before judging a poor-performing part harshly, test more than one device to measure the variation. In a competently designed, DC-coupled headphone amp, most of the click and pop will be proportional to input-offset voltage, which unless trimmed (or otherwise removed) will vary between different parts. To ensure consistent results when fully characterizing a part, test the transition to and from each mode of operation multiple times. Then calculate an average value. If the part is to go into production, then testing more than one part is advisable. Test all channels of a stereo or multichannel device.

Establishing an Absolute Voltage Level

An absolute voltage level for click and pop should be specified according to the amplifier's application. Suppose, for example, that a device is characterized to produce a -50dBV transient when going into shutdown. If the DUT is a 50W/8Ω power amplifier, full scale will be +29dBV peak. Consequently, the ratio of the perceived click to the maximum peak voltage that this amplifier can deliver is:

$$-(+29 - (-50)) = -79\text{dB}$$

compared to the peak signal. If, however, the DUT is a 20mW/16Ω headphone amplifier, full scale will be around -1.9dBV peak, producing a less impressive ratio of -48.1dB relative to peak volts.

Setting Performance Levels

Although we already described a method for deriving an objective figure of merit for click-and-pop behavior, a question still remains: How good is good enough?

Consider the following. After testing two headphone amplifiers using the method outlined above, you have repeatable K_{CP} results for Category B click-and-pop suppression with -59dBV for the first amplifier and -61dBV for the second. Is the second device really a lot quieter than the first device? Or, are both sets of results acceptable? The measurement is objective, but the interpretation of 'acceptability' remains subjective.

An acceptable, or even detectable, level of click-and-pop suppression depends on several variables: the expected headphone/speaker efficiency, the typical distance of the transducer from the listener, the rate at which SHDN is cycled, and the assumed level of background noise when listening.

Despite the many variables that affect where one establishes an acceptable click-and-pop performance level in any given application, we can specify a credible performance benchmark. Note the results for Category B click-and-pop tests on Maxim's headphone amplifiers (**Table 2**). A 32Ω resistive load was used for all test runs, and each K_{CP} value represents the average of four different samples for each part.

Table 2. K_{CP} Values for Headphone Amplifiers (A-Weighted, 32/sec, Peak Voltages, 32Ω Load)

Part Number	K_{CP}		Comments
	Into SHDN (dBV)	Out of SHDN (dBV)	
MAX9750C Headphone Amp	-55.8	-47.9	+3dB gain setting
MAX9760 Headphone Amp	-57.4	-56.2	Unity gain, 15kΩ resistors, 220μF output capacitors
MAX4410	-69.9	-77.8	Unity gain, 10kΩ resistors
MAX4299	-59.1	-49.4	Category A (no SHDN)

The above data are Maxim's benchmark for K_{CP} performance. To reduce and eventually eliminate the subjective factor in amplifier performance assessment, Maxim encourages other semiconductor suppliers to adopt this methodology and the defined K_{CP} parameter. For more information on topics covered in this test, please visit the links below.

1. Maxim's [audio product](#) information
2. Maxim's [Audio Discussion Group](#)
3. [Audio Precision Worldwide Network](#) for standards in audio test and measurement.

A similar article appeared in the March, 2005 edition of *EDN*.

¹ Equivalent manufacturers include Rhode & Schwartz (Audio Analyzer) and Prism Sound (dScope).

Appendix. Calibrating Equivalent Equipment

The method for deriving an objective figure of merit for click-and-pop performance presented in this application note uses a System One or System Two audio analyzer from Audio Precision. What can one do if a System One or System Two audio analyzer is unavailable?

The K_{CP} performance measurement can be acquired by using equivalent test equipment from other manufacturers. **Figure A** shows a generic test setup for an audio analyzer and DUT.

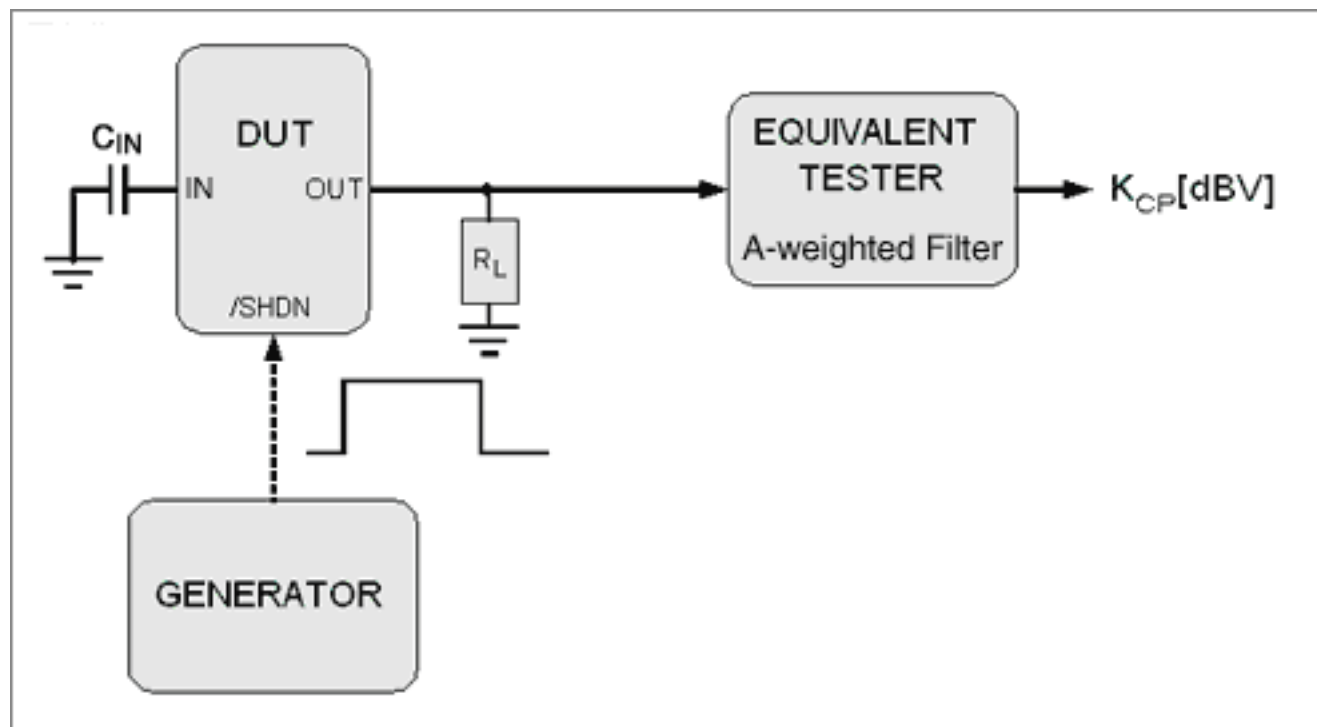

Figure A. A test setup for click-and-pop measurements using equivalent test equipment from other manufacturers.

This test setup should be calibrated before accurate measurements are recorded and direct comparison of results are made. In addition, one needs to verify that the amount of energy recorded by the equivalent analyzer is, in fact, linear with the varying input amplitude. Only then can one be sure that the click-and-pop energy is accurately represented, especially when reacting to fast rising transients with significant energy above the audio band. Simple calibration requires a function generator and an equivalent analyzer. (Refer to Figure B for illustration.) Calibration is performed in the following manner:

1. Apply a known-amplitude, 0.5Hz square-wave signal directly to the input of an equivalent audio analyzer.

2. Set the equivalent audio analyzer to detect A-weighted, peak voltages.
3. Record the peak voltage reading of various input signal amplitudes.

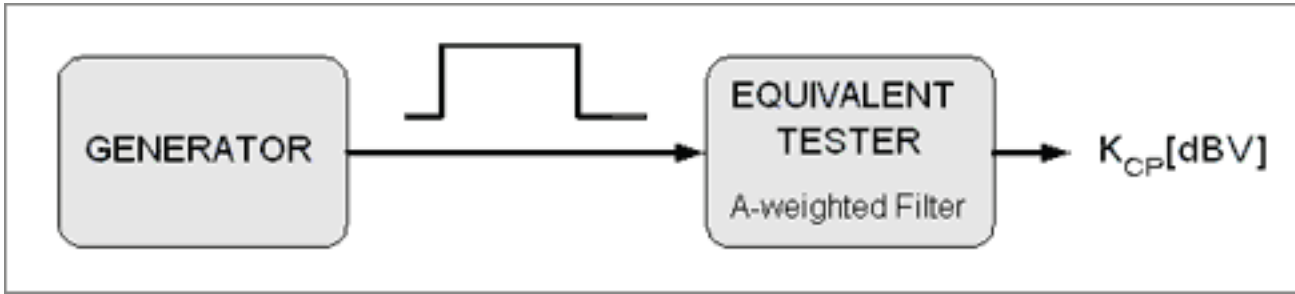

Figure B. Test setup for calibration of equivalent audio analyzers. Calibration must be performed to ensure that the amount of energy recorded by the equivalent analyzer is linear with the varying input amplitude.

Table A below shows the calibration results of a System Two Audio Precision audio analyzer set to detect A-weighted, peak voltages at 32 samples/second. An auto-range setting of 1X/Y yields a consistent 6dB weighted factor for input signals ranging from 1mV_{P-P} to 40mV_{P-P}. This 6dB weighted factor is associated with the limited, A-weighted transfer function of the Audio Precision analyzer. At input signals > 40mV_{P-P}, the calibration results become nonlinear for this particular setup. This range is adequate for most amplifiers.

Table A. Audio Precision System Two Calibration Results

V _{IN} (mV _{P-P})	V _{THEORETICAL} (dBV)	V _{READING} (dBV)	A-Weighted Calibration
1	-60.000	-66.295	6.295
5	-46.021	-52.391	6.370
10	-40.000	-46.186	6.186
20	-33.979	-39.883	5.904
40	-27.958	-34.120	6.162
60	-24.437	-32.140	7.703
80	-21.938	-30.791	8.853
100	-20.000	-28.747	8.747

This calibration exercise can be applied to equivalent analyzers to ensure accurate click-and-pop performance measurements. Additionally, once calibration values are identified and an appropriate input signal range is determined, one can accurately compare the click-and-pop performance of two amplifiers characterized with equivalent audio analyzers.

Application Note 3687: www.maxim-ic.com/an3687

More Information

For technical support: www.maxim-ic.com/support

For samples: www.maxim-ic.com/samples

Other questions and comments: www.maxim-ic.com/contact

Automatic Updates

Would you like to be automatically notified when new application notes are published in your areas of interest?

[Sign up for EE-Mail™.](#)

Related Parts

MAX4299: [QuickView](#) -- [Full \(PDF\) Data Sheet](#)

MAX4410: [QuickView](#) -- [Full \(PDF\) Data Sheet](#) -- [Free Samples](#)

MAX9750: [QuickView](#) -- [Full \(PDF\) Data Sheet](#) -- [Free Samples](#)

MAX9760: [QuickView](#) -- [Full \(PDF\) Data Sheet](#) -- [Free Samples](#)

AN3687, AN 3687, APP3687, Appnote3687, Appnote 3687

Copyright © by Maxim Integrated Products

Additional legal notices: www.maxim-ic.com/legal