



APPLICATION NOTE 3660

PCB Layout Techniques to Achieve RF Immunity for Audio Amplifiers

Abstract: PCB layout techniques are discussed as a method to optimize the RF immunity performance of an audio amplifier IC. Maxim's MAX9750 IC is highlighted as a case study.

Introduction

RF immunity, or RF susceptibility, is quickly becoming as important a design consideration as PSRR, THD+N, and SNR in the audio world of cellular phones, MP3 players, and notebook computers. Bluetooth is proliferating as a wireless-serial-cable replacement for headsets and microphones in mobile applications. Wireless LAN (WLAN), using the IEEE 802.11b/g protocol, is practically standard in PC and laptop computers. The TDMA multiplexing scheme found in GSM, PCS, and DECT technologies remains a considerable RF nuisance. Today's dense RF environment raises concerns regarding an electronic circuit's susceptibility to RF and RF's impact on the integrity of the overall system. The audio amplifier is a system block susceptible to RF.

An audio amplifier can demodulate the RF carrier and reproduce the modulated signal and its harmonic components at its output. Some of the frequencies fall into the audio baseband, producing unwanted audible 'buzz' at the system's speaker output. To avoid this problem, a system designer must fully understand the limitations of the selected amplifier IC and its respective PCB layout. This article will guide designers to optimize the RF immunity performance of an audio amplifier at the board level.

Finding the Source of RF Noise

The key to a successful layout (i.e., high immunity to RF) is first to identify the source of RF noise coupling. If an evaluation kit is available for the selected audio amplifier, use it to identify the pins susceptible to RF. Pick a frequency of interest in the system, 2.4GHz, for example, in a WLAN application. Antenna theory states that a trace length of ~1.2in (a quarter wavelength of the 2.4GHz RF signal) is a highly efficient antenna at 2.4GHz.

$$l = c/(4*f)$$

where l = length, c = 3×10^8 , f = frequency.

Cut a 1.2in wire and solder it directly to a pin on the IC. Measure (see **Appendix** below) the IC's RF-immunity performance at the frequency of interest (2.4GHz \pm 10%). Remove the 1.2in wire and solder it to a different pin on the amplifier. Repeat the RF measurement. It is important to ensure that the test setup is identical for each test run. Continue in this fashion until the 1.2in wire has been placed at every amplifier pin and an RF measurement recorded at the frequency of interest. Finally, measure the IC's RF immunity performance without an antenna connected at the pins.

The last test run provides a baseline for the amplifier's performance. Compare this result to the previous series of test runs. The comparison will identify the amplifier pins most susceptible to RF demodulation. Given this data, a PCB can be optimized to reduce the amount of RF noise coupled into the amplifier pins.

MAX9750 Case Study: Engineering evaluation has identified nine pins on the MAX9750 IC that demonstrate susceptibility to RF: INL, INR, BIAS, VOL, BEEP, OUTL_, and OTR_.

The Role of the Capacitor

Take, for example, the BIAS pin of the selected IC. Assume that the BIAS pin exhibits poor RF immunity at the frequency of interest. The first, and most obvious PCB consideration would be to limit the trace length from the BIAS

pin to the decoupling capacitor. If the trace length is optimized and RF demodulation is still a concern, consider adding a small bypass cap (on the order of 10pF to 100pF) to GND at the amplifier pin. The capacitor's impedance profile can create a notch filter at the system's most sensitive frequency (in this case, 2.4GHz). Refer to the impedance profile of a capacitor model (C1) in **Figure 1A** below.

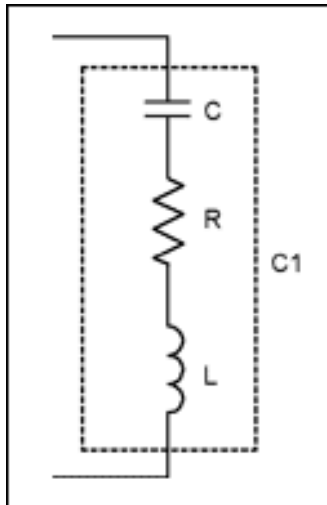

Figure 1A. Nonideal capacitor model.

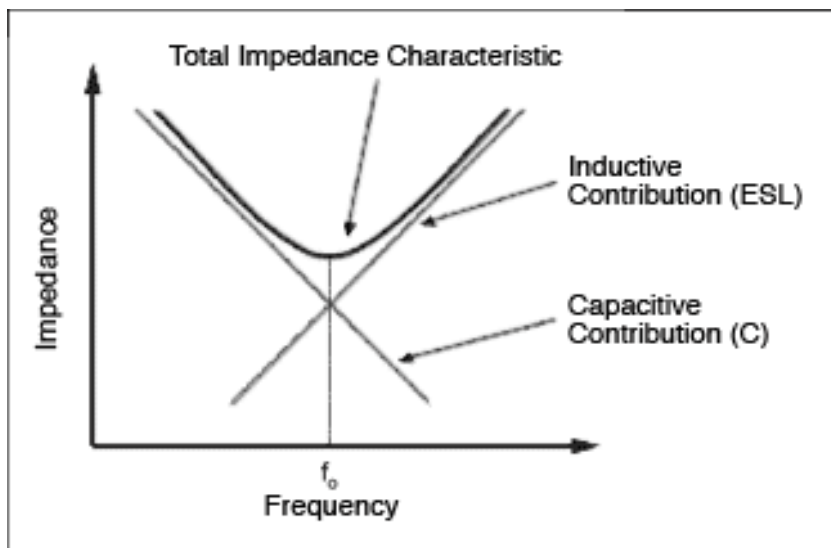

Figure 1B. Nonideal capacitor model, impedance profile.

If C1 were an ideal capacitor, the impedance profile would decrease as the frequency increased ($X_C = 1/[2\pi \times f \times C]$).

Ideal capacitors do not, however, exist in a practical environment. The impedance of a nonideal capacitor model (**Figure 1B**) takes a dip at self-resonance* and then begins to increase with frequency. The inductive component takes over ($X_L = 2\pi \times f \times L$) at frequencies greater than f_0 . This behavior may produce disappointing results if the capacitor is selected for a filter operating at frequencies near or above its self-resonance. However, if the capacitor is selected to shunt high-frequency components to GND, the capacitor's self-resonance soon becomes more useful.

MAX9750 Case Study: A 33pF capacitor added at the BIAS pin improved RF immunity performance on average by 3.6dB.

Controlling Noise at the Input Pins

An audio amplifier's input pins will always be a source of RF noise coupling. Ensure that the input trace lengths are shorter than 1/4 the wavelength of the system's RF signal. A quiet ground plane can also be implemented to reduce the amount of RF noise coupled into the input pins. Flood the system's quiet ground plane around each input trace of the IC. This ground plane will aid in isolating any high-RF signals from the input pins of the selected audio amplifier.

MAX9750 Case Study: A 3x reduction of input trace length and a ground plane flood around the left, right, and PC-beep input pins further improved the RF immunity performance of the MAX9750 IC (**Figure 2**).

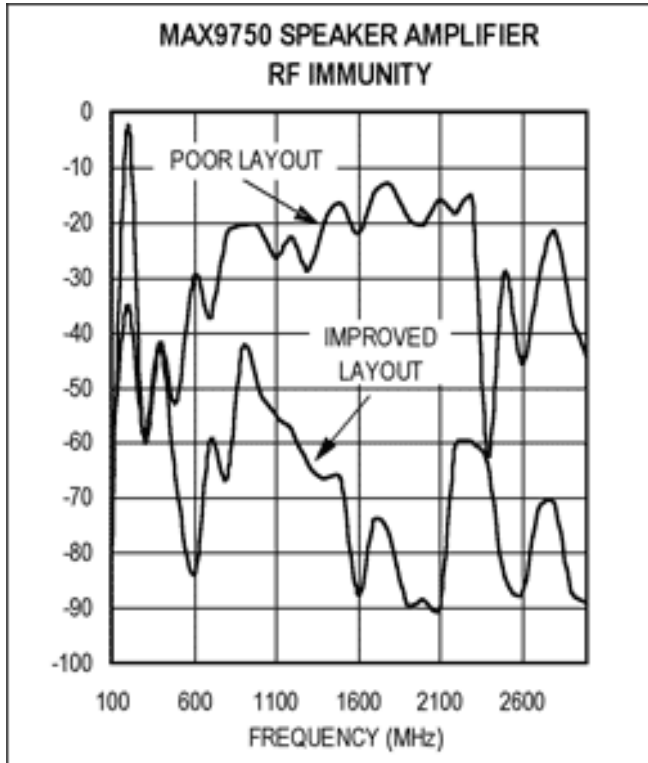

Figure 2. RF immunity test results of the MAX9750C speaker amplifier, Noise Floor = -94.4dBV.

Note: Figure 2 demonstrates the typical RF immunity performance of the MAX9750 IC. External factors such as antenna strength, cable length, speaker type, etc., can also affect the RF immunity performance.

Expensive methods such as LC filters on RF-susceptible amplifier pins or low-ESR capacitors added to the application diagram can also be implemented at board level. These methods are very effective, but costly. If the source of RF noise is identified and understood, expensive solutions can be avoided.

Summary

Poor RF immunity performance of an audio amplifier will impact the integrity of the overall system design. If the problem is identified and understood, corrective action can be taken to ensure that audible RF demodulation is avoided. In general, keep the input, output, bias, and power supply traces shorter than 1/4 the wavelength of the system's RF signal. If a higher level of RF immunity is required, connect a small-value capacitor to ground directly at the pin of the IC (even when a larger value capacitor is already connected at the pin). Utilize ground plane floods near highly susceptible amplifier pins. Finally, physically place high-RF energy system blocks away from highly susceptible audio amplifier pins. Equipped with this general understanding, the unwanted audible demodulation 'buzz' can be eliminated.

* At self-resonance, the capacitive and inductive impedances cancel each other out leaving only a resistive component. The selfresonance is given by

$$f_0 = \frac{1}{2\pi\sqrt{LC}}$$

Appendix

To obtain accurate and repeatable test results, the device under test (DUT) must be exposed to a known RF field strength. Maxim developed a test method for quantifying repeatable RF-susceptibility results by use of an RF anechoic test chamber, a signal generator, RF amplifiers, and a field-strength sensor.

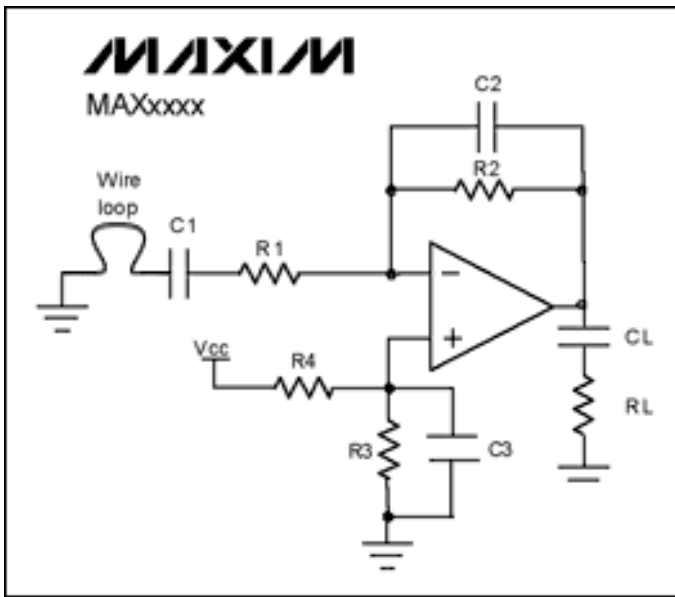

Figure A. An RF immunity test circuit.

Figure A above represents a typical test setup for an operational amplifier (op-amp). The amplifier's non-inverting input is shorted to GND, using a 1.5in wire loop to simulate a PCB trace length. A standard 1.5in input trace length is selected so that RF immunity performance can be compared across several Maxim amplifiers (note that an input trace from the DUT to the input source may effectively act as an antenna at the system's sensitive frequency band). The amplifier's output is loaded with an expected load. Next, the amplifier is placed in an anechoic test chamber. The demodulated signal is monitored at the amplifier's output as Maxim's RF Anechoic Test System simulates an RF-rich environment.

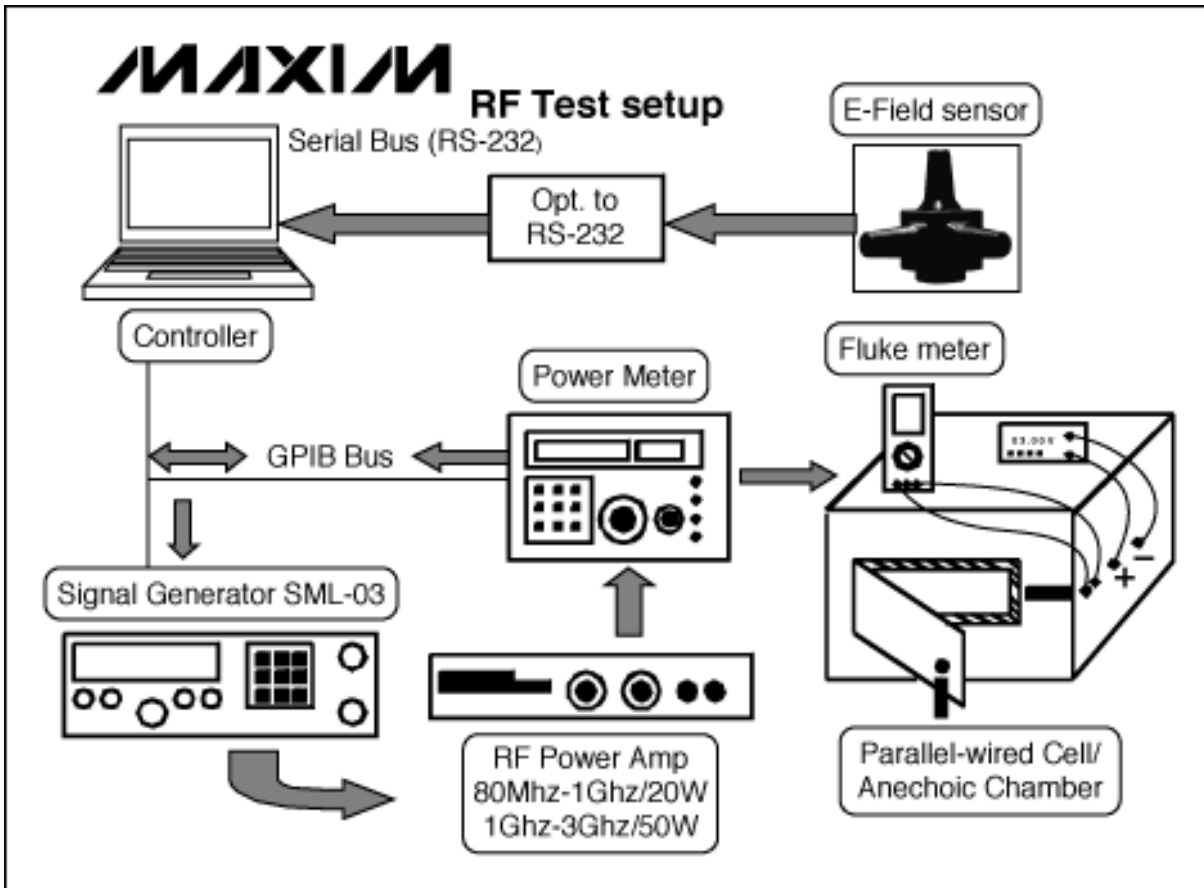

Figure B. Maxim's RF immunity test method.

Figure B illustrates Maxim's RF Anechoic Test System, which simulates the RF field environment necessary for RF immunity testing. The test chamber is similar to a Faraday's Cage, isolating the DUT from external electrical fields.

The complete test set-up is comprised of the following equipment:

- Signal generator: SML-03, 9 KHz to 3.3GHz (Rhode & Schwarz)
- RF power amplifier: 20MHz to 1000MHz, 20W (OPHIR 5124)
- RF power amplifier: 1GHz to 3GHz, 50W (OPHIR 5173)
- Power meter: 25MHz to 1GHz (Rhode & Schwarz)
- Parallel wired cell (Anechoic chamber)
- Electric field-strength sensor
- Computer (PC)
- Fluke DMM (dBV meter)

The PC sets the range of frequencies, modulation percentage, modulation type supplied by the signal generator, and the power delivered by the RF power amplifier. The modulated signal is fed to the appropriate power amplifier (OPHIR 5124 for 20MHz to 1000MHz, 20W or OPHIR 5173 for 1GHz to 3GHz, 50W). The amplifier output is monitored with a directional coupler and a power meter. The defined RF field is uniformly radiated inside the test chamber.

At Maxim, the DUT is placed in the center of the shielded anechoic chamber. A field-strength sensor consistently measures a uniform field strength of 50V/m at the DUT. An RF sine wave whose frequency is varied between 100MHz and 3GHz is 100% amplitude modulated with an audio frequency of 1kHz. Access ports on the side of the chamber provide power to the DUT and a means to connect output monitors. A Fluke multimeter (configured to report units in dBV) monitors the demodulated, 1kHz signal amplitude in real-time. As the RF sine-wave frequency is varied between 100MHz and 3GHz in predetermined steps, the Fluke multimeter reports are recorded. A sample 100MHz to 3GHz sweep is reported below in **Figure C**.

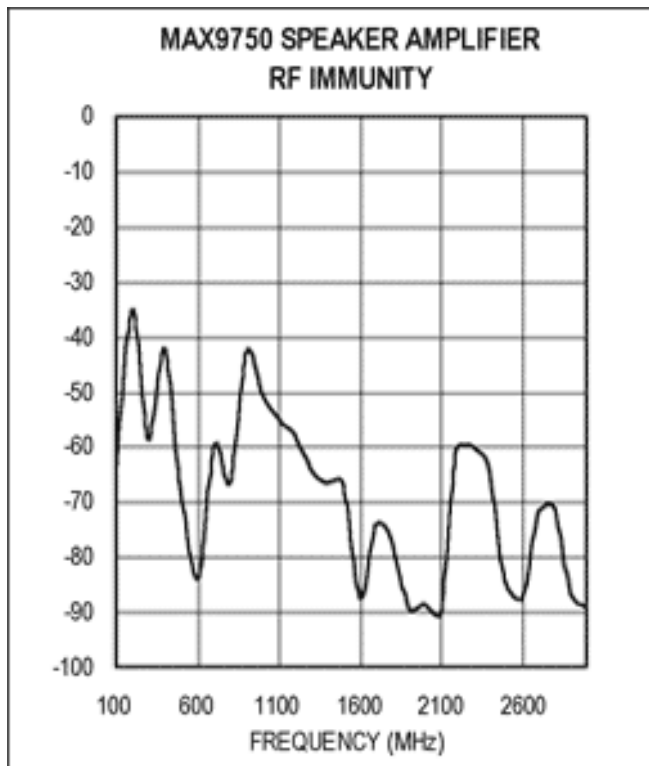

Figure C. MAX9750 RF immunity test results.

Application Note 3660: www.maxim-ic.com/an3660

More Information

For technical support: www.maxim-ic.com/support

For samples: www.maxim-ic.com/samples

Other questions and comments: www.maxim-ic.com/contact

Automatic Updates

Would you like to be automatically notified when new application notes are published in your areas of interest? [Sign up for EE-Mail™](#).

Related Parts

MAX9750: [QuickView](#) -- [Full \(PDF\) Data Sheet](#) -- [Free Samples](#)

AN3660, AN 3660, APP3660, Appnote3660, Appnote 3660

Copyright © by Maxim Integrated Products

Additional legal notices: www.maxim-ic.com/legal