

APPLICATION NOTE 3659

Simple Circuit Converts +5V to -10V

Abstract: This simple charge-pump voltage inverter produces more than -10V at no load, and more than 200mA while the output voltage remains greater than the input.

The versatile switched-capacitor charge pump is easy to use and requires no inductor. It can double a positive voltage or convert a positive voltage to negative.

For some applications in which only a positive supply is available, the system must generate a negative voltage of larger magnitude than the positive rail. For that purpose, the circuit of **Figure 1** inverts the input voltage and doubles the resulting negative output at the same time. The voltage inverter shown (IC1) converts a positive input to a negative output voltage, normally with an absolute magnitude lower than that of the input. But in this circuit, the two Schottky diodes and the two capacitors at the output produce a higher output voltage.

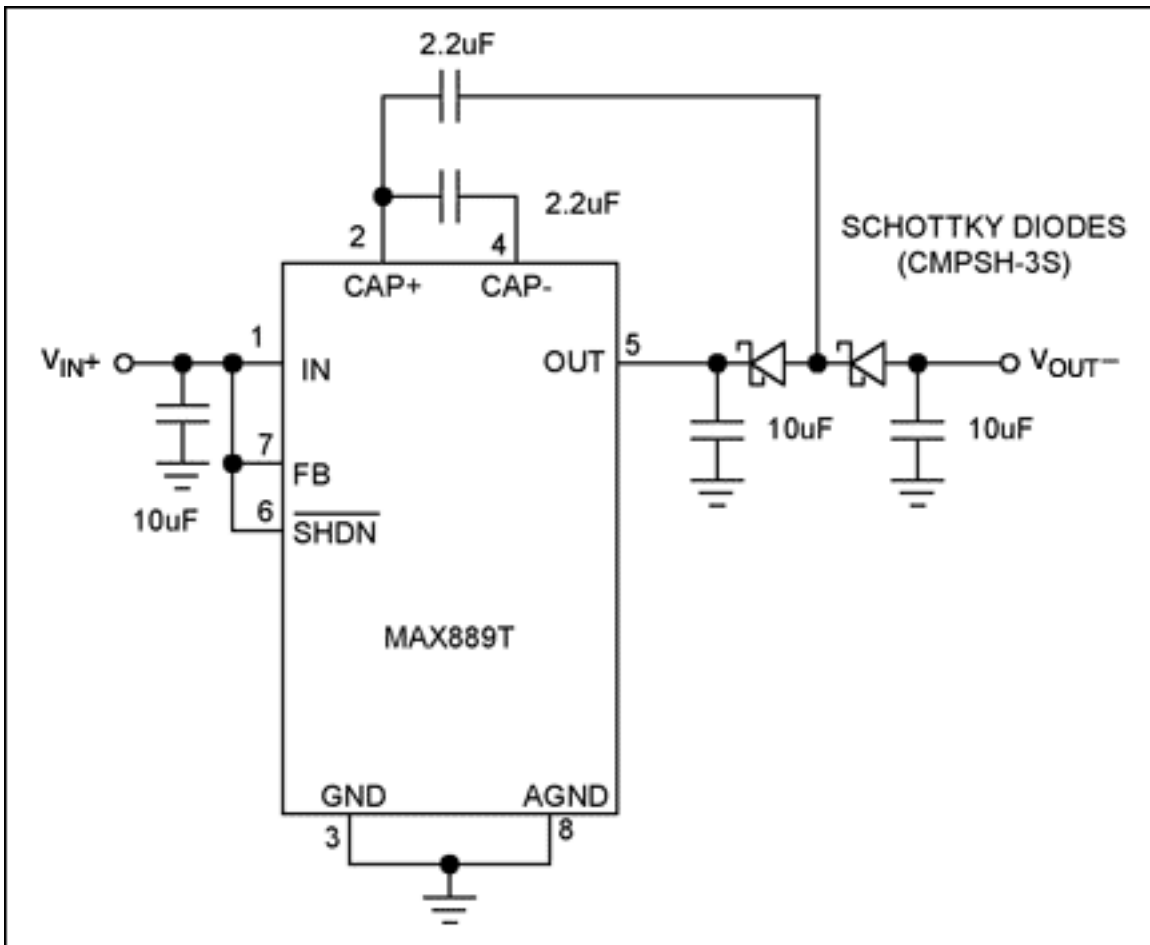

Figure 1. This simple circuit derives -10V from +5V.

The expected output is $V_{OUT} = -(2 \times V_{IN} - 2V_D - I_{OUT} \times R_O)$, where V_D is the voltage drop across a diode, I_{OUT} is the output current, and R_O is the output resistance. While the maximum expected voltage is -10V, overshoot across the capacitors due to parasitic inductance in the capacitors and traces produces more than -11V at no load (**Figure 2**).

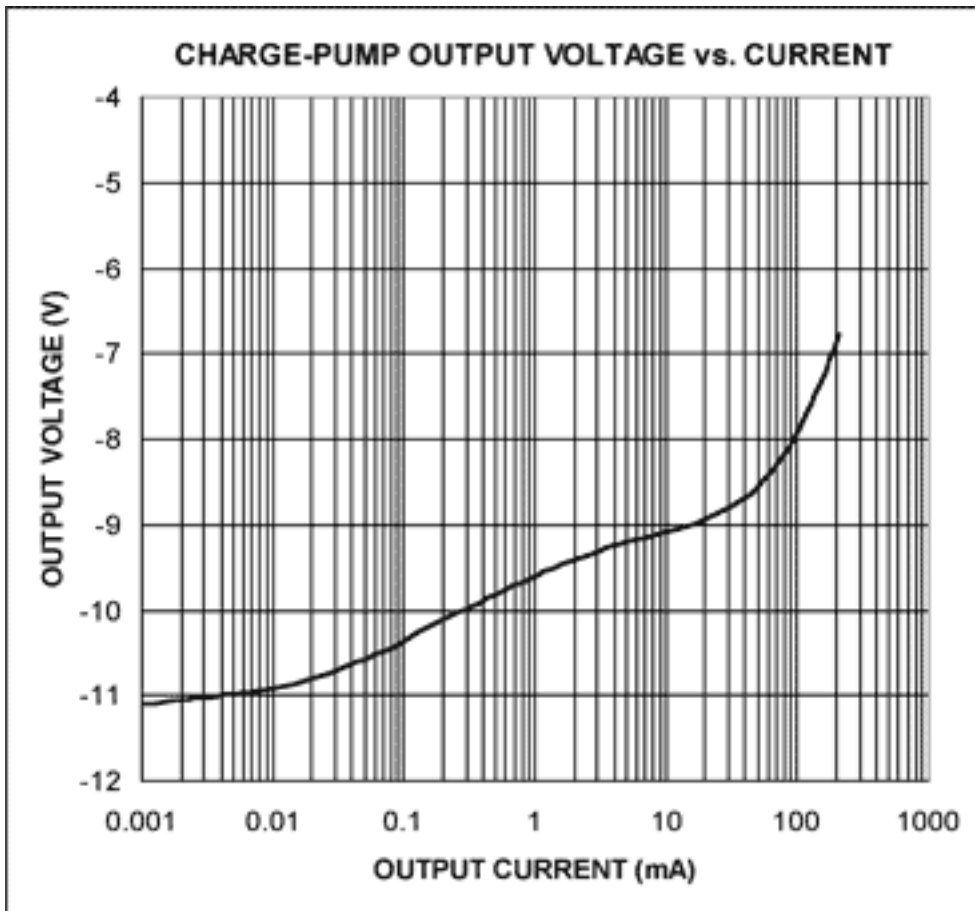

Figure 2. The circuit in Figure 1 above produces more than -10V at no load, and more than 200mA while the output voltage remains greater than the input.

This design idea appeared in the May 26, 2005 issue of *EDN* magazine.

Application Note 3659: www.maxim-ic.com/an3659

More Information

For technical support: www.maxim-ic.com/support

For samples: www.maxim-ic.com/samples

Other questions and comments: www.maxim-ic.com/contact

Automatic Updates

Would you like to be automatically notified when new application notes are published in your areas of interest?

[Sign up for EE-Mail™.](#)

Related Parts

MAX889: [QuickView](#) -- [Full \(PDF\) Data Sheet](#) -- [Free Samples](#)

AN3659, AN 3659, APP3659, Appnote3659, Appnote 3659

Copyright © by Maxim Integrated Products

Additional legal notices: www.maxim-ic.com/legal