

APPLICATION NOTE 3655

Buffered Linear-Ramp Generator Operates Rail-to-Rail from a Single Supply

Abstract: A precision ramp generator produces a 0 to 5V ramp while operating from a single 5V supply.

Using standard circuits and no auxiliary voltage generators, such as charge pumps or inductive DC-DC converters, it is difficult to build a precision, rail-to-rail ramp generator that operates on a single supply and resets to a well-defined level. **Figure 1** implements such a circuit using a bootstrapped series reference and an op amp with rail-to-rail I/O and very low bias current.

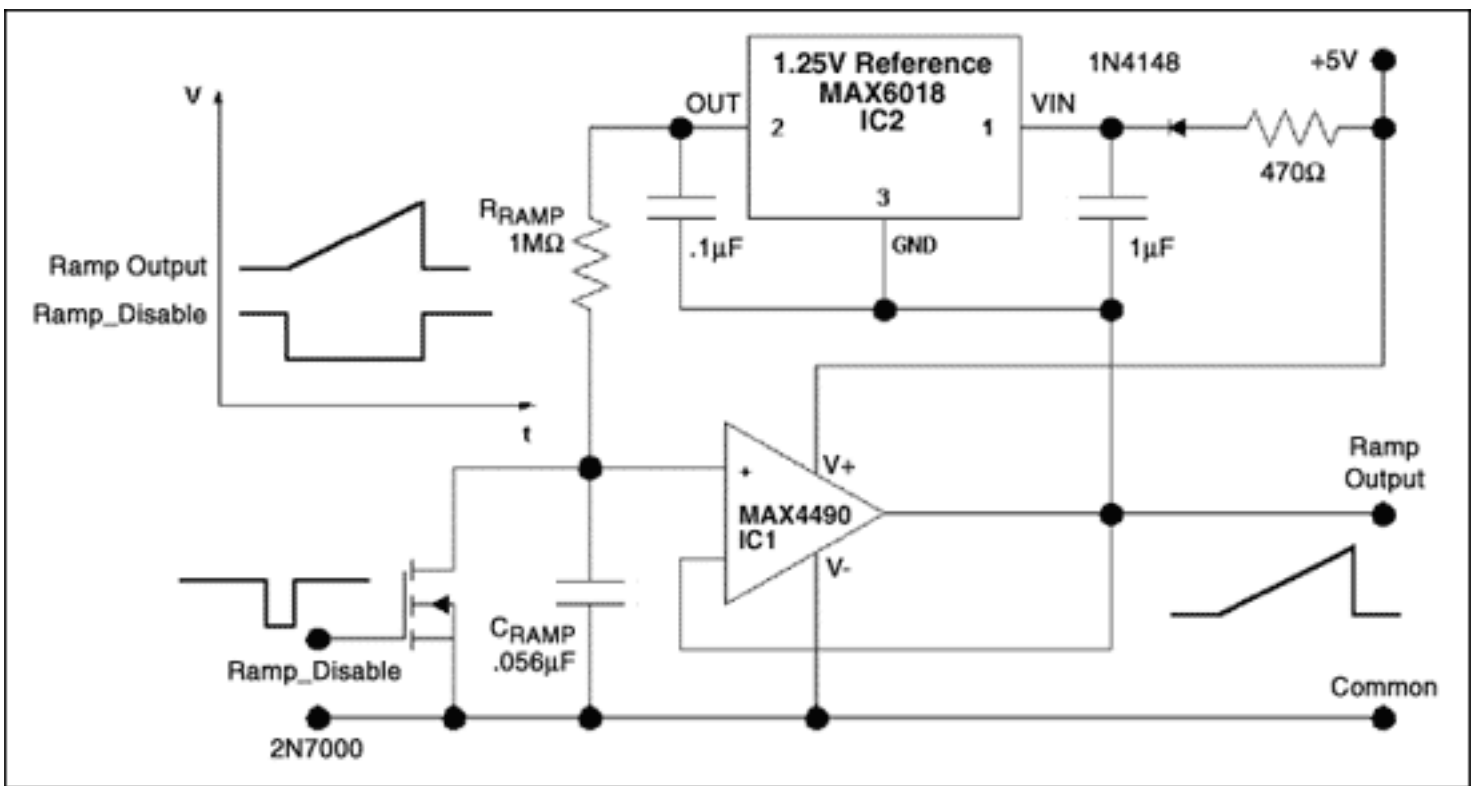

Figure 1. This precision ramp generator produces a 0 to 5V ramp while operating from a 5V supply.

The ramp is generated by a constant charging current into capacitor C_{RAMP} , which is connected between ground and the noninverting input of op amp IC1, configured as a voltage follower. The current through R_{RAMP} is the charging current, kept constant by forcing the voltage across R_{RAMP} to equal the reference voltage from IC1. One side of R_{RAMP} is connected to C_{RAMP} , and the other side to the reference output. In turn, the ground terminal of the reference IC connects to the op-amp output, which provides a low-impedance replica of the voltage across C_{RAMP} .

Thus, the op-amp output follows the C_{RAMP} voltage and drives the GND pin of the IC2 reference, keeping the voltage across R_{RAMP} equal to V_{REF} . A $1\mu F$ capacitor from the op-amp output bootstraps IC1's supply-voltage input, driving it above the nominal level yet keeping it within that device's operating range, and thereby allowing the op-amp output to reach its own supply-rail voltage.

A MOSFET switch across the ramp capacitor returns the ramp output to 0V when RAMP_DISABLE goes high, allowing the ramp to develop when RAMP_DISABLE is low. A scope shot of the ramp (Figure 2) shows the excursion limits for a supply voltage of 5.00V. The ramp slope is:

$$\frac{dV}{dt} = \frac{V_{REF}}{C_{RAMP} \times R_{RAMP}}$$

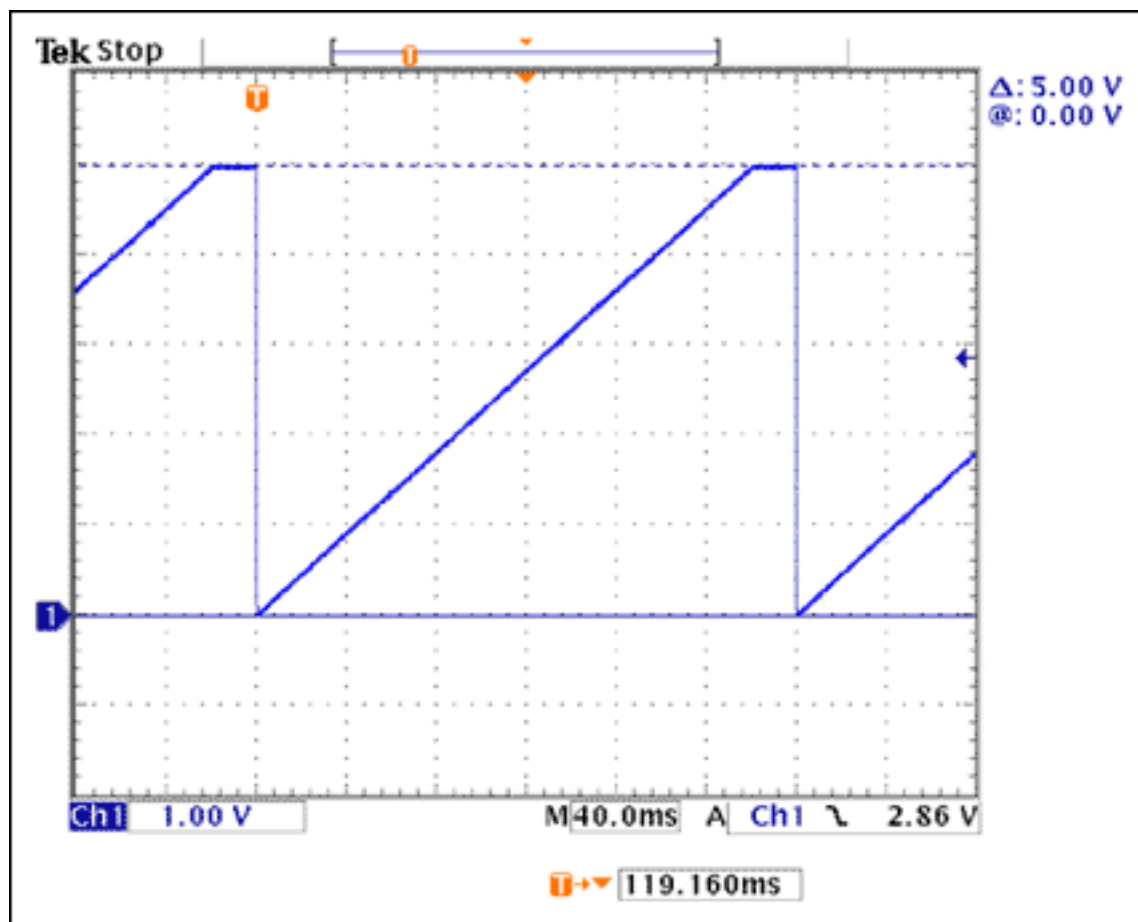

Figure 2. Ramp output for the circuit in Figure 1, operating from a 5V supply.

For a precise linear ramp, C_{RAMP} should be a high-quality capacitor with low leakage current and a low-voltage coefficient. The op amp must be capable of rail-to-rail input and output operation, and the 1.25V reference IC should have a low-quiescent supply current.

A similar article appeared in the May 2005 issue of *Electronic Design*.

Application Note 3655: www.maxim-ic.com/an3655

More Information

For technical support: www.maxim-ic.com/support

For samples: www.maxim-ic.com/samples

Other questions and comments: www.maxim-ic.com/contact

Automatic Updates

Would you like to be automatically notified when new application notes are published in your areas of interest?
[Sign up for EE-Mail™.](#)

Related Parts

MAX4490: [QuickView](#) -- [Full \(PDF\) Data Sheet](#) -- [Free Samples](#)

MAX6018: [QuickView](#) -- [Full \(PDF\) Data Sheet](#) -- [Free Samples](#)

AN3655, AN 3655, APP3655, Appnote3655, Appnote 3655

Copyright © by Maxim Integrated Products

Additional legal notices: www.maxim-ic.com/legal