

APPLICATION NOTE 3641

Migrating to the MAX6642 from Other Thermal Diode Temperature Sensors

The MAX6642 is a high-performance, low-cost, remote/local temperature sensor. When using the MAX6642 to replace an older temperature sensor, such as the MAX1617 or the MAX6657, the following guidelines should aid in the transition.

Layout Changes

Most thermal diode temperature sensors, including the MAX1617 and the MAX6654, have two connections to the diode: DXP and DXN. DXP connects to the thermal diode's anode and sources the diode bias current. DXN sinks the bias current and biases the cathode to about 0.7V.

The basic connection scheme is shown in **Figure 1**. The target IC can be a CPU, FPGA, or ASIC that has a diode-connected transistor for sensing die temperature.

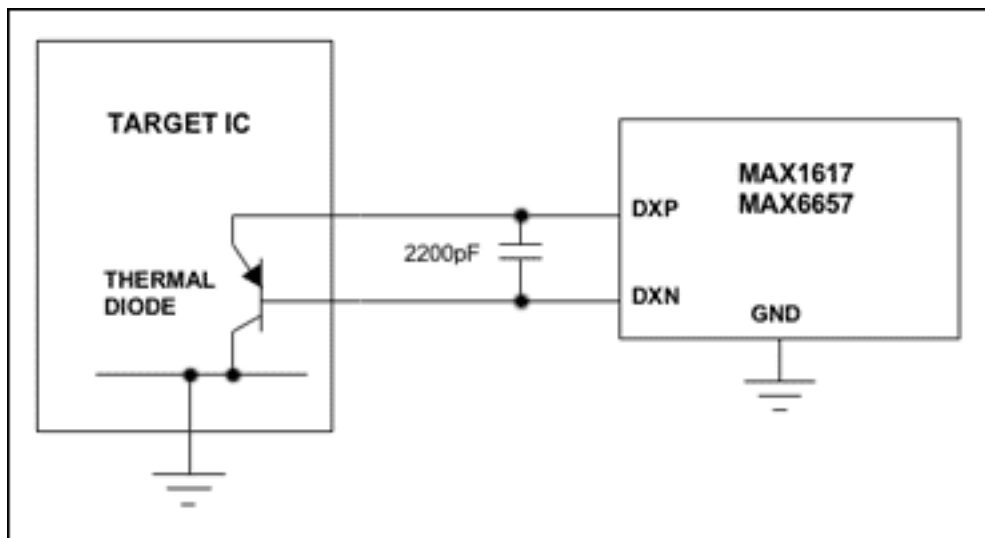

Figure 1. Connecting the MAX1617 or MAX6657 to a thermal diode.

The MAX6642 has just a DXP connection to the thermal diode's anode. There is no DXN; instead the cathode connects directly to ground. This changes the board layout somewhat as shown in **Figure 2**. Note that, because GND serves as both the power-supply ground and the cathode connection, the cathode of the thermal diode should be connected to ground only at the MAX6642 as shown in Figure 2. There should be no other connections to the ground trace between the thermal diode and the MAX6642, because small voltage drops due to ground currents through the trace will affect the accuracy of the temperature readings.

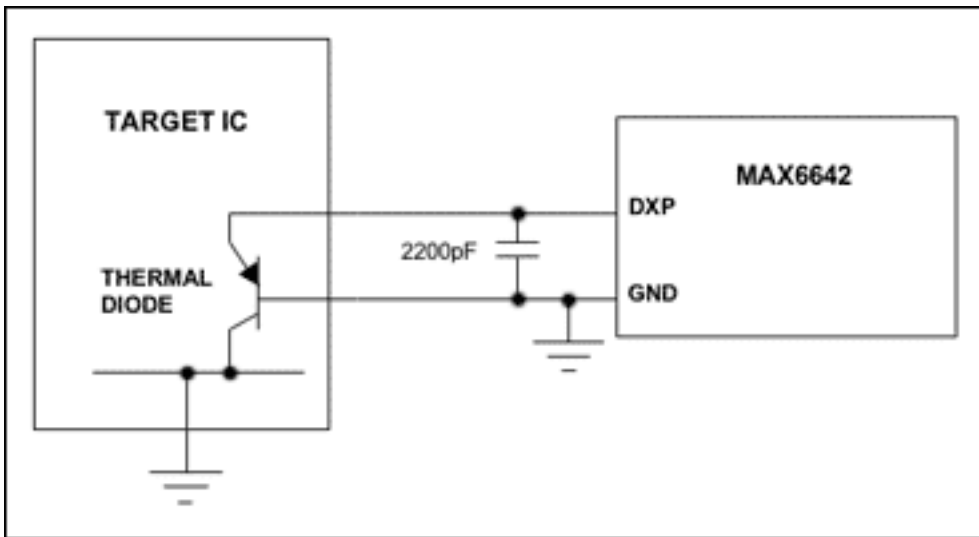

Figure 2. Connecting the MAX6642 to an external thermal diode.

Register Changes

The MAX6642 has a simpler register set than those of the MAX1617, MAX6654, and many other remote temperature sensors, as can be seen by consulting the product data sheets. However, as the MAX1617 is representative of most digital temperature sensors, the following brief overview of the differences between the MAX6642 and the MAX1617 provides a good example of such typical differences.

Local and Remote Temperature Registers

These registers are found at the same addresses in the MAX6642 and MAX1617. For temperatures from 0°C to +127°C, the MAX6642's temperature data format is the same as that of other sensors. However, unlike the MAX1617, which measures negative temperatures and stores the data in two's complement format, the MAX6642 uses the MSB to allow measurement of temperatures up to +150°C but does not measure negative temperatures.

Configuration Register

The MAX1617's Configuration register contains only a Mask bit and a Stop/Run bit. The MAX6642 has these bits and two more: External Only, which disables the internal (local) temperature sensor; and Fault Queue, which requires two consecutive temperature faults to be detected before asserting the ALERT# output.

THIGH and TLOW

The MAX1617 allows ALERTs to be asserted when the measured temperature either exceeds the THIGH limit, or falls below the TLOW limit. The MAX6642 has only high limits.

Conversion Rate

The MAX1617 has a Conversion Rate register that allows the temperature conversion rate to be set to one of several values. This register is not available on the MAX6642—there is just one fixed conversion rate.

Extended Temperature Registers

The MAX1617 has a temperature resolution of 1°C. The MAX6642 has a resolution of 0.25°C. The LSBs of the measured remote and local temperatures are available in the MAX6642's Extended Temperature registers.

Conclusion

As the preceding guidelines illustrate, the MAX6642 can replace industry-standard temperature sensors by making a few simple layout and software changes. Refer to the data sheet for detailed information on using the [MAX6642](#).

Application Note 3641: <http://www.maxim-ic.com/an3641>

More Information

For technical questions and support: <http://www.maxim-ic.com/support>

For samples: <http://www.maxim-ic.com/samples>

Other questions and comments: <http://www.maxim-ic.com/contact>

Related Parts

MAX1617: [QuickView](#) -- [Full \(PDF\) Data Sheet](#) -- [Free Samples](#)

MAX6642: [QuickView](#) -- [Full \(PDF\) Data Sheet](#) -- [Free Samples](#)

MAX6654: [QuickView](#) -- [Full \(PDF\) Data Sheet](#) -- [Free Samples](#)

AN3641, AN 3641, APP3641, Appnote3641, Appnote 3641

Copyright © 2005 by Maxim Integrated Products

Additional legal notices: <http://www.maxim-ic.com/legal>